

تهران سعادت آباد، بالاتر از میدان بهرود  
خ مهرباد عابدی . انتهای خیابان فاتحان  
مجتمع‌های علوم پزشکی . برج C۲

۳ - ۲۲۱۴۶۰۰۱

۲۲۳۸۳۱۷۹

[info@imensazehvazin.com](mailto:info@imensazehvazin.com)

[imensazehvazin.com](http://imensazehvazin.com)

[isvkala.com](http://isvkala.com)



# NFPA<sup>®</sup>

# 11

---

Standard for  
Low-, Medium-, and  
High-Expansion Foam

---

## 2021



## IMPORTANT NOTICES AND DISCLAIMERS CONCERNING NFPA® STANDARDS

NFPA® codes, standards, recommended practices, and guides (“NFPA Standards”), of which the document contained herein is one, are developed through a consensus standards development process approved by the American National Standards Institute. This process brings together volunteers representing varied viewpoints and interests to achieve consensus on fire and other safety issues. While the NFPA administers the process and establishes rules to promote fairness in the development of consensus, it does not independently test, evaluate, or verify the accuracy of any information or the soundness of any judgments contained in NFPA Standards.

The NFPA disclaims liability for any personal injury, property, or other damages of any nature whatsoever, whether special, indirect, consequential or compensatory, directly or indirectly resulting from the publication, use of, or reliance on NFPA Standards. The NFPA also makes no guaranty or warranty as to the accuracy or completeness of any information published herein.

In issuing and making NFPA Standards available, the NFPA is not undertaking to render professional or other services for or on behalf of any person or entity. Nor is the NFPA undertaking to perform any duty owed by any person or entity to someone else. Anyone using this document should rely on his or her own independent judgment or, as appropriate, seek the advice of a competent professional in determining the exercise of reasonable care in any given circumstances.

The NFPA has no power, nor does it undertake, to police or enforce compliance with the contents of NFPA Standards. Nor does the NFPA list, certify, test, or inspect products, designs, or installations for compliance with this document. Any certification or other statement of compliance with the requirements of this document shall not be attributable to the NFPA and is solely the responsibility of the certifier or maker of the statement.



### **ALERT: THIS STANDARD HAS BEEN MODIFIED BY A TIA OR ERRATA**

Users of NFPA codes, standards, recommended practices, and guides (“NFPA Standards”) should be aware that NFPA Standards may be amended from time to time through the issuance of a Tentative Interim Amendment (TIA) or corrected by Errata. An official NFPA Standard at any point in time consists of the current edition of the document together with any TIAs and Errata then in effect.

To determine whether an NFPA Standard has been amended through the issuance of TIAs or corrected by Errata, go to [www.nfpa.org/docinfo](http://www.nfpa.org/docinfo) to choose from the list of NFPA Standards or use the search feature to select the NFPA Standard number (e.g., NFPA 13). The document information page provides up-to-date document-specific information as well as postings of all existing TIAs and Errata. It also includes the option to register for an “Alert” feature to receive an automatic email notification when new updates and other information are posted regarding the document.

## **ADDITIONAL IMPORTANT NOTICES AND DISCLAIMERS CONCERNING NFPA® STANDARDS**

### **Updating of NFPA Standards**

Users of NFPA codes, standards, recommended practices, and guides (“NFPA Standards”) should be aware that these documents may be superseded at any time by the issuance of a new edition, may be amended with the issuance of Tentative Interim Amendments (TIAs), or be corrected by Errata. It is intended that through regular revisions and amendments, participants in the NFPA standards development process consider the then-current and available information on incidents, materials, technologies, innovations, and methods as these develop over time and that NFPA Standards reflect this consideration. Therefore, any previous edition of this document no longer represents the current NFPA Standard on the subject matter addressed. NFPA encourages the use of the most current edition of any NFPA Standard [as it may be amended by TIA(s) or Errata] to take advantage of current experience and understanding. An official NFPA Standard at any point in time consists of the current edition of the document, including any issued TIAs and Errata then in effect.

To determine whether an NFPA Standard has been amended through the issuance of TIAs or corrected by Errata, visit the “Codes & Standards” section at [www.nfpa.org](http://www.nfpa.org).

### **Interpretations of NFPA Standards**

A statement, written or oral, that is not processed in accordance with Section 6 of the Regulations Governing the Development of NFPA Standards shall not be considered the official position of NFPA or any of its Committees and shall not be considered to be, nor be relied upon as, a Formal Interpretation.

### **Patents**

The NFPA does not take any position with respect to the validity of any patent rights referenced in, related to, or asserted in connection with an NFPA Standard. The users of NFPA Standards bear the sole responsibility for determining the validity of any such patent rights, as well as the risk of infringement of such rights, and the NFPA disclaims liability for the infringement of any patent resulting from the use of or reliance on NFPA Standards.

NFPA adheres to the policy of the American National Standards Institute (ANSI) regarding the inclusion of patents in American National Standards (“the ANSI Patent Policy”), and hereby gives the following notice pursuant to that policy:

NOTICE: The user’s attention is called to the possibility that compliance with an NFPA Standard may require use of an invention covered by patent rights. NFPA takes no position as to the validity of any such patent rights or as to whether such patent rights constitute or include essential patent claims under the ANSI Patent Policy. If, in connection with the ANSI Patent Policy, a patent holder has filed a statement of willingness to grant licenses under these rights on reasonable and nondiscriminatory terms and conditions to applicants desiring to obtain such a license, copies of such filed statements can be obtained, on request, from NFPA. For further information, contact the NFPA at the address listed below.

### **Law and Regulations**

Users of NFPA Standards should consult applicable federal, state, and local laws and regulations. NFPA does not, by the publication of its codes, standards, recommended practices, and guides, intend to urge action that is not in compliance with applicable laws, and these documents may not be construed as doing so.

### **Copyrights**

NFPA Standards are copyrighted. They are made available for a wide variety of both public and private uses. These include both use, by reference, in laws and regulations, and use in private self-regulation, standardization, and the promotion of safe practices and methods. By making these documents available for use and adoption by public authorities and private users, the NFPA does not waive any rights in copyright to these documents.

Use of NFPA Standards for regulatory purposes should be accomplished through adoption by reference. The term “adoption by reference” means the citing of title, edition, and publishing information only. Any deletions, additions, and changes desired by the adopting authority should be noted separately in the adopting instrument. In order to assist NFPA in following the uses made of its documents, adopting authorities are requested to notify the NFPA (Attention: Secretary, Standards Council) in writing of such use. For technical assistance and questions concerning adoption of NFPA Standards, contact NFPA at the address below.

### **For Further Information**

All questions or other communications relating to NFPA Standards and all requests for information on NFPA procedures governing its codes and standards development process, including information on the procedures for requesting Formal Interpretations, for proposing Tentative Interim Amendments, and for proposing revisions to NFPA standards during regular revision cycles, should be sent to NFPA headquarters, addressed to the attention of the Secretary, Standards Council, NFPA, 1 Batterymarch Park, P.O. Box 9101, Quincy, MA 02269-9101; email: [stds\\_admin@nfpa.org](mailto:stds_admin@nfpa.org).

For more information about NFPA, visit the NFPA website at [www.nfpa.org](http://www.nfpa.org). All NFPA codes and standards can be viewed at no cost at [www.nfpa.org/docinfo](http://www.nfpa.org/docinfo).

Copyright © 2020 National Fire Protection Association®. All Rights Reserved.

## NFPA® 11

### Standard for

## Low-, Medium-, and High-Expansion Foam

### 2021 Edition

This edition of NFPA 11, *Standard for Low-, Medium-, and High-Expansion Foam*, was prepared by the Technical Committee on Foam. It was issued by the Standards Council on November 2, 2020, with an effective date of November 22, 2020, and supersedes all previous editions.

This document has been amended by one or more Tentative Interim Amendments (TIAs) and/or Errata. See "Codes & Standards" at [www.nfpa.org](http://www.nfpa.org) for more information.

This edition of NFPA 11 was approved as an American National Standard on November 22, 2020.

### Origin and Development of NFPA 11

NFPA committee activity in this field dates from 1921, when the Committee on Manufacturing Risks and Special Hazards prepared standards on foam as a section of the general *Standard on Protection of Fire Hazards, Incident to the Use of Volatiles in Manufacturing Processes*. Subsequently the standards were successively under the jurisdiction of the Committee on Manufacturing Hazards and the Committee on Special Extinguishing Systems, prior to the present committee organization. The present text supersedes the prior editions adopted in 1922, 1926, 1931, 1936, 1942, 1950, 1954, 1959, 1960, 1963, 1969, 1970, 1972, 1973, 1974, 1975, 1976, and 1978. It also supersedes the 1977 edition of NFPA 11B.

The 1983 edition was completely rewritten to include all the material formerly contained in NFPA 11B, *Standard on Synthetic and Combined Agent Systems*. The standard was revised in 1988 and again in 1994 to state the requirements more clearly and to separate mandatory requirements from advisory text.

The standard was revised for the 1998 edition to include requirements for foam systems for marine applications and to provide guidance relating to the environmental impact of foam system discharges.

The 2002 edition was revised to address mixing of foam concentrates and to clarify requirements related to foam concentrate pumps. Requirements for medium- and high-expansion foam systems were included.

The 2005 edition was reorganized to provide the requirements for low-, medium-, and high-expansion foam, to better incorporate the requirements of NFPA 11A.

The 2010 edition added a new chapter to address compressed air foam systems. Unenforceable terms were removed to comply with the *Manual of Style for NFPA Technical Committee Documents*.

For the 2016 edition, the committee addressed several areas of concern. The piping requirements were reorganized and clarified, issues regarding acceptance criteria for annual foam concentrate testing were addressed, environmentally friendly methods of testing foam proportioners were recognized, and seal-only protection was permitted for composite roofs that meet specific criteria.

The 2021 edition contains multiple revisions to address the use of synthetic fluorine free foam (SFFF), including a new definition for SFFF. New definitions and explanatory annex material have been provided for cone roofs and external floating roofs. In Chapter 4, requirements that listed the types of foams permitted to be used on hydrocarbon fuels have been deleted, as the standard already requires foams to be listed for the flammable or combustible liquid they are protecting. Metric conversions throughout the standard have been updated as necessary to provide more usable numbers for metric users.

The 2021 edition also includes multiple new chapters and annexes. The requirements of NFPA 16, *Standard for the Installation of Foam-Water Sprinkler and Foam-Water Spray Systems*, have been

consolidated into a new Chapter 6. A new Chapter 13 replaces the existing maintenance requirements with more comprehensive requirements for inspection, testing, and maintenance, including minimum requirements and frequency. A new Annex H provides summaries of current research and testing for the use of synthetic fluorine free foam (SFFF). A new Annex I outlines a testing protocol for a rim seal fire test for nonmetallic floating roof structures.

### Technical Committee on Foam

**Joan M. Leedy, Chair**  
Dyne Technologies, MN [IM]

**Terry L. Victor, Secretary**  
Johnson Controls, MD [M]

**Gerard G. Back**, JENSEN HUGHES, MD [SE]  
**Tracey D. Bellamy**, Telgian Corporation, GA [SE]  
**Gene E. Benzenberg**, Alison Control Inc., NJ [M]  
**Judy Biddle**, US Department of the Air Force, FL [E]  
**Richard A. Coppola**, Oliver Fire Protection & Security, PA [M]  
Rep. National Fire Sprinkler Association  
**Steven Fox**, Sprinklerfitters U.A. Local 483, CA [L]  
Rep. United Assn. of Journeymen & Apprentices of the  
Plumbing & Pipe Fitting Industry  
**Robbie Gordon**, ExxonMobil Corporation, TX [U]  
Rep. American Petroleum Institute  
**Martin Hawkes**, Hawkes Fire Ltd, United Kingdom [IM]  
**Scott E. Herreth**, Dooley Tackaberry, Inc., TX [IM]  
Rep. National Association of Fire Equipment Distributors  
**Adam Hofman**, Valero, TX [U]  
**William E. Janz**, Global Asset Protection Services, LLC, IL [I]  
**Bill Johns, P.E.**, Los Angeles City Fire Department, CA [E]  
**Robert Kasiski**, FM Global, RI [I]

**Jeffrey S. Kidd**, The Hiller Companies, MA [M]  
Rep. Fire Suppression Systems Association  
**Bernard W. Leong**, Chevron Energy Technology Company, TX [U]  
**Randy R. Nelson, P.E.**, VFS Fire and Security Services, CA [IM]  
Rep. American Fire Sprinkler Association  
**Austin G. Prather**, Hayden and Company, TX [M]  
**Fay Purvis**, Vector Fire Technology, Inc., PA [SE]  
**Raymond Quenneville**, FireFlex Systems, Inc., Canada [M]  
**Niall Ramsden**, LASTFIRE, United Kingdom [SE]  
**Steven J. Scandaliato**, SDG, LLC, TX [SE]  
**Blake M. Shugarman**, UL LLC, IL [RT]  
**Mark Siem**, The Solberg Company, WI [M]  
**Robert Thilthorpe**, Fire Industry Association, Great Britain [U]  
**Kevin D. Westwood**, BP International, United Kingdom [U]  
**Martin H. Workman**, The Viking Corporation, MI [M]  
**John P. Woycheese**, Saudi Aramco, Saudi Arabia [U]

#### Alternates

**Elliott A Berg**, Vector Fire Technology, AZ [SE]  
(Alt. to Fay Purvis)  
**Tim D. Blackford**, Chevron Energy Technology Company, TX [U]  
(Alt. to Bernard W. Leong)  
**Christopher H. Born**, Clark Nexsen, Inc., VA [IM]  
(Alt. to Randy R. Nelson, P.E.)  
**Michael Cedrone**, FM Global, RI [I]  
(Alt. to Robert Kasiski)  
**Antony Chung**, Dominion Energy, VA [U]  
(Voting Alt.)  
**Craig W. Cook**, Johnson Controls, WI [M]  
(Alt. to Terry L. Victor)  
**Shawn Feenstra**, The Viking Corporation, MI [M]  
(Alt. to Martin H. Workman)  
**Edward M. Hawthorne**, DFW Dynamics, TX [U]  
(Alt. to Robbie Gordon)  
**Chad Duffy**, NFPA Staff Liaison

**Paul Hubrich**, Global Asset Protection Services, LLC, WI [I]  
(Alt. to William E. Janz)  
**Jerauld R. Kirkpatrick**, UL LLC, IL [RT]  
(Alt. to Blake M. Shugarman)  
**Doug Lackey**, Ahern Fire Protection, WI [M]  
(Alt. to Jeffrey S. Kidd)  
**Grant Lobdell**, Dyne Technologies LLC, MN [IM]  
(Alt. to Joan M. Leedy)  
**Joseph M. Pada**, Amerex Corporation, WI [M]  
(Alt. to Mark Siem)  
**Alexander Popov**, JENSEN HUGHES, IL [SE]  
(Alt. to Gerard G. Back)  
**Sean Ramsey**, US Coast Guard, DC [E]  
(Voting Alt.)  
**Jonathan Roger**, Fireflex Systems, Canada [M]  
(Alt. to Raymond Quenneville)

*This list represents the membership at the time the Committee was balloted on the final text of this edition. Since that time, changes in the membership may have occurred. A key to classifications is found at the back of the document.*

NOTE: Membership on a committee shall not in and of itself constitute an endorsement of the Association or any document developed by the committee on which the member serves.

**Committee Scope:** This Committee shall have primary responsibility for documents on the installation, maintenance, and use of foam systems for fire protection, including foam hose streams.

## Contents

<b>Chapter 1 Administration</b> .....	11- 6	7.13 Local Application Systems. ....	11- 40
1.1 Scope. ....	11- 6	7.14 Foam Applications for Liquefied Natural Gas (LNG). ....	11- 41
1.2 Purpose. ....	11- 6	7.15 Portable Foam-Generating Devices. ....	11- 41
1.3 Application. ....	11- 6		
1.4 Retroactivity. ....	11- 6		
1.5 Equivalency. ....	11- 6		
1.6 Units and Formulas. ....	11- 6		
<b>Chapter 2 Referenced Publications</b> .....	11- 6	<b>Chapter 8 Compressed Air Foam Systems</b> .....	11- 42
2.1 General. ....	11- 6	8.1 General. ....	11- 42
2.2 NFPA Publications. ....	11- 6	8.2 Water Supplies. ....	11- 42
2.3 Other Publications. ....	11- 7	8.3 Foam Concentrate. ....	11- 42
2.4 References for Extracts in Mandatory Sections. ....	11- 8	8.4 Air or Nitrogen Supply. ....	11- 42
		8.5 Compressed Air Foam-Generating Method. ....	11- 43
		8.6 Distribution Systems. ....	11- 43
		8.7 Compressed Air Foam Discharge Devices. ....	11- 43
		8.8 Operation and Control of Systems. ....	11- 43
		8.9 System Types. ....	11- 43
		8.10 Limitations. ....	11- 43
		8.11 System Design. ....	11- 43
		8.12 Installation of Piping and Fittings. ....	11- 43
		8.13 Installation of Automatic Detection. ....	11- 43
		8.14 CAFS Discharge Device Choice and Location. ....	11- 43
		8.15 Discharge Density. ....	11- 43
		8.16 Discharge Duration. ....	11- 43
		8.17 System Flow Calculation. ....	11- 43
		8.18 Plans and Specifications. ....	11- 44
		8.19 Testing and Acceptance. ....	11- 44
		8.20 Maintenance. ....	11- 44
<b>Chapter 3 Definitions</b> .....	11- 8	<b>Chapter 9 Specifications and Plans</b> .....	11- 44
3.1 General. ....	11- 8	9.1 Approval of Plans. ....	11- 44
3.2 NFPA Official Definitions. ....	11- 8	9.2 Specifications. ....	11- 44
3.3 General Definitions. ....	11- 9	9.3 Plans. ....	11- 44
<b>Chapter 4 System Components and System Types</b> .....	11- 11	<b>Chapter 10 Installation Requirements</b> .....	11- 45
4.1 General. ....	11- 11	10.1 Foam Concentrate Pumps. ....	11- 45
4.2 Water Supplies. ....	11- 12	10.2 Flushing. ....	11- 45
4.3 Foam Concentrates. ....	11- 12	10.3 Power Supply. ....	11- 45
4.4 Concentrate Compatibility. ....	11- 14	10.4 Low-Expansion System Piping. ....	11- 45
4.5 Foam Proportioning. ....	11- 14	10.5 Valves in Low-Expansion Systems. ....	11- 46
4.6 Foam Concentrate Pumps. ....	11- 14	10.6 Hangers, Supports, and Protection for Pipework. ....	11- 46
4.7 Piping. ....	11- 15	10.7 Hose Requirements. ....	11- 46
4.8 System Types. ....	11- 16	10.8 Test Connections. ....	11- 46
4.9 Operation and Control of Systems. ....	11- 16		
<b>Chapter 5 Low-Expansion Foam Tank, Fueling, and Spill Area Systems</b> .....	11- 17	<b>Chapter 11 Low-Expansion Foam Systems for Marine Applications</b> .....	11- 46
5.1 Types of Hazards. ....	11- 17	11.1 General. ....	11- 46
5.2 Outdoor Fixed-Roof (Cone) Tanks. ....	11- 17	11.2 Fixed Low-Expansion Foam Systems for Machinery Spaces. ....	11- 47
5.3 Outdoor Open-Top Floating Roof Tanks. ....	11- 21	11.3 Fixed Low-Expansion Foam Systems on Deck for Petroleum and Chemical Tankers. ....	11- 47
5.4 Outdoor Covered (Internal) Floating Roof Tanks. ....	11- 25	11.4 Foam Outlet Devices. ....	11- 48
5.5 Indoor Hazards. ....	11- 27	11.5 Monitors. ....	11- 48
5.6 Loading Racks. ....	11- 27	11.6 Hand Hoselines. ....	11- 48
5.7 Diked Areas — Outdoor. ....	11- 28	11.7 Hydraulic Calculations. ....	11- 49
5.8 Nondiked Spill Areas. ....	11- 29	11.8 Isolation Valves. ....	11- 49
5.9 Supplementary Protection. ....	11- 29	11.9 Hangers, Supports, and Protection of Pipework. ....	11- 49
<b>Chapter 6 Low-Expansion Foam Sprinkler and Spray Systems</b> .....	11- 29	11.10 Testing and Inspection. ....	11- 49
6.1 Administration. ....	11- 29	11.11 Foam System Concentrate Storage. ....	11- 49
6.2 General System Requirements. ....	11- 30	11.12 Supply Arrangements. ....	11- 49
6.3 Working Plans. ....	11- 30	11.13 Piping Materials. ....	11- 50
6.4 System Components. ....	11- 30		
6.5 System Design and Installation. ....	11- 32	<b>Chapter 12 Acceptance Testing</b> .....	11- 50
6.6 Acceptance Tests. ....	11- 35	12.1 Inspection and Visual Examination. ....	11- 50
6.7 Inspection, Testing, and Maintenance. ....	11- 36	12.2 Flushing after Installation. ....	11- 50
		12.3 Acceptance Tests. ....	11- 50
		12.4 Pressure Tests. ....	11- 50
		12.5 Operating Tests. ....	11- 50
<b>Chapter 7 Medium- and High-Expansion Systems</b> .....	11- 36		
7.1 General Information and Requirements. ....	11- 36		
7.2 Use and Limitations. ....	11- 36		
7.3 Hazards Protected. ....	11- 36		
7.4 Types of Systems. ....	11- 36		
7.5 Systems Protecting One or More Hazards. ....	11- 36		
7.6 Occupant Safety and Rescue Operations. ....	11- 36		
7.7 Operation and Control of Systems. ....	11- 37		
7.8 Foam Concentrate. ....	11- 37		
7.9 Air Supply. ....	11- 38		
7.10 Foam-Generating Apparatus Location. ....	11- 38		
7.11 Distribution Systems. ....	11- 38		
7.12 Total Flooding Systems General Information. ....	11- 38		



12.6	Discharge Tests .....	11- 51	<b>Annex D</b>	<b>Tests for Foam Systems .....</b>	11- 115
12.7	Approval of Low-, Medium-, and High-Expansion Foam Systems .....	11- 51	<b>Annex E</b>	<b>Foam Health, Safety, and Environmental Issues .....</b>	11- 129
12.8	System Restoration .....	11- 51	<b>Annex F</b>	<b>Test Method for Marine Firefighting Foam Concentrates Protecting Hydrocarbon Hazards .....</b>	11- 132
12.9	Acceptance Tests of Foam-Water Deluge and Spray Systems .....	11- 51	<b>Annex G</b>	<b>Foam Concentrate Quality .....</b>	11- 134
<b>Chapter 13</b>	<b>Inspection, Testing, and Maintenance .....</b>	11- 55	<b>Annex H</b>	<b>Synthetic Fluorine-Free Foam (SFFF) Research Testing Summary .....</b>	11- 137
13.1	General .....	11- 55	<b>Annex I</b>	<b>Rim Seal Fire Test Protocol .....</b>	11- 148
13.2	Low-, Medium-, and High-Expansion Foam Systems .....	11- 57	<b>Annex J</b>	<b>Informational References .....</b>	11- 158
13.3	Foam-Water Sprinkler Systems .....	11- 57	<b>Index</b>	<b>.....</b>	11- 160
<b>Annex A</b>	<b>Explanatory Material .....</b>	11- 62			
<b>Annex B</b>	<b>Storage Tank Protection Summary .....</b>	11- 112			
<b>Annex C</b>	<b>Medium- and High-Expansion Foam .....</b>	11- 115			

## NFPA 11

## Standard for

## Low-, Medium-, and High-Expansion Foam

2021 Edition

**IMPORTANT NOTE:** This NFPA document is made available for use subject to important notices and legal disclaimers. These notices and disclaimers appear in all publications containing this document and may be found under the heading "Important Notices and Disclaimers Concerning NFPA Standards." They can also be viewed at [www.nfpa.org/disclaimers](http://www.nfpa.org/disclaimers) or obtained on request from NFPA.

**UPDATES, ALERTS, AND FUTURE EDITIONS:** New editions of NFPA codes, standards, recommended practices, and guides (i.e., NFPA Standards) are released on scheduled revision cycles. This edition may be superseded by a later one, or it may be amended outside of its scheduled revision cycle through the issuance of Tentative Interim Amendments (TIAs). An official NFPA Standard at any point in time consists of the current edition of the document, together with all TIAs and Errata in effect. To verify that this document is the current edition or to determine if it has been amended by TIAs or Errata, please consult the National Fire Codes® Subscription Service or the "List of NFPA Codes & Standards" at [www.nfpa.org/docinfo](http://www.nfpa.org/docinfo). In addition to TIAs and Errata, the document information pages also include the option to sign up for alerts for individual documents and to be involved in the development of the next edition.

**NOTICE:** An asterisk (\*) following the number or letter designating a paragraph indicates that explanatory material on the paragraph can be found in Annex A.

A reference in brackets [ ] following a section or paragraph indicates material that has been extracted from another NFPA document. Extracted text may be edited for consistency and style and may include the revision of internal paragraph references and other references as appropriate. Requests for interpretations or revisions of extracted text shall be sent to the technical committee responsible for the source document.

Information on referenced and extracted publications can be found in Chapter 2 and Annex J.

## Chapter 1 Administration

## 1.1\* Scope.

**1.1.1** This standard covers the design, installation, operation, testing, and maintenance of low-, medium-, and high-expansion and compressed air foam systems for fire protection.

**1.1.2\*** It is not the intent of this standard to specify where foam protection is required.

## 1.2 Purpose.

**1.2.1** This standard is intended for the use and guidance of those responsible for designing, installing, testing, inspecting, approving, listing, operating, or maintaining fixed, semifixed, or portable low-, medium-, and high-expansion and compressed air foam fire-extinguishing systems for interior or exterior hazards.

**1.2.2** Nothing in this standard is intended to restrict new technologies or alternative arrangements, provided the level of safety prescribed by the standard is not lowered.

**1.2.3** Low-, medium-, and high- expansion foam and compressed air foam systems are intended to provide property protection and not life safety.

**1.3 Application.** This standard is not applicable to the following types of systems:

- (1) Chemical foams and systems (considered obsolete)
- (2) Combined agent systems
- (3) Mobile foam apparatus (See NFPA 1901.)
- (4) Class A foam and systems (See NFPA 1150.)

**1.4 Retroactivity.** The provisions of this standard reflect a consensus of what is necessary to provide an acceptable degree of protection from the hazards addressed in this standard at the time the standard was issued.

**1.4.1** Unless otherwise specified, the provisions of this standard shall not apply to facilities, equipment, structures, or installations that existed or were approved for construction or installation prior to the effective date of the standard. Where specified, the provisions of this standard shall be retroactive.

**1.4.2** In those cases where the authority having jurisdiction determines that the existing situation presents an unacceptable degree of risk, the authority having jurisdiction shall be permitted to apply retroactively any portions of this standard deemed appropriate.

**1.4.3** The retroactive requirements of this standard shall be permitted to be modified if their application clearly would be impractical in the judgment of the authority having jurisdiction, and only where it is clearly evident that a reasonable degree of safety is provided.

**1.5 Equivalency.** Nothing in this standard is intended to prevent the use of systems, methods, or devices of equivalent or superior quality, strength, fire resistance, effectiveness, durability, and safety over those prescribed by this standard.

**1.5.1** Technical documentation shall be submitted to the authority having jurisdiction to demonstrate equivalency.

**1.5.2** The system, method, or device shall be approved for the intended purpose by the authority having jurisdiction.

**1.6 Units and Formulas.** Metric units of measurement in this standard are in accordance with the modernized metric system known as the International System of Units (SI). The liter unit, which is not part of but is recognized by SI, is commonly used in international fire protection. Conversion factors for this unit are found in Table 1.6.

## Chapter 2 Referenced Publications

**2.1 General.** The documents or portions thereof listed in this chapter are referenced within this standard and shall be considered part of the requirements of this document.

**2.2 NFPA Publications.** National Fire Protection Association, 1 Batterymarch Park, Quincy, MA 02169-7471.

NFPA 13, *Standard for the Installation of Sprinkler Systems*, 2019 edition.

NFPA 14, *Standard for the Installation of Standpipe and Hose Systems*, 2019 edition.

NFPA 15, *Standard for Water Spray Fixed Systems for Fire Protection*, 2017 edition.

**Table 1.6 Conversion Factors**

	Name of Unit	Unit Symbol	Conversion Factor
Length	millimeter	mm	1 in. = 25 mm
	meter	m	1 ft = 0.3048 m
Area	square millimeters	mm <sup>2</sup>	1 in. <sup>2</sup> = 645.2 mm <sup>2</sup>
	square meter	m <sup>2</sup>	1 ft <sup>2</sup> = 0.0929 m <sup>2</sup>
Volume	milliliter	mL	1 fl oz = 29.57 mL
Fluid capacity	liter	l	1 fl oz = 0.02957 L
	liter	l	1 gal = 3.785 L
Flow	liter per minute	L/min	1 gpm = 3.7848 L/min
Pressure	bar	bar	1 psi = 0.0689 bar
Discharge Density	millimeter/minute	mm/min	1 gpm/ft <sup>2</sup> = 40.746 mm/min
	liter/minute/m <sup>2</sup>	(L/min)/m <sup>2</sup>	1 gpm/ft <sup>2</sup> = 40.746 (L/min)/m <sup>2</sup>
Weight	kilogram	kg	1 lb = 0.4536 kg
Temperature	Fahrenheit	°F	°F = 9/5 x °C + 32
	Celsius	°C	°C = 5/9(°F - 32)
Velocity	meters per second	mps	1 fps = 0.3048 mps
Gauge (sheet steel)	millimeter	mm	10 gauge = 3.4 mm
			12 gauge = 2.8 mm
			14 gauge = 1.98 mm
			16 gauge = 1.57 mm
			22 gauge = 0.78 mm
		24 gauge = 0.63 mm	

Note: For additional conversions and information, see IEEE/ASTM SI10.

NFPA 16, *Standard for the Installation of Foam-Water Sprinkler and Foam-Water Spray Systems*, 2019 edition.

NFPA 20, *Standard for the Installation of Stationary Pumps for Fire Protection*, 2019 edition.

NFPA 22, *Standard for Water Tanks for Private Fire Protection*, 2018 edition.

NFPA 24, *Standard for the Installation of Private Fire Service Mains and Their Appurtenances*, 2019 edition.

NFPA 25, *Standard for the Inspection, Testing, and Maintenance of Water-Based Fire Protection Systems*, 2020 edition.

NFPA 30, *Flammable and Combustible Liquids Code*, 2021 edition.

NFPA 70<sup>®</sup>, *National Electrical Code<sup>®</sup>*, 2020 edition.

NFPA 72<sup>®</sup>, *National Fire Alarm and Signaling Code<sup>®</sup>*, 2019 edition.

NFPA 220, *Standard on Types of Building Construction*, 2021 edition.

NFPA 409, *Standard on Aircraft Hangars*, 2021 edition.

NFPA 1150, *Standard on Foam Chemicals for Fires in Class A Fuels*, 2017 edition.

NFPA 1901, *Standard for Automotive Fire Apparatus*, 2021 edition.

NFPA 1961, *Standard on Fire Hose*, 2020 edition.

NFPA 1963, *Standard for Fire Hose Connections*, 2019 edition.

**2.3 Other Publications.**

**2.3.1 API Publications.** American Petroleum Institute, 1220 L Street, N.W., Washington, DC 20005-4070.

API STD 607, *Fire Test for Quarter-turn Valves and Valves Equipped with Nonmetallic Seats*, 7th edition, 2016.

API STD 650, *Welded Tanks for Oil Storage*, 12th edition, 2013, addendum 3, 2018.

**2.3.2 ASME Publications.** American Society of Mechanical Engineers, Two Park Avenue, New York, NY 10016-5990.

ASME Boiler and Pressure Vessel Code, 2019.

ASME B1.20.1, *Standard for Pipe Threads, General Purpose (Inch)*, 2013.

ASME B16.1, *Gray Iron Pipe Flanges and Flanged Fittings Classes 25, 125, and 250*, 2015.

ASME B16.3, *Malleable Iron Threaded Fittings: Classes 150, and 300*, 2016.

ASME B16.4, *Gray Iron Threaded Fittings Classes 125, and 250*, 2016.

ASME B16.5, *Pipe Flanges and Flanged Fittings: NPS 1/2 Through 24 Metric/Inch Standard*, 2017.

ASME B16.9, *Factory-Made Wrought Buttwelding Fittings*, 2012.

ASME B16.11, *Forged Fittings, Socket-Welding and Threaded*, 2016, Errata, 2017.

ASME B16.15, *Cast Copper Alloy Threaded Fittings Classes 125, and 250*, 2013.

ASME B16.24, *Cast Copper Alloy Pipe Flanges, Flanged Fittings, and Valves Classes 150, 300, 600, 900, 1500, and 2500*, 2016.

ASME B16.25, *Buttwelding Ends*, 2017.

ASME B31.1, *Power Piping*, 2018.

**2.3.3 ASTM Publications.** ASTM International, 100 Barr Harbor Drive, P.O. Box C700, West Conshohocken, PA 19428-2959.

ASTM A53/A53M *Standard Specification for Pipe, Steel, Black and Hot-Dipped, Zinc-Coated, Welded and Seamless*, 2018.

ASTM A135/A135M, *Standard Specification for Electric Resistance-Welded Steel Pipe*, 2009, reapproved 2014.

ASTM A234/A234M, *Standard Specification for Piping Fittings of Wrought Carbon Steel and Alloy Steel for Moderate and High-Temperature Service*, 2018.

ASTM A312/A312M, *Standard Specification for Seamless, Welded, and Heavily Cold Worked Austenitic Stainless Steel Pipes*, 2018.

ASTM A795/A795M, *Standard Specification for Black and Hot-Dipped-, Zinc-Coated-, (Galvanized) Welded and Seamless Steel Pipe for Fire Protection Use*, 2013.

ASTM B43, *Standard Specification for Seamless Red Brass Pipe, Standard Sizes*, 2015.

ASTM B315, *Standard Specification for Seamless Copper Alloy Pipe and Tube*, 2012.

ASTM C582, *Standard Specification for Contact-Molded Reinforced Thermosetting Plastic (RTP) Laminates for Corrosion-Resistant Equipment*, 2009, reapproved 2016.

ASTM D323, *Standard Test Method for Vapor Pressure of Petroleum Products (Reid Method)*, 2015a.

ASTM D1331, *Standard Test Methods for Surface and Interfacial Tension of Solutions of Paints, Solvents, Solutions of Surface-Active Agents, and Related Materials*, 2014.

ASTM E84, *Standard Test Method for Surface Burning Characteristics of Building Materials*, 2019b.

IEEE/ASTM SI10, *American National Standard for the Use of the International System of Units: The Modern Metric System*, 2016.

**2.3.4 AWS Publications.** American Welding Society, 8669 NW 36 Street, #130, Miami, FL 33166-6672.

AWS B2.1/B2.1M, *Specification for Welding Procedure and Performance Qualification*, 2014.

**2.3.5 IEEE Publications.** IEEE, Three Park Avenue, 17th Floor, New York, NY 10016-5997.

IEEE 45, *Recommended Practice for Electric Installations on Shipboard*, 2002.

**2.3.6 IMO Publications.** International Maritime Organization, 4 Albert Embankment, London SE1 7SR, United Kingdom.

*Safety of Life at Sea*, SOLAS Regulations II-2/4.3 and 4.3.5.

**2.3.7 ISO Publications.** International Organization for Standardization, ISO Central Secretariat, BIBC II, Chemin de Blandonnet 8, CP 401, 1214 Vernier, Geneva, Switzerland.

ISO 7-1, *Pipe Threads Where Pressure-Tight Joints Are Made on the Threads — Part 1: Dimensions, Tolerances and Designation*, 1994, technical corrigendum 1, 2007.

**2.3.8 UL Publications.** Underwriters Laboratories Inc., 333 Pfingsten Road, Northbrook, IL 60062-2096.

UL 162, *Foam Equipment and Liquid Concentrates*, 2018.

**2.3.9 Other Publications.**

*Merriam-Webster's Collegiate Dictionary*, 11th edition, Merriam-Webster, Inc., Springfield, MA, 2003.

## 2.4 References for Extracts in Mandatory Sections.

NFPA 10, *Standard for Portable Fire Extinguishers*, 2018 edition.  
NFPA 13, *Standard for the Installation of Sprinkler Systems*, 2019 edition.

NFPA 25, *Standard for the Inspection, Testing, and Maintenance of Water-Based Fire Protection Systems*, 2020 edition.

NFPA 30, *Flammable and Combustible Liquids Code*, 2018 edition.

NFPA 820, *Standard for Fire Protection in Wastewater Treatment and Collection Facilities*, 2016 edition.

## Chapter 3 Definitions

**3.1 General.** The definitions contained in this chapter shall apply to the terms used in this standard. Where terms are not defined in this chapter or within another chapter, they shall be defined using their ordinarily accepted meanings within the context in which they are used. *Merriam-Webster's Collegiate Dictionary*, 11th edition, shall be the source for the ordinarily accepted meaning.

### 3.2 NFPA Official Definitions.

**3.2.1\* Approved.** Acceptable to the authority having jurisdiction.

**3.2.2\* Authority Having Jurisdiction (AHJ).** An organization, office, or individual responsible for enforcing the requirements of a code or standard, or for approving equipment, materials, an installation, or a procedure.

**3.2.3 Labeled.** Equipment or materials to which has been attached a label, symbol, or other identifying mark of an organization that is acceptable to the authority having jurisdiction and concerned with product evaluation, that maintains periodic inspection of production of labeled equipment or materials, and by whose labeling the manufacturer indicates compliance with appropriate standards or performance in a specified manner.

**3.2.4\* Listed.** Equipment, materials, or services included in a list published by an organization that is acceptable to the authority having jurisdiction and concerned with evaluation of products or services, that maintains periodic inspection of production of listed equipment or materials or periodic evaluation of services, and whose listing states that either the equipment, material, or service meets appropriate designated standards or has been tested and found suitable for a specified purpose.

**3.2.5 Shall.** Indicates a mandatory requirement.

**3.2.6 Should.** Indicates a recommendation or that which is advised but not required.

**3.2.7 Standard.** An NFPA Standard, the main text of which contains only mandatory provisions using the word "shall" to indicate requirements and that is in a form generally suitable for mandatory reference by another standard or code or for adoption into law. Nonmandatory provisions are not to be considered a part of the requirements of a standard and shall be located in an appendix, annex, footnote, informational note, or other means as permitted in the NFPA Manuals of Style. When used in a generic sense, such as in the phrase "standards development process" or "standards development activities," the term "standards" includes all NFPA Standards,

including Codes, Standards, Recommended Practices, and Guides.

### 3.3 General Definitions.

**3.3.1 Combustible Liquid.** Any liquid that has a closed-cup flash point at or above 100°F (38°C), as determined by the test procedures and apparatus set forth in Section 4.4 of NFPA 30. [30, 2018]

**3.3.1.1 Class II Liquid.** A liquid that has a closed-cup flash point at or above 100°F (38°C) and below 140°F (60°C). [30, 2018]

**3.3.1.2 Class IIIA Liquid.** Any Liquid that has a closed-cup flash point at or above 140°F (60°C), but below 200°F (93°C). [30, 2018]

**3.3.1.3 Class IIIB Liquid.** Any liquid that has a closed-cup flash point at or above 200°F (93°C). [30, 2018]

**3.3.2\* Concentration.** The percent of foam concentrate contained in a foam solution.

**3.3.3\* Discharge Devices.** Devices designed to discharge water or foam-water solution in a predetermined, fixed, or adjustable pattern.

**3.3.3.1 Air-Aspirating Discharge Devices.** Devices specially designed to aspirate and mix air into the foam solution to generate foam, followed by foam discharge in a specific design pattern.

**3.3.3.2 Compressed Air Foam Discharge Devices.** Devices specifically designed to discharge compressed air foam in a predetermined pattern.

**3.3.3.3\* Non-Air-Aspirating Discharge Devices.** Devices designed to provide a specific water discharge pattern.

### 3.3.4 Discharge Outlet.

**3.3.4.1 Fixed Foam Discharge Outlet.** A device permanently attached to a tank, dike, or other containment structure, designed to introduce foam.

**3.3.4.2\* Type I Discharge Outlet.** An approved discharge outlet that conducts and delivers foam gently onto the liquid surface without submergence of the foam or agitation of the surface.

**3.3.4.3 Type II Discharge Outlet.** An approved discharge outlet that does not deliver foam gently onto the liquid surface but is designed to lessen submergence of the foam and agitation of the surface.

**3.3.5\* Eductor (Inductor).** A device that uses the Venturi principle to introduce a proportionate quantity of foam concentrate into a water stream; the pressure at the throat is below atmospheric pressure and will draw in liquid from atmospheric storage.

**3.3.5.1\* In-Line Eductor.** A Venturi-type proportioning device that meters foam concentrate at a fixed or variable concentration into the water stream at a point between the water source and a nozzle or other discharge device.

**3.3.6 Expansion.** The ratio of final foam volume to original foam solution volume.

**3.3.7 Film Formation.** A property of aqueous film-forming foams and film-forming fluoroproteins characterized by a posi-

tive (>0.0 dynes/cm) spreading coefficient when measured according to ASTM D1331 using cyclohexane as the hydrocarbon substrate and distilled water to make the foam solution.

### 3.3.8 Fire.

**3.3.8.1 Class A Fire.** A fire in ordinary combustible materials, such as wood, cloth, paper, rubber, and many plastics. [10, 2018]

**3.3.8.2 Class B Fire.** A fire in flammable liquids, combustible liquids, petroleum greases, tars, oils, oil-based paints, solvents, lacquers, alcohols, and flammable gases.

**3.3.9 Flammable (Class D) Liquid.** Any liquid that has a closed-cup flash point that is below 100°F (38°C), as determined by the test procedures and apparatus set forth in Section 4.4 of NFPA 30, and a Reid vapor pressure that does not exceed an absolute pressure of 40 psi (3 bar) at 100°F (38°C), as determined by ASTM D323, *Standard Test Method for Vapor Pressure of Petroleum Products (Reid Method)*. [30, 2018]

**3.3.9.1 Class IA Liquid.** Any liquid that has a closed-cup flash point below 73°F (23°C) and a boiling point below 100°F (38°C). [30, 2018]

**3.3.9.2 Class IB Liquid.** Any liquid that has a closed-cup flash point below 73°F (23°C) and a boiling point at or above 100°F (38°C). [30, 2018]

**3.3.9.3 Class IC Liquid.** Any liquid that has a closed-cup flash point at or above 73°F (23°C) but below 100°F (38°C). [30, 2018]

**3.3.10\* Foam.** A stable aggregation of bubbles of lower density than oil or water.

**3.3.10.1 Compressed Air Foam (CAF).** Homogeneous, micro-size foam bubbles produced by the combination of water, foam concentrate, and air or nitrogen under pressure.

**3.3.11 Foam Chamber.** See 3.3.4.1, Fixed Foam Discharge Outlet.

**3.3.12\* Foam Concentrate.** A concentrated liquid foaming agent as received from the manufacturer.

**3.3.12.1\* Alcohol-Resistant Foam Concentrate.** A concentrate used for fighting fires on water-soluble materials and other fuels destructive to regular, AFFF, SFFF, or FFFP foams, as well as for fires involving hydrocarbons.

**3.3.12.2\* Aqueous Film-Forming Foam Concentrate (AFFF).** A concentrate based on fluorinated surfactants plus foam stabilizers to produce a fluid aqueous film for suppressing hydrocarbon fuel vapors and usually diluted with water to a 1 percent, 3 percent, or 6 percent solution.

**3.3.12.3\* Film-Forming Fluoroprotein Foam Concentrate (FFFP).** A protein-foam concentrate that uses fluorinated surfactants to produce a fluid aqueous film for suppressing hydrocarbon fuel vapors.

**3.3.12.4 Film-Forming Foam.** A concentrate that when mixed at its nominal use concentration will form an aqueous film on hydrocarbon fuels.

**3.3.12.5\* Fluoroprotein Foam Concentrate.** A concentrate very similar to protein-foam concentrate but with a synthetic fluorinated surfactant additive.

**3.3.12.6\* Medium- and High-Expansion Foam Concentrate.** A concentrate, usually derived from hydrocarbon surfactants, used in specially designed equipment to produce foams having foam-to-solution volume ratios of 20:1 to approximately 1000:1.

**3.3.12.7\* Protein Foam Concentrate.** Concentrate consisting primarily of products from a protein hydrolysate, plus stabilizing additives and inhibitors to protect against freezing, to prevent corrosion of equipment and containers, to resist bacterial decomposition, to control viscosity, and to otherwise ensure readiness for use under emergency conditions.

**3.3.12.8\* Synthetic Fluorine-Free Foam (SFFF).** Foam concentrate based on a mixture of hydrocarbon surface active agents that is not formulated to contain per- or poly-fluoroalkyl substances (PFAS).

**3.3.12.9 Synthetic Foam Concentrate.** Concentrate based on foaming agents other than hydrolyzed proteins and including aqueous film-forming foam (AFFF) concentrates, medium- and high-expansion foam concentrates, and other synthetic foam concentrates.

**3.3.12.9.1\* Other Synthetic Foam Concentrate.** A concentrate based on hydrocarbon surface active agents and listed as a wetting agent, foaming agent, or both.

**3.3.13 Foam Concentrate Type.** A classification of a foam concentrate that includes the chemical composition as defined under foam concentrate (see 3.3.12), including the use percentage, the minimum usable temperature, and the fuels on which the concentrate is effective.

### 3.3.14 Foam Generators.

**3.3.14.1 Foam Generators — Aspirator Type.** Foam generators, fixed or portable, in which jet streams of foam solution aspirate sufficient amounts of air that is then entrained on the screens to produce foam, and which usually produce foam with expansion ratios of not more than 250:1.

**3.3.14.2\* Foam Generators — Blower Type.** Foam generators, fixed or portable, in which the foam solution is discharged as a spray onto screens through which an airstream developed by a fan or blower is passing.

### 3.3.15 Foam Injection.

**3.3.15.1 Semisubsurface Foam Injection.** Discharge of foam at the liquid surface within a storage tank from a floating hose that rises from a piped container near the tank bottom.

**3.3.15.2 Subsurface Foam Injection.** Discharge of foam into a storage tank from an outlet near the tank bottom.

**3.3.16\* Foam Solution.** A homogeneous mixture of water and foam concentrate in the correct proportions.

**3.3.16.1 Premixed Foam Solution.** Solution produced by introducing a measured amount of foam concentrate into a given amount of water in a storage tank.

### 3.3.17 Foam System Types.

**3.3.17.1\* Compressed Air Foam System (CAFS).** A system employing compressed air foam discharge nozzles, Type II and Type III applicators/devices, or hoses attached to a fixed piping system through which foam is transported from a mixing chamber.

**3.3.17.2 Fixed Systems.** A complete installation in which foam is piped from a central foam station, discharging through fixed delivery outlets to the hazard to be protected with permanently installed pumps where required.

**3.3.17.2.1\* Foam-Water Sprinkler System.** A piping network employing automatic sprinklers, nozzles, or other discharge devices, connected to a source of foam concentrate and to a water supply.

**3.3.17.2.1.1\* Foam-Water Deluge System.** A foam-water sprinkler system employing open discharge devices, which are attached to a piping system that is connected to a water supply through a valve that is opened by the operation of a detection system, which is installed in the same areas as the discharge devices.

**3.3.17.2.1.2\* Foam-Water Dry Pipe System.** A foam-water sprinkler system employing automatic sprinklers or nozzles that are attached to a piping system that contains air or nitrogen under pressure, the release of which (as from the opening of a sprinkler) permits the water pressure to open a valve known as a dry pipe valve.

**3.3.17.2.1.3\* Foam-Water Preaction System.** A foam-water sprinkler system employing automatic sprinklers or nozzles attached to a piping system containing air that might or might not be under pressure, with a supplemental detection system installed in the same area as the sprinklers.

**3.3.17.2.1.4\* Foam-Water Spray System.** A foam-water sprinkler system designed to use nozzles rather than sprinklers.

**3.3.17.2.1.5\* Preprimed System.** A wet pipe system containing foam solution.

**3.3.17.3\* Mobile System.** Any type of foam-producing unit that is mounted on wheels and that is self-propelled or towed by a vehicle and can be connected to a water supply or can utilize a premixed foam solution.

**3.3.17.4 Portable System.** Foam-producing equipment, materials, hose, and so forth that are transported by hand.

**3.3.17.5\* Semifixed System.** A system in which the hazard is equipped with fixed discharge outlets connected to piping that terminates at a safe distance.

**3.3.18\* Foam-Generating Methods.** Methods of generation of air foam including hose stream, foam nozzle, and medium- and high-expansion generators, foam maker, pressure foam maker (high back pressure or forcing type), or foam monitor stream.

**3.3.18.1\* Compressed Air Foam-Generating Method.** A method of generating compressed air foam recognized in this standard by using a mixing chamber to combine air or nitrogen under pressure, water, and foam concentrate in the correct proportions.

**3.3.19 Foam-Water Density.** The unit rate of foam-water solution application to an area, expressed in gpm/ft<sup>2</sup> (mm/min).

**3.3.20\* Handline.** A hose and nozzle that can be held and directed by hand.

**3.3.21 Inductor** See 3.3.5.

### 3.3.22 Inspection, Testing, and Maintenance.

**3.3.22.1 Inspection.** A visual examination of a system or portion thereof to verify that it appears to be in operating condition and is free of physical damage. [820, 2016]

**3.3.22.2 Maintenance.** In water-based fire protection systems, work performed to keep equipment operable. [25, 2020]

**3.3.22.3 Test.** The operation of a device to verify that it is functioning correctly, or the measurement of a system characteristic to determine if it meets requirements. [25, 2020]

**3.3.22.4 Testing.** A procedure used to determine the operational status of a component or system by conducting periodic physical checks, such as waterflow tests, fire pump tests, alarm tests, and trip tests of dry pipe, deluge, or preaction valves. [25, 2020]

### 3.3.23 Monitor.

**3.3.23.1\* Fixed Monitor (Cannon).** A device that delivers a large foam stream and is mounted on a stationary support that either is elevated or is at grade.

**3.3.23.2 Portable Monitor (Cannon).** A device that delivers a foam monitor stream and is mounted on a movable support or wheels so it can be transported to the fire scene.

### 3.3.24 Nozzle.

**3.3.24.1\* Foam Nozzle or Fixed Foam Maker.** A specially designed hoseline nozzle or fixed foam maker designed to aspirate air that is connected to a supply of foam solution.

**3.3.24.2\* Self-Educting Nozzle.** A device that incorporates a venturi to draw foam concentrate through a short length of pipe and/or flexible tubing connected to the foam supply.

**3.3.25\* Pressure Foam Maker (High Back Pressure or Forcing Type).** A foam maker utilizing the Venturi principle for aspirating air into a stream of foam solution forms foam under pressure.

**3.3.26 Proportioning.** The continuous introduction of foam concentrate at the recommended ratio into the water stream to form foam solution.

**3.3.26.1\* Balanced Pressure Pump-Type Proportioning.** A foam proportioning system that utilizes a foam pump and valve(s) to balance foam and water pressures at a modified venturi-type proportioner located in the foam solution delivery piping; a foam concentrate metering orifice is fitted in the foam inlet section of the proportioner.

**3.3.26.1.1\* In-Line Balanced Pressure Proportioning.** A foam proportioning system utilizing a foam concentrate pump or a bladder tank in conjunction with a listed pressure reducing valve. At all design flow rates, the constant foam concentrate pressure is greater than the maximum water pressure at the inlet to the in-line balanced pressure proportioner. A pressure balancing valve integral to the in-line balanced pressure proportioner regulates the foam concentrate pressure to be balanced to incoming water pressure.

**3.3.26.2\* Coupled Water-Motor Driven Pump Proportioning.** A correctly designed positive displacement water motor in the water supply line coupled to a positive displacement foam concentrate pump to provide proportioning.

**3.3.26.3\* Direct Injection Variable Pump Output Proportioning.** A direct injection proportioning system that utilizes flowmeters for foam concentrate and water in conjunction with a variable output foam pump control system.

**3.3.27 Proportioning Methods for Foam Systems.** The methods of proportioning used to create the correct solution of water and foam liquid concentrate.

**3.3.28\* Pump Proportioner (Around-the-Pump Proportioner).** A system that uses a venturi eductor installed in a bypass line between the discharge and suction side of a water pump and suitable variable or fixed orifices to induct foam concentrate from a tank or container into the pump suction line.

### 3.3.29 Stream.

**3.3.29.1 Foam Hose Stream.** A foam stream from a handline.

**3.3.29.2 Foam Monitor Stream.** A large capacity foam stream from a nozzle that is supported in position and can be directed by one person.

**3.3.30\* Spreading Coefficient.** The measurement of a foam solution's potential to spread spontaneously across a hydrocarbon surface.

### 3.3.31 Storage Tank Roofs.

**3.3.31.1\* Cone Roof.** A fixed structural steel conical or dome roof permanently attached to the exterior tank shell.

**3.3.31.2\* External Floating Roof.** A roof system fitted to the inside diameter of a storage tank designed to automatically adjust to fluctuating liquid levels and is exposed to the atmosphere.

**3.3.31.3\* Internal Floating Roof.** A roof system fitted to the inside diameter of a storage tank designed to automatically adjust to fluctuating liquid levels; covered completely by a permanently fixed structural steel cone or dome roof system attached to the exterior tank shell.

### 3.3.32 Tank.

**3.3.32.1 Balanced Pressure Bladder Tank.** A foam concentrate tank fitted with an internal bladder that uses waterflow through a modified venturi-type proportioner to control the foam concentrate injection rate by displacing the foam concentrate within the bladder with water outside the bladder.

**3.3.32.2\* Pressure Proportioning Tank.** A foam concentrate tank with no bladder that uses waterflow through an orifice to displace a foam concentrate, having a specific gravity of at least 1.15, in the tank with water to add foam concentrate through an orifice into a water line at a specified rate.

## Chapter 4 System Components and System Types

**4.1\* General.** This chapter shall provide requirements for the correct use of foam system components.

**4.1.1\*** All components shall be listed for their intended use.

**4.1.2** Foam concentrate shall be listed for use with the proportioning equipment and discharge device(s).

**4.1.3** Where listings for components do not exist, components shall be approved.

## **4.2 Water Supplies.**

### **4.2.1 Water Supplies for Low-Expansion Foam Tank, Fueling, and Spill Area Systems.**

#### **4.2.1.1\* Quality.**

**4.2.1.1.1** The water supply to foam systems shall be permitted to be hard or soft, fresh or salt, but shall be of a quality such that adverse effects on foam formation or foam stability do not occur.

**4.2.1.1.2** No corrosion inhibitors, emulsion breaking chemicals, or any other additives shall be present without prior consultation with the foam concentrate supplier.

**4.2.1.1.3** Water that contains solids likely to clog orifices in discharge devices but that is otherwise acceptable for making foam shall be permitted to be used after passing through line strainers.

**4.2.1.2\* Quantity.** The water supply shall be of a quantity to supply all the devices that shall be permitted to be used simultaneously for the specified time.

**4.2.1.2.1** This quantity shall include not only the volume required for the foam apparatus but also water that shall be permitted to be used in other firefighting operations, in addition to the normal plant requirements.

**4.2.1.2.2** Premixed solution-type systems shall not be required to be provided with a continuous water supply.

**4.2.1.3 Pressure.** The pressure at the inlet to the foam system (e.g., foam generator, air foam maker) under required flow conditions shall be at least the minimum pressure for which the system has been designed.

**4.2.1.4\* Temperature.** Optimum foam production shall be obtained by using water at temperatures between 40°F (4°C) and 100°F (38°C).

**4.2.1.5 Design.** The water supply system shall be designed and installed in accordance with NFPA 24.

**4.2.1.5.1** Strainers shall be provided where solids of a size large enough to obstruct openings or damage equipment are present.

**4.2.1.5.2** Hydrants furnishing the water supply for foam equipment shall be provided in the required number.

**4.2.1.5.3** Hydrants shall be located as required by the authority having jurisdiction (AHJ).

**4.2.1.6 Storage.** Water supply or premixed solution shall be protected against freezing in climates where freezing temperatures are expected.

### **4.2.2 Water Supplies for Foam-Water Sprinkler and Spray Systems.**

#### **4.2.2.1 Water Quality.**

**4.2.2.1.1** Water supplied to foam-water systems shall be compatible with the foam concentrate to be used.

**4.2.2.1.2** Water that contains solids likely to clog orifices in discharge devices but that is otherwise acceptable for making

foam shall be permitted to be used after passing through line strainers.

#### **4.2.2.2 Water Supply Capacity, Pressure, and Duration.**

**4.2.2.2.1** Water supplies for deluge foam-water sprinkler systems and foam-water spray systems shall be automatic.

**4.2.2.2.2** Water supplies shall have the capacity and a pressure to maintain foam and/or water discharge, or both, at the required design rate for the required duration over the area protected by the systems that are expected to operate simultaneously.

**4.2.2.2.3\*** Where the water supply is dependent on public water sources, attention shall be given to the pollution hazard introduced by the use of foam concentrate.

**4.2.2.2.4** Cross-connections shall be reviewed by public health agencies concerned.

#### **4.2.2.3 Duration.**

**4.2.2.3.1\*** Water supplies shall be designed to meet the fixed fire protection demand plus 250 gpm (946 L/min) for inside and outside hose streams for at least 60 minutes, unless otherwise specified in the occupancy standards.

**4.2.2.3.2** Water supplies for aircraft hangars shall be in accordance with NFPA 409.

### **4.2.3 Fire Department Connections.**

**4.2.3.1\*** Unless the requirements of 4.2.3.2 or 4.2.3.3 are met, the fire department connection(s) shall consist of two 2½ in. (65 mm) connections using NH internal threaded swivel fitting(s) with "2.5-7.5 NH standard thread," as specified in NFPA 1963. [13:16.12.3.1]

**4.2.3.2** Where local fire department connections do not conform to NFPA 1963, the authority having jurisdiction shall be permitted to designate the connection to be used. [13:16.12.3.1.1]

**4.2.3.3** The use of threadless couplings shall be permitted where required by the authority having jurisdiction and where listed for such use. [13:16.12.3.1.2]

**4.2.3.4** Fire department connections shall be equipped with listed plugs or caps, properly secured and arranged for easy removal by fire departments. [13:16.12.3.2]

**4.2.3.5** Fire department connections shall be of an approved type. [13:16.12.3.3]

### **4.2.4 Water and Foam Concentrate Pumps.**

**4.2.4.1** When water or foam concentrate pumps are required for automatic or manual foam system operation, they shall be designed and installed in accordance with NFPA 20.

## **4.3 Foam Concentrates.**

### **4.3.1 Types of Foam Concentrate.**

**4.3.1.1\*** Foam concentrate shall be listed for use with the foam concentrate proportioning equipment and with the discharge devices with which a given system is equipped.

**4.3.1.1.1** Replacement supplies of foam concentrates shall be listed for use with system components.



**4.3.1.1.2\*** Different types and/or brands of foam concentrates shall not be mixed for storage. Different brands of the same type of concentrate shall not be mixed unless data are provided by the manufacturer and accepted by the AHJ, to prove that the brands are compatible.

**4.3.1.2\*** The concentrate used in a foam system shall be listed for use on the specific flammable or combustible liquid to be protected.

**4.3.1.2.1** Water-miscible and polar flammable or combustible liquids shall be protected by alcohol-resistant concentrates listed for this purpose.

**4.3.1.3** The limitations of the listing and the manufacturers' specifications shall be followed.

**4.3.1.4** Acceptable ranges for the following physiochemical properties of the foam concentrate shall be published as part of the listing to determine compliance with 13.2.6.2:

- (1) Density or specific gravity
- (2) pH
- (3) Refractive index
- (4)\* Viscosity

#### **4.3.2 Concentrate Storage.**

##### **4.3.2.1 Storage Facilities.**

**4.3.2.1.1** Foam concentrates and equipment shall be stored in a location not exposed to the hazard they protect.

**4.3.2.1.2** If housed, foam concentrates and equipment shall be in a noncombustible structure.

**4.3.2.1.3** For outdoor nonautomatic systems, the AHJ shall be permitted to approve the storage of foam concentrate in a location off premises where these supplies are available at all times.

**4.3.2.1.4** Loading and transportation facilities for foam concentrates shall be provided.

**4.3.2.1.5** Off-premises supplies shall be of the type required for use in the systems of the given installation.

**4.3.2.1.6** At the time of a fire, these off-premises supplies shall be accumulated in the required quantities, before the equipment is placed in operation, to ensure uninterrupted foam production at the design rate for the required period of time.

**4.3.2.2\* Quantity.** The amount of concentrate shall meet the discharge requirements for the largest single hazard protected or group of hazards that are to be protected simultaneously.

##### **4.3.2.3 Foam Concentrate Storage Tanks.**

**4.3.2.3.1** Bulk liquid storage tanks shall be fabricated from or be lined with materials compatible with the concentrate.

**4.3.2.3.1.1** Storage tanks for foam concentrate shall be solidly mounted and shall be permanently located.

**4.3.2.3.1.2** The storage tank shall be designed to minimize evaporation of foam concentrate.

**4.3.2.3.1.3\*** Proportioning systems shall have signage to provide instruction on the proper sequence of system shut-down to prevent accidental loss of foam concentrate and/or system damage.

**4.3.2.3.1.4** In atmospheric storage tanks, the suction inlet shall be located a minimum of 1 in. (25 mm) above the bottom of the tank.

**4.3.2.3.1.5** Foam concentrate below the level of the suction inlet shall not be considered usable.

##### **4.3.2.3.2 Atmospheric-Type Storage Tanks.**

**4.3.2.3.2.1** Storage tanks shall have capacities to accommodate the needed quantities of foam concentrate plus space for thermal expansion.

**4.3.2.3.2.2** Foam concentrate outlets from the tanks shall be located to prevent sediment from being drawn into the system.

**4.3.2.3.2.3** When determining the quantity of foam concentrates, the volume of the sediment pocket shall be added to the quantity needed for system operation.

**4.3.2.3.2.4\*** Tanks shall be equipped with conservation-type vents, access handholes, or manholes that are located to provide for inspection of the following:

- (1) Interior tank surfaces
- (2) Connections for pump suction, relief, and testing lines
- (3) Protected sight gauges or other liquid level devices
- (4) Filling and draining connections

**4.3.2.3.2.5** Tank discharge outlets shall be located to furnish a positive head on the pump suction.

##### **4.3.2.3.3 Pressure-Type Storage Tanks.**

**4.3.2.3.3.1\*** Pressure-proportioning tanks shall have means for filling, for gauging the level of foam concentrates, and for drainage, cleaning, and inspection of interior surfaces and of the concentrate-holding bladder or diaphragm, if provided.

**4.3.2.3.3.2** These tanks shall be stamped to be identified as meeting the requirements of ASME *Boiler and Pressure Vessel Code*, Section VIII, Division 1.

##### **4.3.2.4 Storage Conditions.**

**4.3.2.4.1\*** In order to ensure the correct operation of any foam-producing system, the chemical and physical characteristics of the materials comprising the system shall be taken into consideration in design.

**4.3.2.4.2\*** Foam concentrates shall be stored within the listed temperature limitations.

**4.3.2.4.3** Markings shall be provided on storage vessels to identify the type of concentrate and its intended concentration in solution.

##### **4.3.2.5 Foam Concentrate Supply.**

**4.3.2.5.1 Foam Concentrate Consumption Rates.** The consumption rates shall be based on the percentage concentrate used in the system design (e.g., 3 percent or 6 percent or other, if so listed or approved by the AHJ).

##### **4.3.2.5.2 Reserve Supply of Foam Concentrate.**

**4.3.2.5.2.1** There shall be a reserve supply of foam concentrate to meet design requirements in order to put the system back into service after operation.

**4.3.2.5.2.2** The reserve supply shall be in separate tanks or compartments, in drums or cans on the premises, or shall be

able to be obtained from an approved outside source within 24 hours.

**4.3.2.6 Auxiliary Supplies.** Other equipment necessary to recommission the system, such as bottles of nitrogen or carbon dioxide for premixed systems, also shall be able to be secured.

#### 4.4 Concentrate Compatibility.

##### 4.4.1 Compatibility of Foam Concentrates.

**4.4.1.1\*** Different types of foam concentrates shall not be mixed for storage.

**4.4.1.2** Different brands of the same type of concentrate shall not be mixed unless data are provided by the manufacturer and accepted by the AHJ to prove that they are compatible.

**4.4.1.3** Low-expansion foams generated separately from protein, fluoroprotein, FFFP, AFFF, SFFF, and alcohol-resistant concentrates shall be permitted to be applied to a fire in sequence or simultaneously.

##### 4.4.2\* Foam Compatibility with Dry Chemical Agents.

**4.4.2.1** The manufacturers of the dry chemical and foam concentrate to be used in the system shall confirm that their products are mutually compatible.

**4.4.2.2** Where used, limitations imposed on either of the agents alone shall be applied.

**4.5 Foam Proportioning.** The method of foam proportioning shall conform to one of the following:

- (1) Self-educing nozzle
- (2) In-line eductor
- (3) Pressure proportioners (with or without bladder)
- (4) Around-the-pump proportioners
- (5) Direct injection variable output foam pump system
- (6) Coupled water-motor driven pump proportioner
- (7) Balanced pressure pump-type proportioners

**4.5.1\*** The proportioning system shall meet the listed minimum flow rate based on the minimum and maximum system discharge flow rate.

##### 4.5.2 Fixed Foam Concentrate Proportioning Means.

**4.5.2.1** Balanced-pressure or positive-pressure injection shall be the preferred methods for introduction of foam concentrates into the water flowing through the supply piping to the system.

**4.5.2.2\*** Balanced-pressure injection methods shall be one of the following:

- (1) A balanced-pressure proportioning system utilizing a foam concentrate pump discharging through a metering orifice into a proportioning controller with the foam concentrate and water pressures automatically maintained as equal by the use of a pressure balancing valve.
- (2) A balanced-pressure proportioning system utilizing a pressure proportioning tank with a diaphragm or bladder to separate the water and foam concentrate discharging through a metering orifice into a proportioning controller.
- (3) An in-line balanced-pressure proportioning system utilizing a foam concentrate pump or bladder tank. A pressure regulating device placed in the pump return line shall maintain constant pressure in the foam concentrate

supply line at all design flow rates. This constant pressure shall be greater than the maximum water pressure under all operating conditions.

- (4) Foam concentrate pump discharging through a metering orifice into the protection system riser with the foam pressure at the upstream side of the orifice exceeding the water pressure in the system riser by a specific design value.

**4.5.2.3** Other listed methods for foam proportioning shall be permitted as follows:

- (1) Balanced positive-pressure injection systems utilizing a foam concentrate pump and drive motor that vary the foam concentrate pump output to match water flow rates while maintaining the correct percentage of foam concentrate
- (2) Around-the-pump proportioners
- (3)\* In-line eductors (inductors)

**4.5.2.4\*** The exposed orifice plate indicator tab or nameplate shall have stamped, etched, engraved, or other permanent markings giving orifice diameters and an indication of the flow direction if flow characteristics vary with flow direction.

#### 4.6\* Foam Concentrate Pumps.

**4.6.1\* Materials.** The design and materials of construction for foam concentrate pumps shall be approved for use with the type of foam concentrate used in the system.

##### 4.6.2 Rated Capacities.

**4.6.2.1** Foam concentrate pumps shall have rated capacities at or in excess of the maximum system demand.

**4.6.2.2** To ensure positive injection of foam concentrate, the discharge pressure ratings of pumps at the design discharge capacity shall be in excess of the maximum water pressure available under any condition at the point of foam concentrate injection.

##### 4.6.3 Overpressurization.

**4.6.3.1\*** Foam concentrate pumps capable of overpressurizing the system shall be provided with means of pressure relief from the discharge to the supply side of the pump to prevent excessive pressure and temperature.

**4.6.3.2** Overpressure shall not exceed the working pressure of the foam concentrate piping system.

##### 4.6.4 Flushing.

**4.6.4.1\*** Foam concentrate pumps shall have means for flushing.

**4.6.4.2** Foam concentrate pumps shall be provided with a drain cock or valve.

**4.6.5** Foam concentrate pumps shall be automatic-starting upon system actuation.

**4.6.6** Pumps shall be listed for this service in accordance with NFPA 20.

**4.6.7\*** Seals or packing shall be compatible with the foam concentrate.

**4.6.8** A foam concentrate pump shall have the capacity to meet the actual maximum flow rate at the highest proportioning flow rate as permitted by 12.6.5 or the AHJ.

**4.6.9** Foam concentrate pumps shall have rated capacities sufficient to meet the maximum system flow rate, as determined by 9.3.7.5.

#### **4.7 Piping.**

##### **4.7.1\* Foam Concentrate Pipe Materials.**

**4.7.1.1\*** Foam concentrate pipe and valves shall be made of one of the following materials:

- (1) Brass (red or naval)
- (2) Bronze
- (3) Stainless steel (304 or 316)
- (4) Copper nickel 90/10
- (5) Other material, in accordance with the foam concentrate manufacturer's certification of compatibility with the foam concentrate and as approved by the AHJ

**4.7.1.2\*** Carbon steel pipe shall not be used.

**4.7.1.3** Pipe carrying foam concentrate shall not be galvanized.

**4.7.1.4** Foam concentrate pipe shall conform to one of the following standards:

- (1) ASTM A312/A312M
- (2) ASTM B43
- (3) ASTM B315
- (4) Other standards as allowed by 4.7.1.1(5), 4.7.1.2, and 4.7.1.3

**4.7.1.5** In piping with dissimilar metals, dielectric components shall be used to insulate and reduce the possibility of galvanic corrosion.

**4.7.1.6** Selection of pipe wall thickness shall conform to one of the following:

- (1) Schedule 40
- (2) ASME B31.1

**4.7.1.7\*** For the purpose of computing friction loss in the foam concentrate piping, the following shall be used:

- (1) Darcy-Weisbach formula for (Newtonian) foam concentrates
- (2) Manufacturers' friction loss data for alcohol-resistant (non-Newtonian) foam concentrates

**4.7.1.8** Flushing and drainage valves/connections for dry foam concentrate piping shall be installed in the standby condition.

**4.7.1.9\*** Dry foam concentrate piping shall be pitched a minimum of  $\frac{1}{2}$  in. over 10 ft (4 mm/m) to allow for drainage.

##### **4.7.2\* Foam Solution Pipe Materials.**

**4.7.2.1\*** Foam solution pipe shall be made of one of the following materials:

- (1) Galvanized steel
- (2) Stainless steel
- (3) Copper nickel 90/10
- (4) Internal/external corrosion-resistant pipe in accordance with the foam manufacturer's specification for compatibility and acceptable to the authority having jurisdiction
- (5) Unprotected carbon steel pipe when filled with foam solution or water and the discharge devices are closed to the atmosphere

**4.7.2.2** Where exposed to corrosive influences, the piping shall be corrosion resistant or protected against corrosion.

**4.7.2.3** Pipe within the hazard area shall be rated for the pressure and temperature involved.

**4.7.2.4** Pipe within the hazard area shall be able to withstand the anticipated exposure to fire.

**4.7.2.5** Nonmetallic foam solution piping shall be listed for the intended application.

**4.7.2.6** Metallic foam solution pipe shall not be less than standard weight.

**4.7.2.7** Foam solution pipe shall conform to one of the following standards:

- (1) ASTM A53/A53M
- (2) ASTM A135/A135M
- (3) ASTM A795/A795M
- (4) Other standards as allowed in 4.7.2.1(4)

**4.7.2.8** Underground foam solution pipe shall be installed in accordance with NFPA 24.

**4.7.2.8.1** Piping materials and specifications shall be in accordance with this standard.

**4.7.2.9** For the purpose of computing friction loss in foam solution piping, the following C-values shall be used for the Hazen-Williams formula:

- (1) Galvanized steel pipe — 120
- (2) Other C-values for corrosion-resistant piping materials in accordance with NFPA 13

**4.7.2.10** Foam solution distribution piping shall be pitched a minimum of  $\frac{1}{2}$  in. over 10 ft (4 mm/m) to allow for drainage.

#### **4.7.3 Fittings.**

##### **4.7.3.1\* Foam Concentrate Fittings.**

**4.7.3.1.1** Foam concentrate piping shall use fittings made of the following materials, as appropriate to the foam concentrate pipe material:

- (1) Brass (red or naval)
- (2) Bronze
- (3) Stainless steel (304 or 316)
- (4) Other material, in accordance with the foam concentrate manufacturer's certification of compatibility, with approval from the AHJ, and as permitted by 4.7.3.1.2

**4.7.3.1.2** Foam concentrate fittings shall not be carbon steel or galvanized.

**4.7.3.1.3** Foam concentrate fittings shall not be less than standard class weight.

**4.7.3.1.4** Foam concentrate fitting shall be in accordance with one of the following or as permitted by the AHJ:

- (1) ASME B16.5
- (2) ASME B16.11
- (3) ASME B16.15
- (4) ASME B16.24

##### **4.7.3.2 Foam Solution Fittings.**

**4.7.3.2.1** Foam solution fittings shall be one of the following:

- (1) Galvanized steel

- (2) Stainless steel
- (3) Other material, in accordance with the manufacturer's certification of compatibility and with approval of the AHJ
- (4) Unprotected carbon steel pipe, when discharge devices are closed to the atmosphere
- (5) Internally/externally coated materials that are listed for the application

**4.7.3.2.2** Foam solution fittings shall not be less than standard class weight.

**4.7.3.2.3** Foam solution fittings shall be in accordance with one of the following or as permitted by the AHJ:

- (1) ASME B16.1
- (2) ASME B16.3
- (3) ASME B16.4
- (4) ASME B16.5
- (5) ASME B16.9
- (6) ASME B16.11
- (7) ASME B16.25
- (8) ASTM A234/A234M

**4.7.3.2.4** Cast-iron fittings shall not be used where dry sections of piping are exposed to possible fire or where fittings are subject to stress in self-supporting systems.

**4.7.3.2.5** Listed rubber or other elastomeric-gasketed fittings shall be permitted to be used in fire-exposed areas if the foam system is actuated automatically.

**4.7.3.2.6** Listed rubber or other elastomeric-gasketed fittings shall be permitted to be used in fire-exposed areas if the foam system is actuated manually and high-temperature-rated extra-heavy-duty grooved fittings and gaskets have been tested in accordance with API STD 607 and meet these criteria within industry standards.

#### **4.7.4 Joining of Pipes and Fittings.**

##### **4.7.4.1 Threaded Pipe.**

**4.7.4.1.1** Pipe threading shall be in conformance with ASME B1.20.1 or ISO 7-1.

**4.7.4.1.2** PTFE tape or the foam concentrate manufacturer's compatible thread-locking compounds shall be used at pipe joints in the foam concentrate supply line.

**4.7.4.2 Grooved Pipe.** Dimensions of cut- and roll-grooves and outside diameters of piping materials shall conform to the manufacturers' recommendations and the listing laboratories' certifications.

##### **4.7.4.3\* Welded Pipe.**

**4.7.4.3.1** Field welding shall conform to the requirements of AWS B2.1/B2.1M or equivalent.

**4.7.4.3.2** Shop welding shall conform to the requirements of Section 6.5 in NFPA 13.

**4.7.4.3.3** Precautions shall be taken to ensure that the openings are fully cut out and that no obstructions remain in the waterway.

**4.7.4.3.4** Precautions shall be taken to ensure that no galvanic corrosion occurs between piping and fittings.

#### **4.7.5 Strainers.**

**4.7.5.1** Strainers shall be provided where solids of a size large enough to obstruct openings or damage equipment are present.

**4.7.5.2** The ratio of the strainer's open basket area to its inlet pipe area shall be at least 10:1.

**4.7.5.2.1** The net open area of the strainer shall be at least four times the area of the suction piping.

**4.7.5.2.2** Strainer mesh size shall be in accordance with the pump manufacturer's recommendations based on foam concentrate viscosity.

#### **4.7.6\* Valves.**

**4.7.6.1** All valves for water and foam solution lines shall be of the indicator type, such as OS&Y or post indicator.

**4.7.6.2** Automatic valves for foam concentrate lines shall be listed for this service.

**4.7.6.3** Valve specifications for water use shall be permitted outside the hazard or diked area.

**4.7.6.4** Inside the hazard or diked area, automatic control valves and shutoff valves shall be of steel or other alloy capable of withstanding exposure to fire temperatures.

**4.7.6.5\* Valve Supervision.** All valves (main water, foam concentrate, and foam solution) required for automatic foam systems shall be supervised in their operating position by one of the following methods:

- (1) Central station, proprietary, or remote station signaling service in accordance with *NFPA 72*
- (2) Local signaling service that will cause the sounding of an audible signal at a constantly attended location in accordance with *NFPA 72*
- (3) Valves locked in the open position
- (4) Valves located within fenced enclosures under the control of the owner, sealed in the open position, and inspected weekly as part of an approved procedure

**4.7.6.6** Where a pressure-reducing water deluge valve is used to control the discharge pressure, the set-pressure shall be recorded on a permanently marked weatherproof metal or rigid plastic sign secured with corrosion-resistant wire, chain, or other approved means.

**4.8 System Types.** The following four types of systems shall be permitted:

- (1) Fixed
- (2) Semifixed
- (3) Mobile
- (4) Portable

#### **4.9 Operation and Control of Systems.**

##### **4.9.1 Methods of Actuation.**

**4.9.1.1** Systems shall be permitted to be actuated automatically or manually.

**4.9.1.2** All systems shall have provisions for manual actuation.

##### **4.9.2 Automatically Actuated Systems.**

**4.9.2.1** An automatic system shall be activated by automatic detection equipment.

**4.9.2.2** Where operation is automatic, a reliable source of energy shall be used.

**4.9.2.3** The need for an alternate power supply shall be determined by the AHJ.

#### **4.9.2.4\* Automatic Detection Equipment.**

**4.9.2.4.1** Automatic detection equipment — whether pneumatic, hydraulic, or electric — shall be provided with supervision arranged so that failure of equipment or loss of supervising air pressure or loss of electric energy results in positive notification of the abnormal condition.

**4.9.2.4.2** Where approved by the AHJ, small systems for localized hazards shall be permitted to be unsupervised.

**4.9.2.5\*** Electric automatic detection equipment and any auxiliary electric equipment, if in hazardous areas, shall be designed expressly for use in such areas.

**4.9.2.6** The system shall be permitted to be arranged to shut off automatically after a predetermined operating time.

**4.9.2.6.1** Automatic shutdown and the predetermined operating time shall be approved by the AHJ.

**4.9.2.6.2** Where automatic shutdown is required, an alarm condition shall remain until manually reset.

#### **4.9.2.7 Detection System.**

**4.9.2.7.1** The detection system shall activate a local alarm as well as an alarm at a constantly attended location.

**4.9.2.7.2** The detection system's alarms also shall be actuated when the system is operated manually.

#### **4.9.3 Manually Actuated Systems.**

**4.9.3.1** Controls for manually actuated systems shall be located in a place removed from the hazard zone to permit them to be operated in an emergency, yet close enough to ensure operator knowledge of fire conditions.

**4.9.3.2** The location and purposes of the controls shall be indicated and shall be related to the operating instructions.

#### **4.9.4 Equipment.**

**4.9.4.1** All operating devices shall be designed for the service conditions they encounter.

**4.9.4.2** Operating devices shall not be rendered inoperative, or be susceptible to inadvertent operation, by environmental factors such as high or low temperature, atmospheric humidity or pollution, or marine conditions.

**4.9.4.3** Operating device systems shall have means for manual actuation.

### **Chapter 5 Low-Expansion Foam Tank, Fueling, and Spill Area Systems**

**5.1\* Types of Hazards.** This chapter shall cover design information for the use of low-expansion foam to protect outdoor storage tanks, interior flammable liquid hazards, loading racks, diked areas, and nondiked spill areas.

**5.2\* Outdoor Fixed-Roof (Cone) Tanks.** The following methods for protecting exterior fixed-roof tanks shall be included

within this section and shall not be considered to be in any order of preference:

- (1) Foam monitors and handlines, including those supplied by compressed air foam generation technology
- (2) Surface application with fixed foam discharge outlets, including those supplied by compressed air foam generation technology
- (3) Subsurface application
- (4) Semisubsurface injection methods

**5.2.1 Supplementary Protection.** In addition to the primary means of protection, supplementary protection shall be provided in accordance with the requirements found in Section 5.9.

**5.2.2 Basis of Design.** System design shall be based on protecting the tank requiring the largest foam solution flow, including supplementary hose streams.

**5.2.3\* Limitations.** Fixed outlets shall not be used to protect horizontal or pressure tanks.

#### **5.2.4 Design Criteria for Foam Monitors and Handlines.**

##### **5.2.4.1 Limitations.**

**5.2.4.1.1\*** Monitor nozzles shall be permitted to be used as the primary means of protection for cone roof tanks when part of a portable, mobile, or semi-fixed system (adequate fire water delivery, foam concentrate supply, and portable or fixed foam monitors), which can be put in service within 4 hours to protect the cone roof tank when the following requirements are met:

- (1) Risk assessment completed
- (2) Pre-incident contingency plan completed
- (3) Where approved by the AHJ

**5.2.4.1.2** Foam handlines shall not be permitted to be used as the primary means of protection for fixed-roof tanks over 30 ft (9 m) in diameter or those over 20 ft (6.1 m) in height.

##### **5.2.4.2 Foam Application Rates.**

###### **5.2.4.2.1\* Flow Considerations.**

**5.2.4.2.1.1** To determine actual solution flow requirements, consideration shall be given to potential foam losses from wind, and other factors shall be included in the calculations.

**5.2.4.2.1.2** A factor of 1.5 additional foam application rate shall be used as a minimum to compensate for these factors.

**5.2.4.2.2\*** The design parameters for the use of monitors and handline nozzles to protect tanks containing hydrocarbons shall be in accordance with Table 5.2.4.2.2.

###### **5.2.4.3\* Tanks Containing Flammable and Combustible Liquids Requiring Alcohol-Resistant Foams.**

**5.2.4.3.1\*** Water-soluble and certain flammable and combustible liquids and polar solvents that are destructive to regular (non-alcohol-resistant) foams shall use alcohol-resistant foams.

**5.2.4.3.2\*** For liquids in depths greater than 1 in. (25 mm), monitor and foam hose streams shall be limited for use with special alcohol-resistant foams listed and/or approved for the purpose.

**Table 5.2.4.2.2 Foam Handline and Monitor Protection for Fixed-Roof Storage Tanks Containing Hydrocarbons**

Hydrocarbon Type	Minimum Application Rate		Minimum Discharge Time (minutes)
	gpm/ft <sup>2</sup>	mm/min <sup>a</sup>	
Flash point between 100°F and 140°F (38°C and 60°C)	0.16	6.5	50
Flash point below 100°F (38°C) or liquids heated above their flash points	0.16	6.5	65
Crude petroleum	0.16	6.5	65

**Notes:**

(1) Included in this table are gasohols and unleaded gasolines containing no more than 10 percent oxygenated additives by volume. Where oxygenated additives content exceeds 10 percent by volume, protection is normally in accordance with 5.2.4.3. Certain nonalcohol-resistant foams might be suitable for use with fuels containing oxygenated additives of more than 10 percent by volume. The manufacturer should be consulted for specific listings or approvals.

(2) Flammable liquids having a boiling point of less than 100°F (38°C) might require higher rates of application. Suitable rates of application should be determined by test. Flammable liquids with a wide range of boiling points might develop a heat layer after prolonged burning and then can require application rates of 0.2 gpm/ft<sup>2</sup> (8.2 mm/min) or more.

(3) Care should be taken in applying portable foam streams to high-viscosity materials heated above 200°F (93°C). Good judgment should be used in applying foam to tanks containing hot oils, burning asphalts, or burning liquids that have a boiling point above the boiling point of water. Although the comparatively low water content of foams can beneficially cool such fuels at a slow rate, it can also cause violent frothing and "slop-over" of the tank's contents.

(4) Testing by the LASTFIRE Group has confirmed that the use of compressed air foam delivery systems can extinguish tank fires using monitors, handlines, and fixed foam application appliances. The results of testing by listing agencies, other third-party research testing organizations, or manufacturer's data should be used to determine application rates for this type of hydrocarbon fire control.

(5) When using SFFF, the user should refer to Annex H and the manufacturer's recommendations to determine application rates.

<sup>a</sup> L/min-m<sup>2</sup> is equivalent to mm/min.

**5.2.4.3.3** In all cases, the manufacturer of the foam concentrate and the foam-making equipment shall be consulted as to limitations and for recommendations based on listings or specific fire tests.

**5.2.4.4\*** **Design Parameters.** Where monitors and handline nozzles are used to protect tanks containing flammable and combustible liquids requiring alcohol-resistant foams, the operation time shall be 65 minutes at listed application rates, unless the foam manufacturer has established, by fire test, that a shorter time shall be permitted.

### **5.2.5 Design Criteria for Surface Application with Fixed Foam Discharge Outlets.**

#### **5.2.5.1\* Fixed Foam Discharge Outlets.**

**5.2.5.1.1** For the protection of a flammable liquid contained in a vertical fixed-roof (cone) atmospheric storage tank, discharge outlets shall be attached to the tank.

**5.2.5.1.2** Where two or more discharge outlets are required, the outlets shall be spaced equally around the tank periphery.

**5.2.5.1.2.1** Such outlets shall be individually piped and separately valved for isolation outside the dike area in accordance with 10.5.1.

**5.2.5.1.2.2** Each outlet shall be sized to deliver foam at the minimum application rate or higher.

**5.2.5.1.3** Fixed foam discharge outlets shall be attached at the top of the shell and shall be located or connected to preclude the possibility of the tank contents overflowing into the foam lines.

**5.2.5.1.4** Fixed foam discharge outlets shall be attached so that displacement of the roof will not subject them to damage.

**5.2.5.1.5** Fixed foam discharge outlets shall be provided with seal, frangible under low pressure, to prevent entrance of vapors into foam outlets and pipelines.

**5.2.5.1.6** Fixed foam discharge outlets shall be provided with inspection means to allow maintenance and for inspection and replacement of vapor seals.

#### **5.2.5.2 Design Criteria for Tanks Containing Hydrocarbons.**

**5.2.5.2.1\*** Fixed-roof (cone) tanks shall be provided with approved fixed foam discharge outlets as indicated in Table 5.2.5.2.1.

**5.2.5.2.2\* Minimum Discharge Times and Application Rates.** Where fixed foam discharge outlets are used for fixed-roof (cone) tanks containing hydrocarbons, the minimum discharge times and application rates shall be in accordance with Table 5.2.5.2.2.

**Table 5.2.5.2.1 Number of Fixed Foam Discharge Outlets for Fixed-Roof Tanks Containing Hydrocarbons or Flammable and Combustible Liquids Requiring Alcohol-Resistant Foams**

Tank Diameter (or Equivalent Area)		Minimum Number of Discharge Outlets
ft	m	
Up to 80	Up to 24	1
Over 80 to 120	Over 24 to 37	2
Over 120 to 140	Over 37 to 43	3
Over 140 to 160	Over 43 to 49	4
Over 160 to 180	Over 49 to 55	5
Over 180 to 200	Over 55 to 61	6
Over 200	Over 61	6
		Plus 1 outlet for each additional 5000 ft <sup>2</sup> (465 m <sup>2</sup> )

5.2.5.2.3 If the apparatus available has a delivery rate higher than 0.1 gpm/ft<sup>2</sup> (4.1 mm/min), a proportionate reduction in the time figure shall be permitted to be made, provided that the time is not less than 70 percent of the minimum discharge times shown.

#### 5.2.5.3\* Design Criteria for Tanks Containing Flammable and Combustible Liquids Requiring Alcohol-Resistant Foams.

5.2.5.3.1 Water-soluble and certain flammable and combustible liquids and polar solvents that are destructive to nonalcohol-resistant foams shall require the use of alcohol-resistant foams.

5.2.5.3.2\* In all cases, the manufacturers of the foam concentrate and the foam-making equipment shall be consulted as to limitations and for recommendations based on listings or specific fire tests.

5.2.5.3.3 Fixed-roof (cone) tanks shall be provided with approved fixed foam discharge outlets as indicated in Table 5.2.5.2.1.

5.2.5.3.4 **Minimum Discharge Times and Application Rates.** Minimum discharge times and application rates for fixed-roof (cone) tanks containing flammable and combustible liquids requiring alcohol-resistant foams shall be in accordance with Table 5.2.5.3.4.

**Table 5.2.5.2.2 Minimum Discharge Times and Application Rates for Type II Fixed Foam Discharge Outlets on Fixed-Roof (Cone) Storage Tanks Containing Hydrocarbons**

Hydrocarbon Type	Minimum Application Rate		Minimum Discharge Time (minutes)
	gpm/ft <sup>2</sup>	mm/min*	
Flash point between 100°F and 140°F (38°C and 60°C)	0.10	4.1	30
Flash point below 100°F (38°C) or liquids heated above their flash points	0.10	4.1	55
Crude petroleum	0.10	4.1	55

#### Notes:

(1) Included in this table are gasohols and unleaded gasolines containing no more than 10 percent oxygenated additives by volume. Where oxygenated additives content exceeds 10 percent by volume, protection is normally in accordance with 5.2.5.3. Certain nonalcohol-resistant foams might be suitable for use with fuels containing oxygenated additives of more than 10 percent by volume. Consult manufacturer for specific listings or approvals.

(2) Flammable liquids having a boiling point of less than 100°F (38°C) might require higher rates of application. Suitable rates of application should be determined by test.

(3) For high-viscosity liquids heated above 200°F (93°C), lower initial rates of application might be desirable to minimize frothing and expulsion of the stored liquid. Good judgment should be used in applying foams to tanks containing hot oils, burning asphalts, or burning liquids that have boiling points above the boiling point of water. Although the comparatively low water content of foams can beneficially cool such liquids at a slow rate, it can also cause violent frothing and "slop-over" of the tank's contents.

(4) Type I discharge outlets are considered obsolete, and those currently installed become Type II outlets if damaged. Refer to A.5.2.5.2.2 for additional information and minimum discharge times for existing Type I outlets.

(5) Testing by the LASTFIRE Group has confirmed that the use of compressed air foam delivery systems can extinguish tank fires using monitors, handlines, and fixed foam application appliances. The results of testing by listing agencies, other third-party research testing organizations, or manufacturer's data should be used to determine application rates for this type of hydrocarbon fire control.

(6) When using SFFF, the user should refer to Annex H and the manufacturer's recommendations to determine application rates.

\*L/min-m<sup>2</sup> is equivalent to mm/min.

**Table 5.2.5.3.4 Minimum Application Rates and Discharge Times for Fixed-Roof (Cone) Tanks Containing Flammable and Combustible Liquids Requiring Alcohol-Resistant Foams**

Application Rate for Specific Product Stored	Minimum Discharge Time (minutes)
	Type II Foam Discharge Outlet
Consult manufacturer for listings on specific products	55

**Notes:**

(1) Most currently manufactured alcohol-resistant foams are suitable for use with Type II fixed foam discharge outlets. However, some older alcohol-resistant foams require gentle surface application by Type I fixed foam discharge outlets. Consult manufacturers for listings on specific products.

(2) Type I discharge outlets are considered obsolete, and those currently installed become Type II outlets if damaged. Refer to A.5.2.5.2.2 for additional information and minimum discharge times for existing Type I outlets.

**5.2.6 Design Criteria for Subsurface Application.**

**5.2.6.1\*** Subsurface foam injection systems shall be permitted for protection of liquid hydrocarbons in vertical fixed-roof atmospheric storage tanks.

**5.2.6.1.1** Subsurface injection systems shall not be used for protection of Class IA hydrocarbon liquids or for the protection of alcohols, esters, ketones, aldehydes, anhydrides, or other products requiring the use of alcohol-resistant foams.

**5.2.6.1.2\*** Foam concentrates and equipment for subsurface injection shall be listed for this purpose.

**5.2.6.2\* Foam Discharge Outlets.**

**5.2.6.2.1** The discharge outlet into the tank shall be permitted to be the open end of a foam delivery line or product line.

**5.2.6.2.2** Outlets shall be sized so that foam generator discharge pressure and foam velocity limitations are not exceeded.

**5.2.6.2.3** The foam velocity at the point of discharge into the tank contents shall not exceed 10 ft/sec (3 m/sec) for Class IB liquids or 20 ft/sec (6 m/sec) for other classes of liquids unless actual tests prove that higher velocities are satisfactory.

**5.2.6.2.4\*** Where two or more outlets are required, they shall be located so that the foam travel on the surface cannot exceed 100 ft (30 m).

**5.2.6.2.5** Each outlet shall be sized to deliver foam at the minimum application rate or higher.

**5.2.6.2.6** For even foam distribution, outlets shall be permitted to be shell connections or shall be permitted to be fed through a pipe manifold within the tank from a single shell connection.

**5.2.6.2.7** Rather than installing additional tank nozzles, shell connections shall be permitted to be made in manway covers.

**5.2.6.2.8** Tanks shall be provided with subsurface foam discharge outlets as shown in Table 5.2.6.2.8.

**5.2.6.3\* Foam Discharge Outlet Elevation.**

**5.2.6.3.1\*** Foam discharge outlets shall be located so as not to discharge into a water bottom.

**Table 5.2.6.2.8 Minimum Number of Subsurface Foam Discharge Outlets for Fixed-Roof Tanks Containing Hydrocarbons**

Tank Diameter		Minimum Number of Discharge Outlets	
ft	m	Flash Point Below 100°F (38°C)	Flash Point 100°F (38°C) or Higher
Up to 80	Up to 24	1	1
Over 80 to 120	Over 24 to 37	2	1
Over 120 to 140	Over 37 to 43	3	2
Over 140 to 160	Over 43 to 49	4	2
Over 160 to 180	Over 49 to 55	5	2
Over 180 to 200	Over 55 to 61	6	3
Over 200	Over 61	6	3
		Plus 1 outlet for each additional 5000 ft <sup>2</sup> (465 m <sup>2</sup> )	Plus 1 outlet for each additional 7500 ft <sup>2</sup> (700 m <sup>2</sup> )

**Notes:**

(1) For Class IA liquids, see 5.2.6.1.1.

(2) Table 5.2.6.2.8 is based on extrapolation of fire test data on 25 ft (7.6 m), 93 ft (28 m), and 115 ft (35 m) diameter tanks containing gasoline, crude oil, and hexane, respectively.

(3) The most viscous fuel that has been extinguished by subsurface injection where stored at ambient conditions [60°F (16°C)] had a viscosity of 440 centistokes (2000 SSU) and a pour point of 15°F (-9°C). Subsurface injection of foam generally is not recommended for fuels that have a viscosity greater than 440 centistokes (2000 SSU) at their minimum anticipated storage temperature.

(4) In addition to the control provided by the smothering effect of the foam and the cooling effect of the water in the foam that reaches the surface, fire control and extinguishment can be enhanced further by the rolling of cool product to the surface.



**5.2.6.3.2** The requirement of 5.2.6.3.1 shall be accomplished by having the outlets located at least 12 in. (300 mm) above the highest water level to prevent destruction of the foam.

**5.2.6.4\* Subsurface Injection Back-Pressure Limitations.** The sizes and lengths of discharge pipe or lines used beyond the foam maker and the anticipated maximum depth of the fuel to be protected shall be such that the back pressure is within the range of pressures under which the device has been tested and listed by testing laboratories.

**5.2.6.5 Minimum Discharge Times and Application Rates.**

**5.2.6.5.1** The minimum discharge times and application rates for subsurface application on fixed-roof storage tanks shall be in accordance with Table 5.2.6.5.1.

**5.2.6.5.2\*** In cases where liquid hydrocarbons contain foam-destructive products, the manufacturer of the foam concentrate shall be consulted for recommendations based on listings and/or approvals.

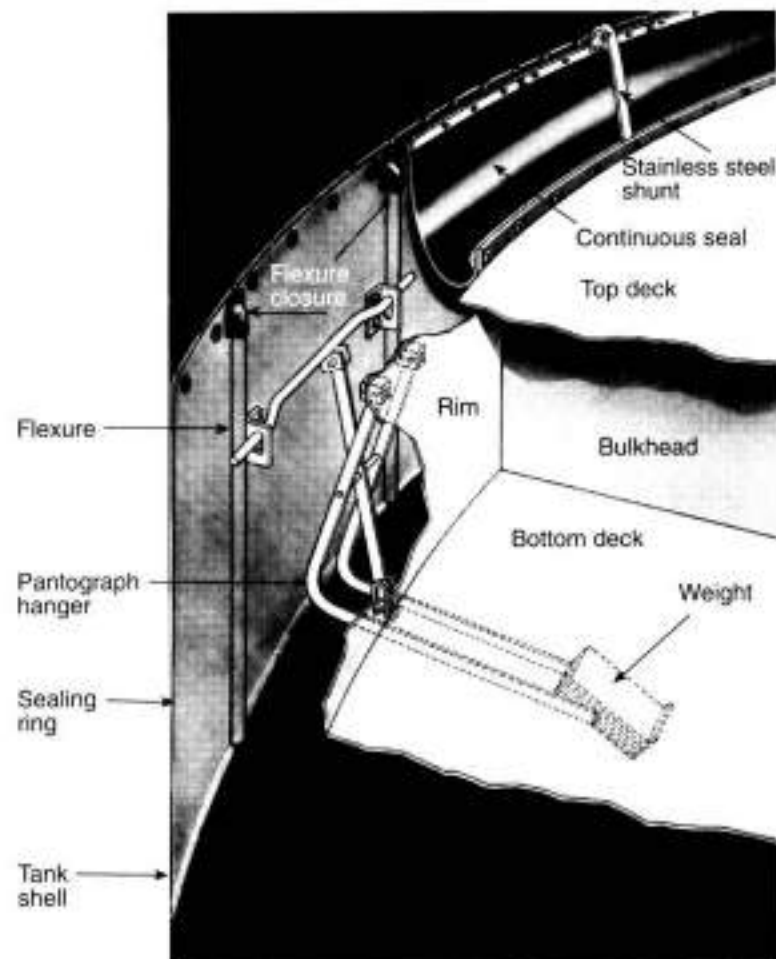
**5.2.6.5.3** If the apparatus available has a delivery rate higher than 0.1 gpm/ft<sup>2</sup> (4.1 mm/min), a proportionate reduction in the time figure shall be permitted to be made, provided that the time is not less than 70 percent of the minimum discharge time shown and that the maximum foam velocity is in accordance with 5.2.6.2.3.

**5.2.7\* Semisubsurface Systems.** All equipment used in semi-subsurface systems shall be listed or approved for this purpose.

**5.3\* Outdoor Open-Top Floating Roof Tanks.** Outdoor open-top floating roof tanks shall be as illustrated in Figure 5.3(a) through Figure 5.3(d).

**5.3.1 Tank Protection Options.**

**5.3.1.1** Tanks shall be protected by seal area protection only (see 5.3.1.2) or by seal protection and full surface protection (see 5.3.1.3).



**FIGURE 5.3(a) Pantograph-Type Seal Open-Top Floating Roof Tank.**

**Table 5.2.6.5.1 Minimum Discharge Times and Application Rates for Subsurface Application on Fixed-Roof Storage Tanks**

Hydrocarbon Type	Minimum Application Rate		Minimum Discharge Time (minutes)
	gpm/ft <sup>2</sup>	mm/min*	
Flash point between 100°F and 140°F (38°C and 60°C)	0.1	4.1	30
Flash point below 100°F (38°C) or liquids heated above their flash points	0.1	4.1	55
Crude petroleum	0.1	4.1	55

Notes:

- (1) The maximum application rate shall be 0.20 gpm/ft<sup>2</sup> (8.1 mm/min).
- (2) For high-viscosity liquids heated above 200°F (93°C), lower initial rates of application might be desirable to minimize frothing and expulsion of the stored liquid. Good judgment should be used in applying foams to tanks containing hot oils, burning asphalts, or burning liquids that are heated above the boiling point of water. Although the comparatively low water content of foams can beneficially cool such liquids at a slow rate, it can also cause violent frothing and "slop-over" of the tank's contents.
- (3) When using SFFF, the user should refer to Annex H and the manufacturer's recommendations to determine application rates.

\*L/min-m<sup>2</sup> is equivalent to mm/min.

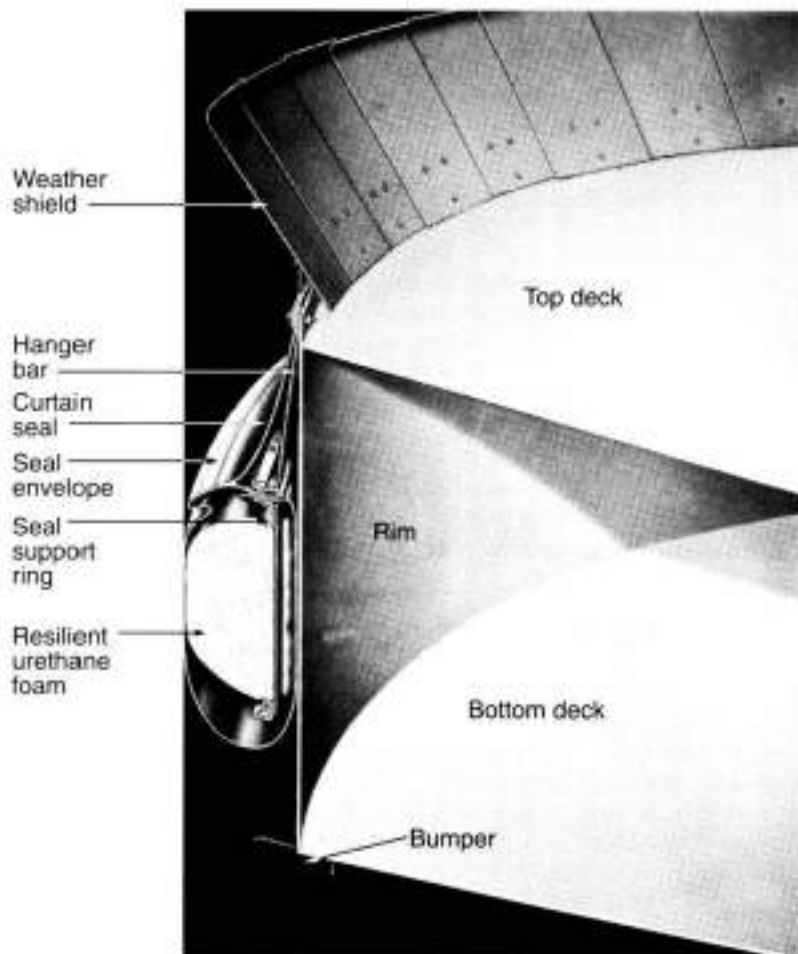


FIGURE 5.3(b) Tube Seal Open-Top Floating Roof Tank.

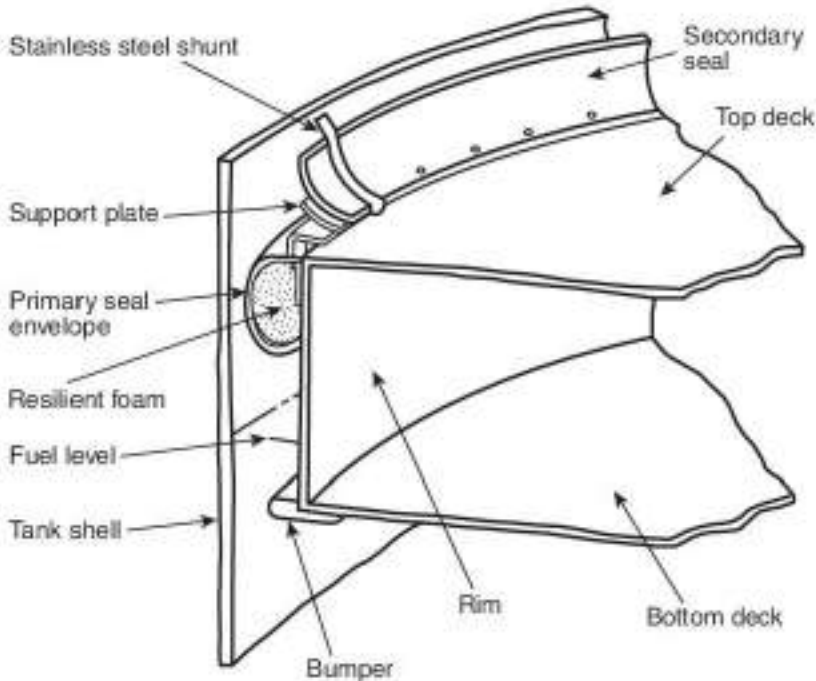


FIGURE 5.3(c) Double Seal System for Floating Roofs.

5.3.1.2 Seal area protection systems shall be permitted for the following types of roof construction:

- (1) Steel double deck
- (2) Steel pontoon
- (3)\* Other tank construction that has passed external tank construction testing

5.3.1.3 The following tank construction types shall be protected with both seal area and full surface protection due to the

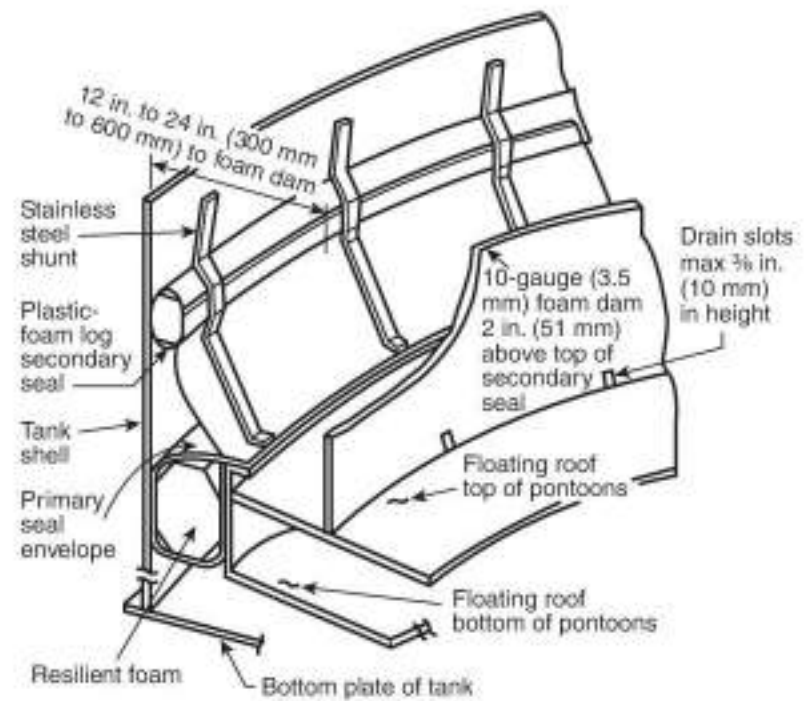


FIGURE 5.3(d) Double Seal System for Floating Roofs Using Plastic-Foam Log (Secondary Seal).

higher probability that the floating roof will be damaged and sink in a fire:

- (1) Roofs made from floating diaphragms
- (2) Roofs that rely on flotation device closures that are easily submerged if damaged
- (3) Pan roofs

5.3.1.4 Tanks equipped with the following floating roof types shall not be covered in Section 5.3:

- (1) Roofs made from floating diaphragms
- (2) Roofs that rely on flotation device closures that are easily submerged if damaged
- (3) Pan roofs

5.3.2 Systems for tanks so equipped shall be designed in accordance with 5.4.2.2.

#### 5.3.3\* Types of Fires Anticipated.

5.3.3.1 Subsurface and Semisubsurface Injection. Subsurface and semisubsurface injection shall not be used for protection of open-top or covered floating roof tanks because of the possibility of improper distribution of foam at the fuel surface caused by the floating roof, even if partially submerged.

5.3.3.2 Seal Area Protection. The foam protection facilities for an open-top floating roof tank seal area shall be based on 5.3.2 through 5.3.5.

#### 5.3.4 Methods of Seal Fire Protection.

5.3.4.1 The following methods for fire protection of seals in open-top floating roof tanks shall be as required in 5.3.5 through 5.3.7:

- (1) Fixed discharge outlets
- (2) Foam handlines
- (3)\* Small portable monitors [500 gpm (1900 L/min) or less] from the top platform

**5.3.4.2 Supplementary Protection.** In addition to the primary means of protection, supplementary protection shall be provided in accordance with the requirements of Section 5.9.

**5.3.4.3\* Basis of Design.** System design shall be based on protecting the tank requiring the largest foam solution flow, including supplementary hose streams.

**5.3.5 Fixed Discharge Outlets Design Criteria for Seal Area Protection.**

**5.3.5.1** Application of foam from fixed discharge outlets shall be permitted to be achieved by either of the following two methods:

- (1) The first method discharges foam above the mechanical shoe seal, a metal weather shield, or a secondary seal.
- (2) The second method discharges foam below a mechanical shoe seal directly onto the flammable liquid, behind a metal weather shield directly onto the tube seal envelope, or beneath a secondary seal onto the primary seal.

**5.3.5.2\* Top-of-Seal Method with Foam Dam.**

**5.3.5.2.1** Fixed foam discharge outlets located above a mechanical shoe seal, above a tube seal weather shield, or above a secondary seal shall be used in conjunction with a foam dam.

**5.3.5.2.2** The following shall be permitted to be two methods of application of fixed foam discharge outlets:

- (1) Fixed foam discharge outlets (normally Type II) mounted above the top of the tank shell
- (2) Fixed foam discharge outlets mounted on the periphery of the floating roof

**5.3.5.2.3\*** For this application, the fixed foam discharge outlets shall not be fitted with a frangible vapor seal device.

**5.3.5.3 Top-of-Seal System Design.**

**5.3.5.3.1** The design parameters for the application of fixed foam discharge outlets on top of the seal to protect open-top floating roof tanks shall be in accordance with Table 5.3.5.3.1 and Figure 5.3.5.3.1.

**5.3.5.3.2** The requirements specified in Table 5.3.5.3.1 apply to tanks containing hydrocarbons or flammable and combustible materials requiring alcohol-resistant foams.

**5.3.5.3.3** The required minimum application rates specified in Table 5.3.5.3.1 shall apply, unless listings for specific products require higher application rates where Type II fixed foam discharge outlets are used.

**5.3.5.3.4** If the application rate is higher than the minimum rate specified in Table 5.3.5.3.1, the discharge time shall be permitted to be reduced proportionately, provided that the reduced time is not less than 70 percent of the minimum discharge times specified.

**5.3.5.3.5 Below Primary Seal or Weather Shield Method.**

**5.3.5.3.5.1** Fixed foam discharge outlets located below either a mechanical shoe seal, a metal weather shield, or a metal secondary seal shall use the designs that are illustrated in Figure 5.3.5.3.5.1.

**5.3.5.3.5.2** A foam dam shall be installed if a tube seal is used and the top of the tube seal is less than 6 in. (152 mm) below the top of the pontoon.

**5.3.5.3.6 Below-the-Seal or Weather Shield System.**

**5.3.5.3.6.1** The design parameters for the application of fixed foam discharge outlets below the seal (or weather shield) to protect open-top floating roof tanks shall be in accordance with Table 5.3.5.3.6.1.

**5.3.5.3.6.2** The requirements shown in Table 5.3.5.3.6.1 shall apply to tanks containing hydrocarbons or flammable and combustible materials requiring alcohol-resistant foams.

**5.3.5.3.6.3** The required minimum application rates shown in Table 5.3.5.3.6.1 shall apply unless listings for specific products require higher application rates when Type II fixed foam discharge outlets are used.

**5.3.5.3.6.4** Below-the-seal (or shield) application shall not be used with combustible secondary seals.

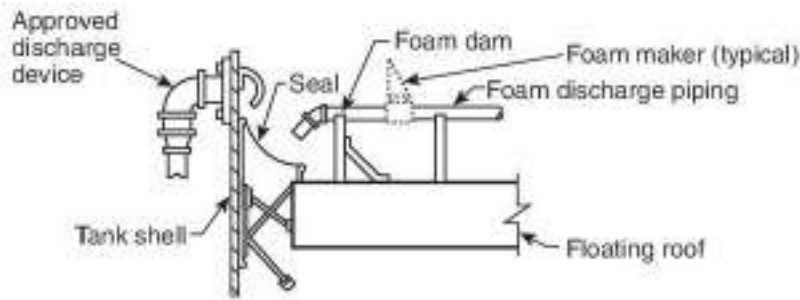
**Table 5.3.5.3.1 Top-of-Seal Fixed Foam Discharge Protection for Open-Top and Internal Floating Roof Tanks**

	Applicable Illustration Detail	Minimum Application Rate		Minimum Discharge Time (minutes)	Maximum Spacing Between Discharge Outlets with			
					12 in. (305 mm) Foam Dam		24 in. (600 mm) Foam Dam	
					gpm/ft <sup>2</sup>	mm/min*	ft	m
Mechanical shoe seal	A	0.3	12.2	20	40	12	80	24
Tube seal with metal weather shield	B	0.3	12.2	20	40	12	80	24
Fully or partly combustible secondary seal	C	0.3	12.2	20	40	12	80	24
All metal secondary seal	D	0.3	12.2	20	40	12	80	24

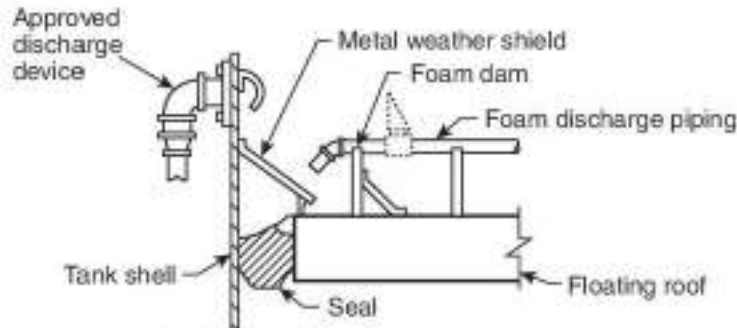
Notes:

- (1) Where the fixed foam discharge outlets are mounted above the top of the tank shell, a foam splashboard is necessary due to the effect of winds.
- (2) When using SFFF, the user should refer to Annex H and the manufacturer's recommendations to determine application rates.

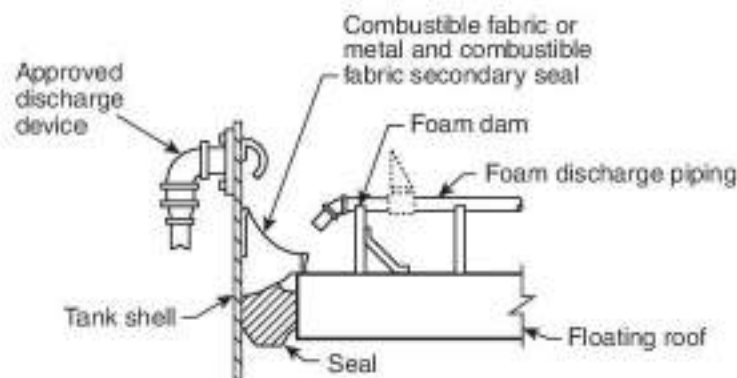
\*L/min-m<sup>2</sup> is equivalent to mm/min.



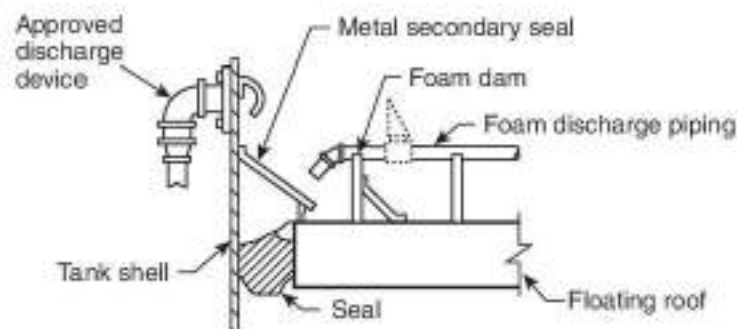
**DETAIL A** — Top-of-seal application  
Foam discharge above mechanical shoe seal



**DETAIL B** — Top-of-seal application  
Foam discharge above metal weather seal

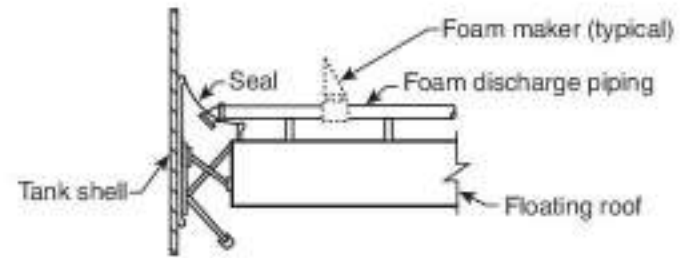


**DETAIL C** — Top-of-seal application  
Foam discharge above secondary combustible fabric seal, or metal with combustible fabric sections

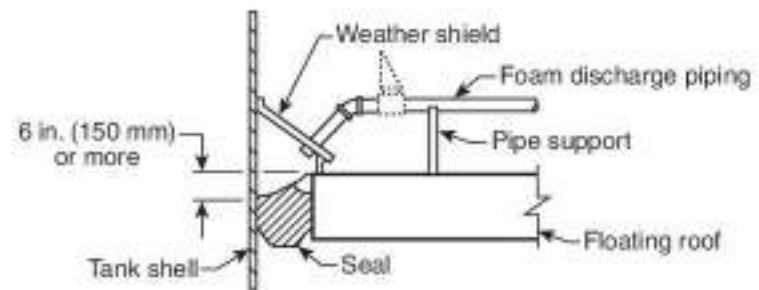


**DETAIL D** — Top-of-seal application  
Foam discharge above metal secondary seal

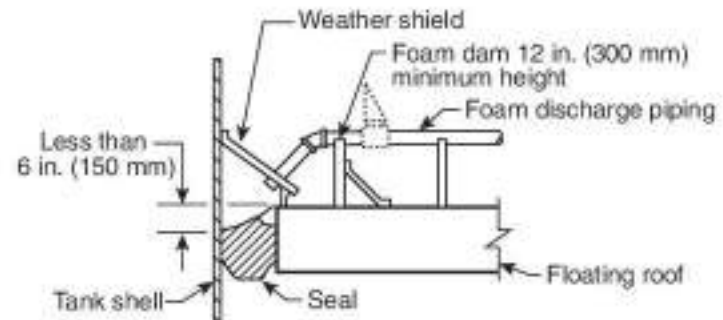
**FIGURE 5.3.5.3.1** Typical Foam System Illustrations for Top-of-Seal Fire Protection. Both fixed foam (wall-mounted) and roof-mounted discharge outlets are shown for illustrative purposes. Although both methods are shown, only one is needed.



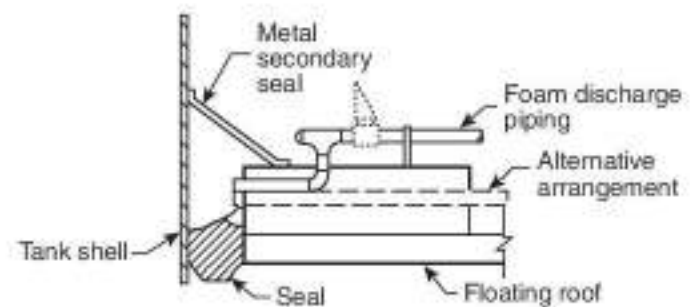
**DETAIL A** — Below-the-seal application  
Foam discharge below mechanical shoe seal — no foam dam



**DETAIL B** — Below-the-shield application  
Foam discharge below metal weather shield  
Top of seal 6 in. (150 mm) or more below top of floating roof



**DETAIL C** — Below-the-shield application  
Foam discharge below metal weather shield  
Top of seal less than 6 in. (150 mm) below top of floating roof



**DETAIL D** — Below-the-seal application  
Foam discharge below metal secondary seal  
This foam application method is not acceptable if secondary seal is constructed of any combustible fabric sections.  
(Refer to application above seal.)

**FIGURE 5.3.5.3.5.1** Typical Foam System Arrangement Illustrations for Below-the-Seal (or Shield) Application.

**Table 5.3.5.3.6.1 Below-the-Seal Fixed Foam Discharge Protection for Open-Top Floating Roof Tanks**

Seal Type	Applicable Illustration Detail	Minimum Application Rate		Minimum Discharge Time (minutes)	Maximum Spacing Between Discharge Outlets
		gpm/ft <sup>2</sup>	mm/min*		
Mechanical shoe seal	A	0.5	20.4	10	130 ft (40 m) — Foam dam not required
Tube seal with more than 6 in. (150 mm) between top of tube and top of pontoon	B	0.5	20.4	10	60 ft (18 m) — Foam dam not required
Tube seal with less than 6 in. (150 mm) between top of tube and top of pontoon	C	0.5	20.4	10	60 ft (18 m) — Foam dam required
Tube seal with foam discharge below metal secondary seal†	D	0.5	20.4	10	60 ft (18 m) — Foam dam not required

\*L/min·m<sup>2</sup> is equivalent to mm/min.

†A metal secondary seal is equivalent to a foam dam.

**5.3.5.4 Foam Dam Design Criteria.**

**5.3.5.4.1** The foam dam shall be circular and constructed of at least No. 10 U.S. standard gauge thickness [0.134 in. (3.4 mm)] steel plate.

**5.3.5.4.2** The foam dam shall be welded or otherwise fastened to the floating roof.

**5.3.5.4.3** The foam dam shall be designed to retain foam at the seal area, at a depth to cover the seal area while causing the foam to flow laterally to the point of seal rupture.

**5.3.5.4.3.1** Dam height shall be at least 12 in. (300 mm) as measured from the connection between the seal and the roof.

**5.3.5.4.3.2** The dam shall extend at least 2 in. (50 mm) above a metal secondary seal or a combustible secondary seal using a plastic-foam log.

**5.3.5.4.3.3** Dam height shall be at least 2 in. (50 mm) higher than any burnout panels in metal secondary seals.

**5.3.5.4.4** The foam dam shall be at least 12 in. (300 mm), but not more than 24 in. (600 mm), from the tank shell.

**5.3.5.4.5\*** To allow drainage of rainwater, the foam dam bottom shall be slotted on the basis of 0.04 in<sup>2</sup> of slot area per ft<sup>2</sup> of dammed area (278 mm<sup>2</sup> of slot area per m<sup>2</sup> of dammed area), restricting drain slots to a maximum 3/8 in. (10 mm) in height, as shown in Figure 5.3.5.4.5.

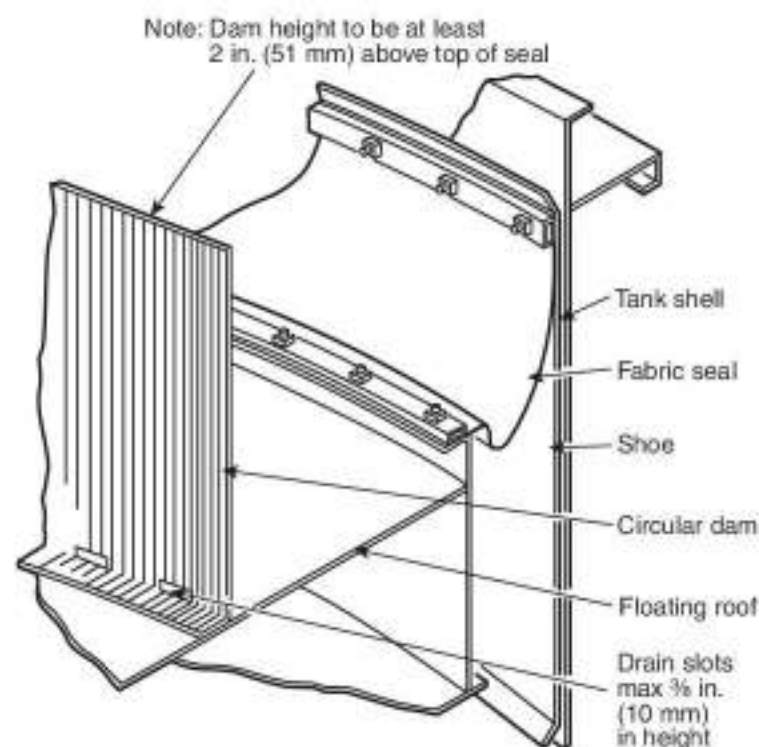
**5.3.6\* Foam Handline Design Criteria for Seal Area Protection.**

**5.3.6.1** Foam handlines shall be permitted to be used from the wind girder for extinguishment of seal fires in open-top floating roof tanks.

**5.3.6.2** Listed or approved equipment shall be used.

**5.3.7 Foam Monitor Design Criteria for Seal Area Protection.**

Monitors shall not be used as the primary means of floating roof seal fire extinguishment because of the difficulty of directing foam into the annular space and the possibility of sinking the roof.

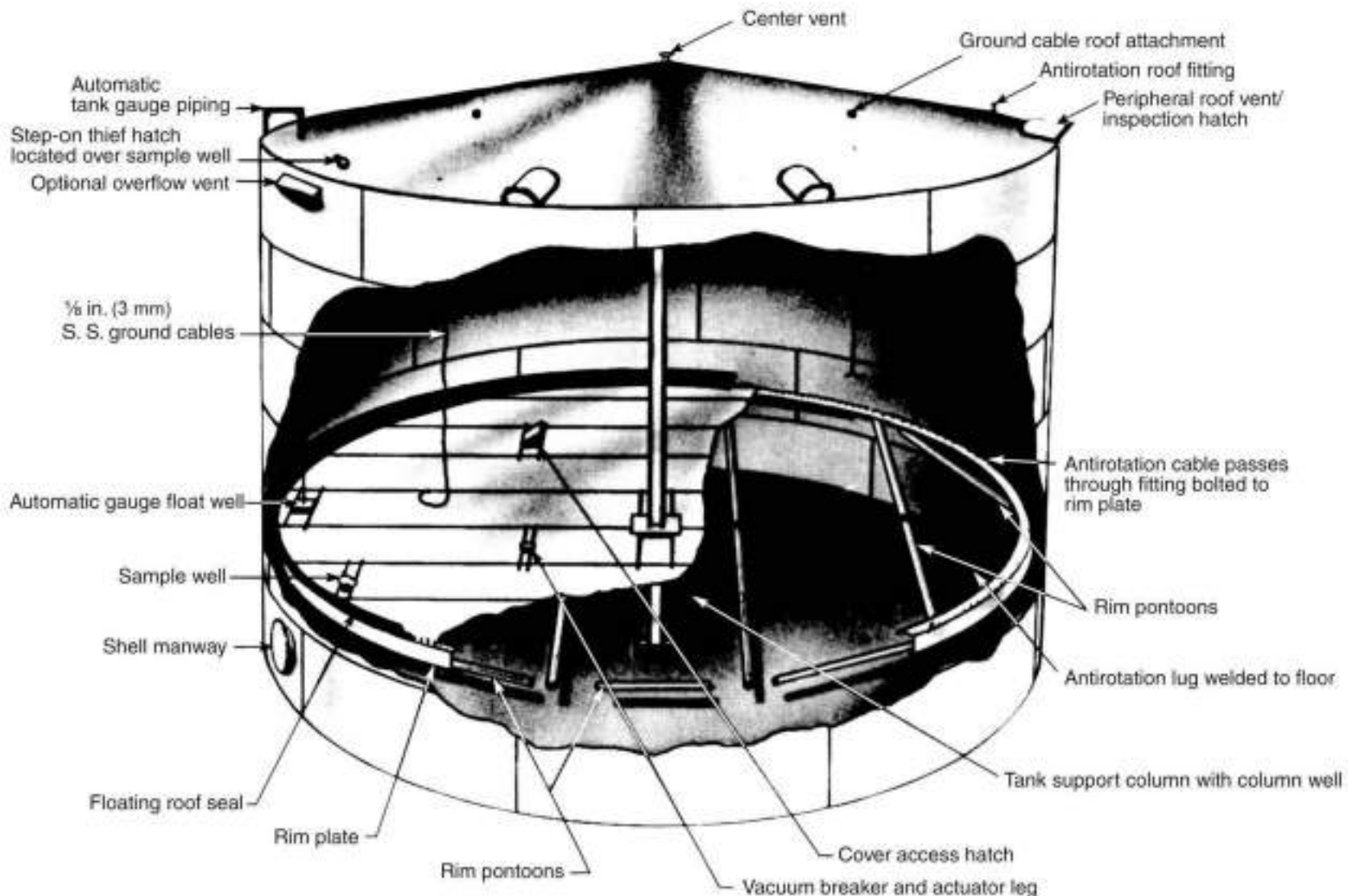


**FIGURE 5.3.5.4.5 Typical Foam Dam for Floating Roof Tank Protection.**

**5.4\* Outdoor Covered (Internal) Floating Roof Tanks.** See Figure 5.4.

Requirements for tanks equipped with the following floating roof types shall not be covered in Section 5.4:

- (1) Roofs made from floating diaphragms
- (2) Roofs made from plastic blankets
- (3) Roofs made with plastic or other flotation material, even if encapsulated in metal or fiberglass, except as permitted in 5.4.2
- (4) Roofs that rely on flotation device closures that are easily submerged if damaged
- (5) Pan roofs



**FIGURE 5.4** Typical Covered Floating Roof Tank.

**5.4.2\*** Seal area protection systems shall be permitted for the following types of roof construction:

- (1) Steel double deck
- (2) Steel pontoon
- (3) Full liquid surface contact, metallic sandwich panel, conforming to Appendix H, "Internal Floating Roofs," requirements of API STD 650
- (4)\* Full liquid surface contact, composite sandwich roof/seal system, designed in accordance with the performance criteria in Appendix H, "Internal Floating Roofs," requirements of API STD 650 and the following:
  - (a) Fiberglass components shall be made from high-grade vinyl ester resin with a corrosion-resistant bottom surface and be compatible with the stored product.
  - (b) The top layer shall exhibit a flame spread index not exceeding 25 when tested in accordance with ASTM E84 (Class A).
  - (c) The structural laminate of the composite sandwich structure shall be in accordance with ASTM C582.
  - (d) Core material shall be of a closed-cell structure for inherent redundant buoyancy and shall be chemically compatible with the stored product.
  - (e) The roof surfaces shall be a seamless, one-piece construction that utilizes chemical bonds to join all components.

- (f) The perimeter seal system shall be gas-tight and utilize noncombustible material to cover the rim space.

**5.4.2.1** All other types of roof construction shall require full surface protection.

**5.4.2.2 Design for Full Surface Fire.**

**5.4.2.2.1** Where the basis for design is a full surface fire, the covered (internal) floating roof tank shall be treated as equivalent to a fixed-roof (cone) tank of the same diameter for the purpose of foam system design.

**5.4.2.2.2** For a full surface fire, the foam facilities shall be designed in accordance with 5.2.5 and Section 5.9, except that separately valved laterals for each foam discharge shall not be required.

**5.4.2.2.3** For this application, fixed foam discharge outlets shall not be fitted with a frangible vapor seal device.

**5.4.2.2.4** Subsurface and semisubsurface injection shall not be used because of the possibility of improper distribution of foam.

**5.4.2.3 Design for Seal Area Fire.**

**5.4.2.3.1** Where the basis for design is a seal fire, the covered (internal) floating roof tank shall be treated as equivalent to an

open-top floating roof tank of the same diameter for the purpose of foam system design.

**5.4.2.3.2** For a seal fire, the foam discharge system shall be designed in accordance with the requirements specified in Table 5.3.5.3.1 utilizing fixed foam discharge outlets.

**5.4.2.3.3 Supplementary Protection.** In addition to the primary means of protection, there shall be provisions for supplementary protection in accordance with the requirements of Section 5.9.

**5.4.2.3.4\* Basis of Design.**

**5.4.2.3.4.1** System design shall be based on protecting the tank requiring the largest solution flow, including supplementary hose streams.

**5.4.2.3.4.2** If the application rate is higher than the minimum rate specified in Table 5.2.6.5.1, the discharge time shall be permitted to be reduced proportionately, but shall not be less than 70 percent of the minimum discharge times specified.

**5.5 Indoor Hazards.**

**5.5.1\*** This section shall address foam fire-extinguishing systems, which are intended to protect indoor storage tanks that have liquid surface areas of 400 ft<sup>2</sup> (37 m<sup>2</sup>) or greater.

**5.5.2 Discharge Outlets.** Tanks for storing liquid hydrocarbons shall be fitted with Type II, tank-mounted fixed foam discharge outlets as specified in Table 5.2.6.2.8.

**5.5.3 Minimum Discharge Time and Application Rate.**

**5.5.3.1** The minimum application rate for indoor hydrocarbon storage tanks shall be 0.16 gpm/ft<sup>2</sup> (6.5 mm/min) of liquid surface area.

**5.5.3.2** Minimum discharge time shall be as specified in Table 5.2.5.2.2 for Type II fixed foam discharge outlets.

**5.5.3.3** If the application rate is higher than the minimum rate specified in 5.5.2, the discharge time shall be permitted to be reduced proportionately, but not to less than 70 percent of the minimum discharge times indicated.

**5.5.4 Design Criteria for Indoor Storage Tanks Containing Flammable or Combustible Liquids Requiring Alcohol-Resistant Foams.**

**5.5.4.1\*** Water-soluble and certain flammable and combustible liquids and polar solvents that are destructive to nonalcohol-resistant foams shall require the use of alcohol-resistant foams.

**5.5.4.2** In all cases, the manufacturers of the foam concentrate and the foam-making equipment shall be consulted as to limitations and for recommendations based on listings or specific fire tests.

**5.6\* Loading Racks.**

**5.6.1** Within the scope of this standard, loading racks shall be defined as being either truck or rail car types for the purpose of loading or unloading product.

**5.6.2** Total rack size, flammable or combustible products involved, proximity of other hazards and exposures, drainage facilities, wind conditions, ambient temperatures, and available staff all shall be factored into the design of a loading rack foam system.

**5.6.3 Methods of Protection.** The following methods shall be permitted for protecting loading racks:

- (1) Foam-water sprinkler application utilizing air-aspirating foam-water sprinklers or nozzles or non-air-aspirating open standard sprinklers or foam nozzles using compressed air foam delivery systems
- (2) Foam monitors or foam monitors using compressed air foam delivery systems
- (3) Other devices approved by the AHJ

**5.6.4 Design Criteria for Foam-Water Sprinkler Systems.** The design criteria for sprinkler systems shall be in accordance with NFPA 16.

**5.6.5 Design Criteria for Foam Monitor Protection Systems.**

**5.6.5.1\* Areas to Be Protected by Monitor Nozzles.** Monitor nozzle system design shall be based on the total ground area within the curb.

**5.6.5.2** The intent of the design shall be to protect the canopy, pumps, meters, vehicles, and miscellaneous equipment associated with the loading and unloading operation in the event of a spill fire.

**5.6.5.3 Minimum Application Rates and Discharge Times.**

**5.6.5.3.1** Minimum foam application rates and discharge times for loading racks protected by monitor nozzles shall be as specified in Table 5.6.5.3.1.

**5.6.5.3.1.1** Foam types not included in Table 5.6.5.3.1 shall be permitted where used in accordance with their listing.

**5.6.5.3.2** If a fuel depth of more than 1 in. (25 mm) can accumulate within the protected area, the application rate shall be increased to 0.16 gpm/ft<sup>2</sup> (6.5 mm/min).

**Table 5.6.5.3.1 Minimum Application Rates and Discharge Times for Loading Racks Protected by Foam Monitor Nozzle Systems**

Foam Type	Minimum Application Rate		Minimum Discharge Time (minutes)	Product Being Loaded
	gpm/ft <sup>2</sup>	mm/min*		
Protein and fluoroprotein	0.16	6.5	15	Hydrocarbons
AFFF, FFFP, and alcohol-resistant AFFF or FFFP	0.10	4.1	15	Hydrocarbons
Alcohol-resistant foams	Consult manufacturer for listings on specific products		15	Flammable and combustible liquids requiring alcohol-resistant foam

\*L/min-m<sup>2</sup> is equivalent to mm/min.

### 5.7\* Diked Areas — Outdoor.

**5.7.1** For the purpose of this standard, diked areas shall be areas bounded by contours of land or physical barriers that retain a fuel to a depth greater than 1 in. (25 mm).

**5.7.2** Protection of these areas shall be achieved by either fixed discharge outlets, fixed or portable monitors, or foam hoses.

**5.7.3 Methods of Application.** Where foam protection is used for a diked area, it shall be permitted to be accomplished by any of the following methods:

- (1) Low-level foam discharge outlets
- (2) Foam monitors or foam hoses
- (3) Foam-water sprinklers or nozzles

**5.7.3.1** This list of methods shall not be considered as being in the order of preference.

**5.7.3.2\* Minimum Application Rates and Discharge Times for Fixed Discharge Outlets on Diked Areas Involving Liquid Hydrocarbons.** The minimum application rates and discharge times for fixed foam application on diked areas shall be as specified in Table 5.7.3.2.

#### 5.7.3.3\* Fixed Foam Discharge Outlets.

**5.7.3.3.1** Fixed foam discharge outlets shall be sized and located to apply foam uniformly over the dike area at the application rate specified in Table 5.7.3.2.

**5.7.3.3.2** Large dike areas shall be permitted to be subdivided to keep the total design solution within practical limits.

#### 5.7.3.4 Fixed Foam-Water Sprinklers or Nozzles.

**5.7.3.4.1** Where fixed foam-water sprinklers or nozzles are used, the system design shall be in accordance with NFPA 16.

**5.7.3.4.2\*** Where foam-water sprinklers or nozzles are used as the primary protection, the design shall include the possibility that some of the foam discharge will be carried by the wind beyond the area of the fuel spill.

#### 5.7.3.5 Fixed Low-Level Foam Discharge Outlets.

**5.7.3.5.1** Fixed low-level foam discharge outlets shall be permitted to be open pipe fittings or directional flow nozzles

designed to discharge a compact, low-velocity foam stream onto the inner wall of the dike or, where necessary, directly onto the dike floor.

**5.7.3.5.2** Fixed low-level foam discharge outlets shall be located around the dike wall, and, where necessary, inside the dike area, to apply foam uniformly over the dike area.

#### 5.7.3.5.3\* Limitations.

**5.7.3.5.3.1** Where fixed discharge outlets installed at a low level are used as the primary protection, they shall be located so that no point in the dike area is more than 30 ft (9 m) from a discharge outlet where the discharge per outlet is 60 gpm (230 L/min) or less.

**5.7.3.5.3.2** For outlets having discharge rates higher than 60 gpm (230 L/min), the maximum distance between discharge outlets shall be 60 ft (18 m).

**5.7.3.5.4 Foam Monitors.** Where monitors are used to discharge foam onto the dike area, they shall be located outside the dike area.

**5.7.3.5.4.1** Where foam monitors are used as the primary protection, the design shall include the possibility that some of the foam discharge will be carried by the wind beyond the area of the fuel spill.

**5.7.3.5.4.2** Where the monitor discharge is in the form of a compact, high-velocity foam stream, it shall be directed against the dike walls, tank surfaces, or other structures to prevent its plunging directly into the burning liquid surface.

#### 5.7.4 Diked Areas Involving Flammable or Combustible Liquids Requiring Alcohol-Resistant Foams.

**5.7.4.1** Water-soluble and certain flammable and combustible liquids and polar solvents that are destructive to nonalcohol-resistant foams shall require the use of alcohol-resistant foams.

**5.7.4.2** Systems using these foams shall require special engineering consideration.

**5.7.4.3** The design criteria for diked areas involving flammable or combustible liquids requiring alcohol-resistant foams shall be as stated in 5.7.4.3.1 through 5.7.4.3.3.

**Table 5.7.3.2 Minimum Application Rates and Discharge Times for Fixed Foam Application on Diked Areas Involving Hydrocarbon Liquids**

Type of Foam Discharge Outlets	Minimum Application Rate		Minimum Discharge Time (minutes)	
	gpm/ft <sup>2</sup>	mm/min*	Class I Hydrocarbon	Class II Hydrocarbon
Low-level foam discharge outlets	0.10	4.1	30	20
Foam monitors	0.16	6.5	30	20
Foam using compressed air foam technology	Consult manufacturer for listed minimum application rate	Consult manufacturer for listed minimum application rate	30	20

\*L/min-m<sup>2</sup> is equivalent to mm/min.



**Table 5.8.1.2 Minimum Application Rates and Discharge Times for Nondiked Spill Fire Protection Using Portable Foam Nozzles or Monitors**

Foam Type	Minimum Application Rate		Minimum Discharge Time (minutes)	Anticipated Product Spill
	gpm/ft <sup>2</sup>	mm/min*		
Protein and fluoroprotein	0.16	6.5	15	Hydrocarbon
AFFF, FFFP, and alcohol-resistant AFFF or FFFP	0.10	4.1	15	Hydrocarbon
Alcohol-resistant foams	Consult manufacturer for listings on specific products		15	Flammable and combustible liquids requiring alcohol-resistant foam

\*L/min·m<sup>2</sup> is equivalent to mm/min.

**5.7.4.3.1** Methods of fixed protection shall be the same as those described in 5.7.3.3 for hydrocarbon hazards.

**5.7.4.3.2** Application rates shall be in accordance with manufacturer recommendations based on listings or approvals for specific products and corresponding foam-making devices.

**5.7.4.3.3** The minimum discharge time shall be 30 minutes.

**5.8\* Nondiked Spill Areas.**

**5.8.1 Design Criteria for Protection of Spill Fires Involving Hydrocarbons or Flammable and Combustible Liquids Requiring Alcohol-Resistant Foams.**

**5.8.1.1** To determine protection for spill fires, the potential spill area shall be estimated.

**5.8.1.2** Once this area has been determined, Table 5.8.1.2 shall be used to calculate requirements to be used as design criteria for portable nozzles or monitors.

**5.8.1.2.1** Foam types not included in Table 5.8.1.2 shall be permitted where used in accordance with their listing.

**5.9\* Supplementary Protection.**

**5.9.1 Additional Protection.** In addition to the primary means of protection, some types of hazards shall require provisions for supplemental means of protection.

**5.9.2 Supplemental Foam Hose Stream Requirements.**

**5.9.2.1** Approved foam hose stream equipment shall be provided in addition to tank foam installations as supplementary protection for small spill fires.

**5.9.2.2** The minimum number of fixed or portable hose streams required shall be as specified in Table 5.9.2.2 and shall provide protection of the area.

**Table 5.9.2.2 Supplemental Foam Hose Stream Requirements Diameter of Largest Tank**

Diameter of Largest Tank		Minimum Number of Hose Streams Required
ft	m	
Up to 65	Up to 20	1
65 to 120	20 to 36	2
Over 120	Over 36	3

**5.9.2.3** The equipment for producing each foam stream shall have a solution application rate of at least 50 gpm (190 L/min), with the minimum number of hose streams shown in Table 5.9.2.2.

**5.9.2.4** Additional foam-producing materials shall be provided to allow operation of the hose stream equipment simultaneously with tank foam installations as specified in Table 5.9.2.4.

**Table 5.9.2.4 Hose Stream Operating Times, Supplementing Tank Foam Installations**

Diameter of Largest Tank		Minimum Operating Time* (minutes)
ft	m	
Up to 35	Up to 11	10
35 to 95	11 to 29	20
Over 95	Over 29	30

\*Based on simultaneous operation of the required minimum number of hose streams discharging at a rate of 50 gpm (190 L/min).

**Chapter 6 Low-Expansion Foam Sprinkler and Spray Systems**

**6.1 Administration.**

**6.1.1 Scope.** The design, installation, and maintenance of foam-water sprinkler and spray systems shall be in accordance with this chapter. These systems shall be designed with the required density for either foam or water application as the controlling factor, depending on the design purpose of the system. It is not the intent of this standard to specify where foam-water sprinkler and spray protection is required. The determination of where foam-water sprinkler and spray systems are required shall be made in accordance with such applicable building and fire codes or standards such as NFPA 30 or NFPA 409.

**6.1.2\* Purpose.** The purpose of these requirements is to provide a reasonable degree of protection for life and property from fire through installation requirements for foam-water sprinkler and spray systems based on sound engineering principles, test data, and field experience.

**6.1.3 Application.**

**6.1.3.1\*** Because of the dual extinguishing agent discharge characteristic, these systems shall be selectively applicable to combination Class A and Class B hazards.

**6.1.3.2** Foam-water deluge systems are applicable to the protection of two-dimensional flammable liquid hazards. They shall be permitted to be used for any of the purposes or combinations thereof detailed in 6.1.3.2.1 through 6.1.3.2.3.

**6.1.3.2.1 Extinguishment.** The primary purpose of such systems is the extinguishment of fire in the protected hazard. For this purpose, foam solution discharge densities shall be provided by system design, use of selected discharge devices, and provision of supplies of water at required pressures to accomplish the system design. Foam discharge rates shall be able to provide required rates of water discharge from the system until shut off during the design period and following depletion of foam concentrate supplies.

**6.1.3.2.2 Prevention.** Prevention of fire in the protected hazard is a supplemental feature of such systems. Manual operation of a system to discharge foam or water selectively from the discharge devices in case of accumulations of hazardous materials from spills in such occupancies as garages, aircraft hangars, petrochemical plants, paint and varnish plants, or from other causes in the protected area, will afford protection against ignition, pending cleanup measures. In such cases, manual system operation provides foam coverage in the area with water discharge manually available.

**6.1.3.2.3 Control and Exposure Protection.** Control of fire to allow controlled burning of combustible materials where extinguishment is not possible and exposure protection to reduce heat transfer from an exposure fire can be accomplished by water spray or foam, or both, from these special systems. The degree of accomplishment is related strongly to the fixed discharge densities provided by the system design.

**6.1.3.3** Foam of any type is not an effective extinguishing agent on fires involving liquefied or compressed gases (e.g., butane, butadiene, propane), on materials that will react violently with water (e.g., metallic sodium) or that produce hazardous materials by reacting with water, or on fires involving electrical equipment where the electrical nonconductivity of the extinguishing agent is of primary importance.

**6.1.3.4\*** Only alcohol-type foam shall be used on fires in water-soluble solvents and polar solvents. Manufacturers of foam concentrates that are manufactured for the protection of such hazards shall be consulted for applicability.

**6.1.3.5** Consideration shall be given to potential contamination of water supplies, treating systems, and effluent by foam concentrate, foam, or foam solution runoff. The foam concentrate manufacturer and the appropriate AHJ shall be consulted for guidance. (See Annex E.)

## **6.2 General System Requirements.**

### **6.2.1 General System Information.**

**6.2.1.1** Foam-water deluge and preaction systems shall be provided with automatic and auxiliary manual tripping means in accordance with 6.4.10.

**6.2.1.2** Manual operation only shall be permitted for foam-water deluge systems where acceptable to the AHJ.

**6.2.2 Types of Systems.** Foam-water systems shall be of the wet pipe, dry pipe, deluge, or preaction type.

### **6.2.3 Foam Discharge Duration.**

**6.2.3.1** Systems shall deliver foam to the hazards they protect for a specified period at given densities, either prior to water discharge or following water discharge, depending upon system design purpose.

**6.2.3.2** Following completion of discharge of foam solution to the hazards protected, foam-water sprinkler and spray systems shall discharge water until manually shut off.

### **6.2.4\* Reserve Supply of Foam.**

**6.2.4.1** The AHJ shall be consulted as to the means by which a reserve supply of foam concentrate shall be made available.

**6.2.4.2** The reserve supply shall be listed for use with system components. (See 6.5.3.)

### **6.2.5\* Preprimed Systems.**

**6.2.5.1** Wet pipe foam-water systems shall be preprimed with foam-water solution.

**6.2.5.2** Systems shall not be required to be preprimed where recommended by the foam concentrate manufacturer and where approved by the AHJ.

### **6.2.6 Approvals.**

**6.2.6.1** Prior to designing a system for consideration, the AHJ shall be consulted.

**6.2.6.2** All plans and specifications for the installation shall be approved by the AHJ prior to installation, and such authority shall be consulted as to devices and materials used in system construction and as to selection of the foam concentrate to be provided for system use.

**6.2.6.3** All equipment and concentrates shall be approved for the particular application intended.

**6.3 Working Plans.** Working plans shall be in accordance with Chapter 9.

## **6.4 System Components.**

### **6.4.1 Approved Devices and Materials.**

**6.4.1.1** All component parts, including foam concentrates, shall be listed for the use intended.

**6.4.1.2** Where listed components are not manufactured, the components shall be of an approved type.

### **6.4.2 Discharge Devices.**

**6.4.2.1** Discharge devices and foam concentrates shall be listed for use together.

**6.4.2.2** Discharge devices for foam-water deluge and spray shall be permitted to be air-aspirating, such as foam-water sprinkler and foam-water spray nozzles, or they shall be permitted to be non-air-aspirating, such as standard sprinklers.

**6.4.2.3** Discharge devices for foam-water wet pipe, dry pipe, and preaction systems shall be automatic in operation and shall be non-air-aspirating.

**6.4.3\* Foam Concentrate.** Foam concentrates shall be in accordance with the requirements of Section 4.3.

**6.4.4 Foam Concentrate Proportioning Means.** Foam concentrates shall be in accordance with the requirements of Section 4.5.

**6.4.5\* Foam Concentrate Pumps.** Foam concentrate pumps shall be in accordance with the requirements of Section 4.6.

**6.4.6 Foam Concentrate Storage Tanks.** Storage tanks for foam concentrate shall be in accordance with Section 4.3.

**6.4.7 Piping, Valves, Pipe Fittings, and Hangers.**

**6.4.7.1** Piping, valves, pipe fittings, and hangers, including corrosion-protection coatings, shall be in accordance with NFPA 13.

**6.4.7.2\*** Piping, fittings, and valves shall be of a material compatible with the foam concentrate, foam solution, or water used, as applicable.

**6.4.7.2.1\*** Foam concentrate pipe and valves shall be made of one of the following materials:

- (1) Brass (red or naval)
- (2) Bronze
- (3) Stainless steel (304 or 316)
- (4) Other material, in accordance with the foam concentrate manufacturer's certification of compatibility with the foam concentrate and as approved by the AHJ (See 4.7.1.1.)

**6.4.7.2.2\*** Carbon steel pipe shall not be used. (See 4.7.1.2.)

**6.4.7.2.3** Pipe carrying foam concentrate shall not be galvanized. (See 4.7.1.3.)

**6.4.7.2.4** Foam concentrate pipe shall conform to one of the following standards:

- (1) ASTM A312
- (2) ASTM B43
- (3) ASTM B315
- (4) Other standards as allowed by 4.7.1.4

**6.4.7.2.5\*** Foam solution pipe shall be made of one of the following materials:

- (1) Galvanized steel
- (2) Stainless steel
- (3) Internal/external corrosion-resistant pipe in accordance with the foam manufacturer's specification for compatibility and acceptable to the AHJ
- (4) Unprotected carbon steel pipe, when the discharge devices are closed to the atmosphere (See 4.7.2.1.)

**6.4.7.3\*** Rubber-gasketed fittings shall be permitted to be used to connect pipe in fire-exposed areas where the foam-water system is automatically controlled.

**6.4.7.3.1** Fire-exposed areas in which these fittings are located shall be protected by automatic foam-water systems or other approved means.

**6.4.8 Strainers for Foam Concentrate.**

**6.4.8.1** Where listed strainers of the proper size are not available, strainers that have a ratio of open-basket area to inlet pipe size of at least 10:1 shall be used.

**6.4.8.2** Strainers shall be capable of removing all solids of a size that would obstruct system components.

**6.4.8.3** Perforations shall be no larger than the smallest orifice in the system and no less than  $\frac{1}{8}$  in. (3 mm).

**6.4.9 Automatic System Detection.**

**6.4.9.1** Detection required for foam-water deluge systems shall be in accordance with NFPA 15.

**6.4.9.2** Detection required for foam-water preaction systems shall be in accordance with NFPA 13.

**6.4.9.3** Detection and actuation circuitry shall be supervised through a listed panel in accordance with NFPA 72.

**6.4.10\* Test Connections.** System test connections shall be sized to accommodate both the low flow of the proportioner and the maximum anticipated flow through the proportioner.

**6.4.11 Stock of Spare Sprinklers.**

**6.4.11.1\*** A supply of at least six spare sprinklers shall be maintained on the premises so that any sprinklers that have operated or been damaged in any way can be promptly replaced. [13:16.2.7.1]

**6.4.11.2** The sprinklers shall correspond to the types and temperature ratings of the sprinklers in the property. [13:16.2.7.2]

**6.4.11.3** The sprinklers shall be kept in a cabinet located where the temperature to which they are subjected will at no time exceed the maximum ceiling temperatures specified in Table 6.4.11.3 for each of the sprinklers within the cabinet. [13:16.2.7.3]

**6.4.11.4** Where dry sprinklers of different lengths are installed, spare dry sprinklers shall not be required, provided that a means of returning the system to service is furnished. [13:16.2.7.4]

**6.4.11.5** The stock of spare sprinklers shall include all types and ratings installed and shall be as follows:

- (1) For protected facilities having under 300 sprinklers — no fewer than six sprinklers
- (2) For protected facilities having 300 to 1000 sprinklers — no fewer than 12 sprinklers
- (3) For protected facilities having over 1000 sprinklers — no fewer than 24 sprinklers

[13:16.2.7.4]

**6.4.11.6\*** One sprinkler wrench as specified by the sprinkler manufacturer shall be provided in the cabinet for each type of sprinkler installed to be used for the removal and installation of sprinklers in the system. [13:16.2.7.6]

**6.4.11.7** A list of the sprinklers installed in the property shall be posted in the sprinkler cabinet. [13:16.2.7.7]

**6.4.11.7.1\*** The list shall include the following:

- (1) Sprinkler Identification Number (SIN) if equipped; or the manufacturer, model, K-factor, deflector type, thermal sensitivity, and pressure rating
- (2) General description
- (3) Quantity of each type to be contained in the cabinet
- (4) Issue or revision date of the list

[13:16.2.7.7.1]

## 6.5 System Design and Installation.

### 6.5.1 General.

**6.5.1.1** Foam-water sprinkler systems shall meet the minimum design criteria as presented in this chapter.

**6.5.1.2** Except as allowed by 6.5.2.6.2, 6.5.2.2.1(B), and 6.5.6.2, where occupancy standards specify more stringent criteria, they shall take precedence.

**6.5.1.3** The design and installation of foam-water systems shall be entrusted to experienced and responsible persons.

### 6.5.2 Design Criteria.

**6.5.2.1\* Referenced Standards.** System designs shall conform to all the applicable requirements of the following standards unless otherwise specified in this standard:

- (1) NFPA 13
- (2) NFPA 14
- (3) NFPA 15
- (4) NFPA 20
- (5) NFPA 22
- (6) NFPA 24
- (7) NFPA 30
- (8) *NFPA 70*
- (9) *NFPA 72*

### 6.5.2.2\* Design Approach.

**6.5.2.2.1** The design discharge density shall be in accordance with the applicable occupancy standard for water or foam-water systems but in no case less than 0.16 gpm/ft<sup>2</sup> (6.5 mm/m<sup>2</sup>).

**6.5.2.2.1.1** When using SFFF, the user shall refer to Annex H and the manufacturer's recommendations to determine application rates.

### 6.5.2.2.2 Foam-Water Wet Pipe, Dry Pipe, and Preaction Systems.

#### 6.5.2.2.2.1 Total Design Area.

**(A)\*** The total design area shall be 5000 ft<sup>2</sup> (465 m<sup>2</sup>).

**(B)** Where applicable occupancy standards specify design areas different from that specified in 6.5.2.2.2.1(A), the occupancy standards shall take precedence.

**6.5.2.2.3** For the purposes of hydraulic calculations, the water supply shall meet the requirements of 6.2.3.

### 6.5.2.3 Foam Solution Discharge Duration.

**6.5.2.3.1** The foam solution shall be designed to discharge for a period of 10 minutes (based on the density as specified in 6.5.2.2.1) over the entire system area for deluge and spray foam-water systems and over the design area for wet pipe, dry pipe, and preaction foam-water systems.

**6.5.2.3.2** Where actual system discharge exceeds the minimum as specified in 6.5.2.2.1, a proportionate reduction in the duration of the foam discharge time shall be permitted, but in no case shall the duration be less than 7 minutes.

**6.5.2.4 Proportioning System.** The proportioning system selected shall be in accordance with Section 4.5.

**6.5.2.4.1** Foam concentrate pumps shall be designed and installed in accordance with Section 4.6.

**6.5.2.4.2 Power Supply and Controller.** The power supply and controllers for the drivers of foam concentrate pumps shall be installed in accordance with NFPA 20 and *NFPA 70*.

### 6.5.2.5 Foam Concentrate Lines.

**6.5.2.5.1\*** Where foam concentrate lines are run underground or where they run aboveground for more than 50 ft (15 m), these lines shall be maintained full, and a means of checking the tightness of the system shall be provided.

**6.5.2.5.2** The temperature of the foam concentrate lines and components shall be maintained within the storage temperature limits specified for the foam concentrate.

### 6.5.2.6 Containment, Drainage, and Spill Control.

**6.5.2.6.1\*** Facilities shall be provided for the safe removal or retention of the largest anticipated flammable liquid spill plus the free water reaching the floor from the fixed fire protection system, as well as the discharge from hose streams.

**Table 6.4.11.3 Temperature Ratings, Classifications, and Color Codings**

Maximum Ceiling Temperature		Temperature Rating		Temperature Classification	Color Code	Glass Bulb Colors
°F	°C	°F	°C			
100	38	135–170	57–77	Ordinary	Uncolored or black	Orange or red
150	66	175–225	79–107	Intermediate	White	Yellow or green
225	107	250–300	121–149	High	Blue	Blue
300	149	325–375	163–191	Extra high	Red	Purple
375	191	400–475	204–246	Very extra high	Green	Black
475	246	500–575	260–302	Ultra high	Orange	Black
625	329	650	343	Ultra high	Orange	Black

[13:Table 7.2.4.1]

**6.5.2.6.2** Where applicable occupancy standards specify containment or drainage that differs from that specified in 6.5.2.6.1, the occupancy standard shall take precedence.

**6.5.3 Equipment Location.** Equipment items, such as storage tanks and proportioners for foam concentrates; pumps for water and foam concentrates; and control valves for water, foam concentrates, and foam solution, shall be located as near as possible to the hazard or hazards they protect but shall not be exposed to a fire in a manner that is likely to impair system performance.

**6.5.4 Alarms.** Alarms shall be provided in accordance with the requirements of NFPA 13.

#### 6.5.5 Strainers.

**6.5.5.1** Strainers shall be installed so that they are accessible for cleaning or flushing.

**6.5.5.2** Strainers shall be installed so as to be accessible for cleaning (flushing) while maintaining system discharge during an emergency.

#### 6.5.6 Sprinkler Spacing and Location.

**6.5.6.1** Sprinkler spacing shall not exceed 100 ft<sup>2</sup> (9.3 m<sup>2</sup>) per sprinkler or exceed 12 ft (3.7 m) spacing between sprinklers on a branch line or between branch lines. Except in buildings where the primary structural members are 25 ft (7.6 m) apart, the line-to-line distance shall be permitted to be 12 ft 6 in. (3.8 m) where the system has a density of  $\geq 0.25$ .

**6.5.6.2** Where applicable occupancy standards specify a sprinkler spacing different from that specified in 6.5.6.1, the occupancy standards shall take precedence.

**6.5.6.3** For foam-water preaction systems, the requirements of 6.5.8 shall also take precedence.

#### 6.5.7 Temperature Rating.

**6.5.7.1** The temperature rating of sprinklers shall be within the range of 250°F to 300°F (121°C to 149°C) where they are located at the roof or ceiling.

**6.5.7.2** Where sprinklers are located at an intermediate level, the temperature rating shall be within the range of 135°F to 170°F (57°C to 77°C), unless ambient conditions require a higher rating.

#### 6.5.8 Foam-Water Deluge Systems.

##### 6.5.8.1 Tripping.

**6.5.8.1.1\*** In automatic systems, the detection equipment shall be connected to a means for tripping water deluge valves and other system-control equipment.

**6.5.8.1.2** Supplemental manual means for this purpose also shall be provided.

##### 6.5.8.2 Foam Concentrate Injection.

**6.5.8.2.1** In automatic systems, foam concentrate injection shall be activated automatically by, or concurrently with, activation of the main water supply control valve.

**6.5.8.2.2** Manual operating means shall be designed for this same purpose.

**6.5.8.3** Automatic detection equipment, whether pneumatic, hydraulic, or electric, shall be provided with complete supervi-

sion arranged so that failure of equipment, loss of supervising air pressure, or loss of electric energy results in clear notification of the abnormal condition.

**6.5.8.4** Where used in a corrosive atmosphere, the detection devices shall be of materials not subject to corrosion or of materials protected to resist corrosion.

**6.5.8.5\*** Automatic detection equipment of the electric type and any auxiliary equipment of the electric type, if in hazardous areas, shall be designed specifically for use in such areas.

**6.5.8.6** In automatic systems, manually operated tripping devices shall actuate the automatic control valve by mechanical, pneumatic, electric, or other approved means.

**6.5.8.6.1** The manual device shall be strong enough to prevent breakage.

**6.5.8.6.2** Manual controls shall not necessitate a pull of more than 40 lb (force) [178 N] or a movement of more than 14 in. (356 mm) to secure operation.

#### 6.5.9 Fire Department Connection.

**6.5.9.1\*** When a fire department connection is required, it shall be installed on the supply side of the proportioner.

**6.5.9.2** Where a fire department connection is provided, the following items shall be evaluated before installation or use:

- (1) Overpressurizing of system components
- (2) Imbalance of proportioning equipment
- (3) Dilution of proportioned foam solution
- (4) Disturbance of system accessory devices including, but not limited to, the following:
  - (a) Pressure switches
  - (b) Hydraulic control valves
  - (c) Main control valve trim
- (5) Pressures and flows exceeding the foam system design capability

**6.5.9.3** A sign that states the following shall be placed at the fire department connection:

FIRE DEPARTMENT CONNECTION  
THIS CONNECTION FEEDS A FOAM-WATER SPRINKLER  
SYSTEM.  
DO NOT PUMP AT PRESSURES  
EXCEEDING [*insert design pressure*] UNTIL FOAM  
LIQUID SUPPLY IS EXHAUSTED.  
IF INCIDENT IS CONTROLLED BY FOAM BLANKET, DO  
NOT DESTROY FOAM BLANKET BY EXCESSIVE APPLI-  
CATION  
OF WATER.

#### 6.5.10 Hydraulic Calculations.

##### 6.5.10.1 Foam-Water Deluge Systems.

**6.5.10.1.1** System piping shall be hydraulically designed to obtain uniform foam and water distribution and to allow for loss of head in water supply piping.

**6.5.10.1.1.1** The adjustment in pipe sizes shall be based on a maximum variation of 20 percent above the specified discharge rate per sprinkler or nozzle.

**6.5.10.1.2** Pipe sizes shall be adjusted according to detailed friction-loss calculations.

**6.5.10.1.2.1** These calculations shall show the relationship between the water supply and the water demand.

**6.5.10.1.3** Hydraulic calculations for piping carrying water or foam solution shall be in accordance with NFPA 13.

**6.5.10.1.3.1** Piping carrying foam solution shall be sized as if carrying plain water.

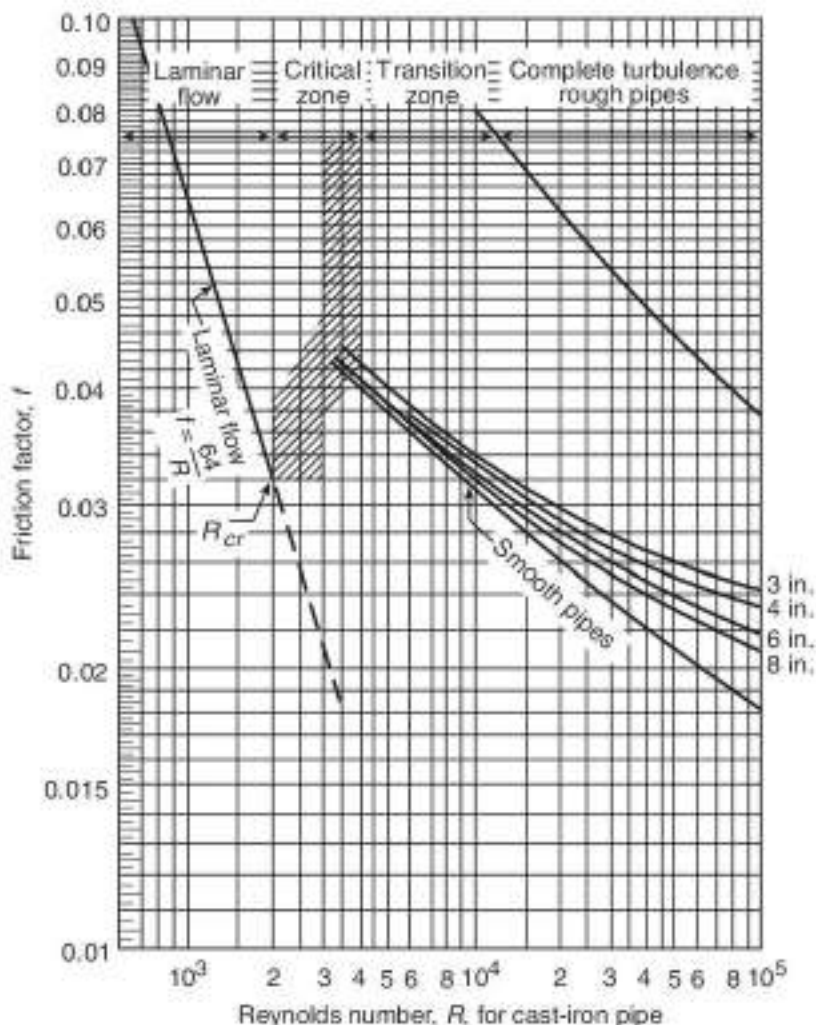
**6.5.10.1.4\*** The friction losses in piping carrying foam concentrate shall be calculated using the Darcy-Weisbach formula.

**6.5.10.1.4.1** Friction factors for use with the Darcy-Weisbach formula shall be selected from the graphs shown in Figure 6.5.10.1.4.1(a) through Figure 6.5.10.1.4.1(d).

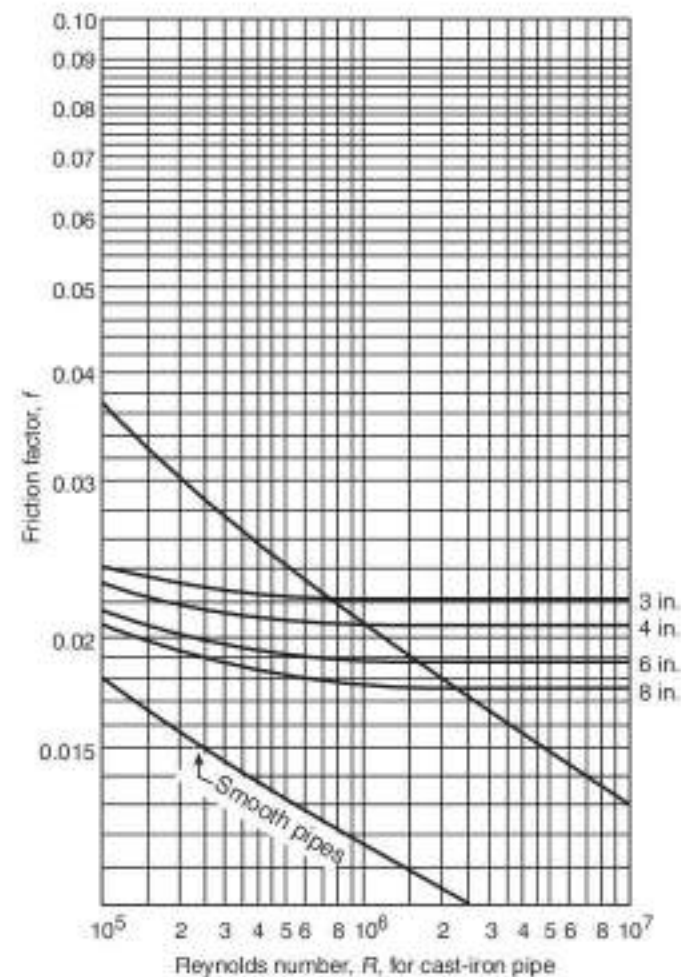
**6.5.10.1.4.2** In calculating the Reynolds number for selecting friction factors from the graphs, the actual density (or specific gravity) of the foam concentrate to be employed in the system shall be used.

**6.5.10.1.4.3** The viscosity used shall be the actual viscosity of the foam concentrate at the lowest anticipated storage temperature.

**6.5.10.1.4.4\*** For purposes of computing friction loss in piping using alcohol-resistant foam concentrate, the designer shall consult the foam concentrate manufacturer for friction characteristics.



**FIGURE 6.5.10.1.4.1(a)** Moody Diagram for Cast-Iron Pipe,  $R \leq 10^5$ .



**FIGURE 6.5.10.1.4.1(b)** Moody Diagram for Cast-Iron Pipe,  $R \geq 10^5$ .

**6.5.10.1.5** For purposes of computing friction loss in piping, the  $C$  values shall be used for the Hazen-Williams formula in accordance with Table 6.5.10.1.5.

#### 6.5.10.2 Foam-Water Wet Pipe, Dry Pipe, and Preaction Systems.

**6.5.10.2.1** System piping shall be hydraulically designed to obtain uniform foam and water distribution and to allow for loss of head in system piping.

**6.5.10.2.2\*** Two sets of hydraulic calculations shall be provided, as follows:

- (1) Actual calculated demand flow and pressure based on the most hydraulically demanding condition, balanced to the available water supply
- (2) Actual calculated demand flow and pressure based on the least hydraulically demanding design area, balanced to the available water supply

**6.5.10.2.3\*** Hydraulic balance to, and comparison with, the available water supply shall verify that the actual system discharge will not exceed the capability of the foam concentrate supply to provide foam solution discharge as specified in 6.5.2.3.1 and 6.5.2.3.2.

**6.5.10.2.4** Pipe sizes shall be adjusted according to detailed friction-loss calculations.

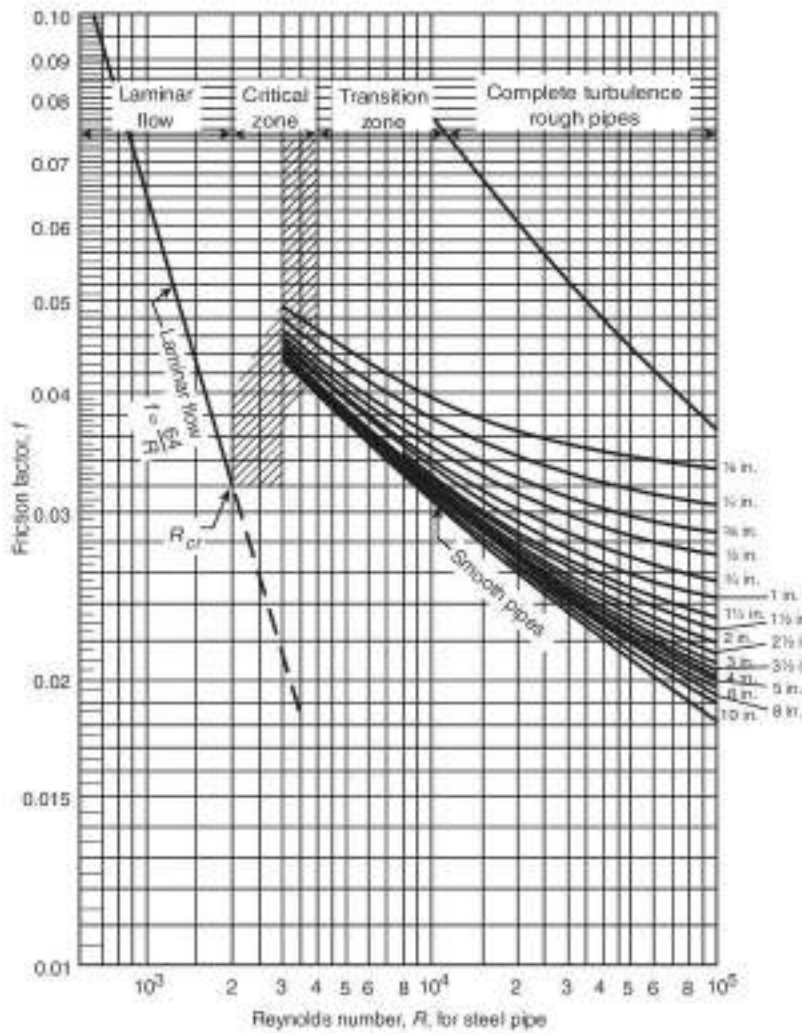


FIGURE 6.5.10.1.4.1(c) Moody Diagram for Steel Pipe,  $R \leq 10^5$ .

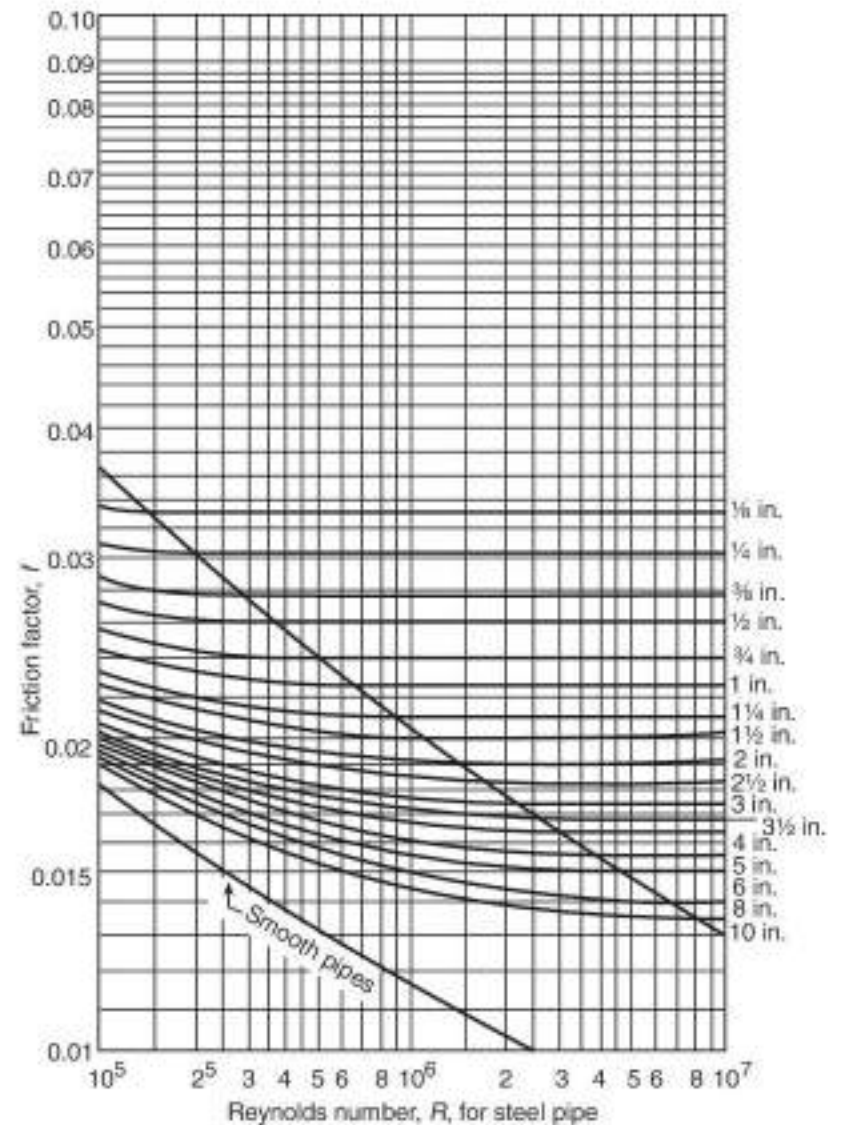


FIGURE 6.5.10.1.4.1(d) Moody Diagram for Steel Pipe,  $R \geq 10^5$ .

6.5.10.2.4.1 Friction-loss calculations shall show the relationship between the water supply and system demand.

6.5.10.2.5 Hydraulic calculations for determining the foam solution and water flow characteristics of systems covered by this standard shall be in accordance with NFPA 13.

6.5.10.2.5.1 Friction-loss characteristics for foam solution piping shall be considered the same as if the piping were carrying water.

6.5.10.2.6 For purposes of computing friction loss in piping, the  $C$  values in Table 6.5.10.1.5 shall be used in the Hazen-Williams formula.

**6.5.10.3 Friction Loss.**

6.5.10.3.1 The friction loss in piping carrying foam concentrate shall be calculated in accordance with the requirements of 6.5.10.1.4.

6.5.10.3.2 For purposes of computing friction loss in piping using alcohol-resistant foam concentrate, the designer shall consult the foam concentrate manufacturer for friction characteristics.

**6.6 Acceptance Tests.** Acceptance tests shall be in accordance with Section 12.9.

Table 6.5.10.1.5 Hazen-Williams  $C$  Values

Pipe or Tube	$C$ Value*
Unlined cast or ductile iron	100
Black steel (dry systems including preaction)	100
Black steel (wet systems including deluge)	120
Galvanized steel (dry systems including preaction)	100
Galvanized steel (wet systems including deluge)	120
Plastic (listed) all	150
Cement-lined cast or ductile iron	140
Copper tube, brass or stainless steel	150
Asbestos cement	140
Concrete	140

\*The authority having jurisdiction is permitted to allow other  $C$  values. [13:Table 27.2.4.8.1]

**6.7 Inspection, Testing, and Maintenance.** Inspection, testing, and maintenance shall be in accordance with Chapter 13.

## Chapter 7 Medium- and High-Expansion Systems

**7.1\* General Information and Requirements.** This chapter shall apply to requirements for a design of medium- and high-expansion foam systems.

### 7.2 Use and Limitations.

**7.2.1** Medium- and high-expansion foams shall be specifically evaluated to verify the applicability of medium- or high-expansion foam as a fire control agent for the type of hazard.

**7.3\* Hazards Protected.** Hazards that medium- and high-expansion foam systems shall be permitted to protect include the following:

- (1) Ordinary combustibles
- (2) Flammable and combustible liquids
- (3) Combinations of (1) and (2)
- (4) Liquefied natural gas (high-expansion foam only)

**7.3.1** Susceptibility of the protected hazard to water damage shall be evaluated.

**7.3.2\*** Medium- and high-expansion foam systems shall not be used on fires in the following hazards except where component evaluation, including tests, indicates acceptability:

- (1) Chemicals, such as cellulose nitrate, that release oxygen or other oxidizing agents to sustain combustion
- (2) Energized unenclosed electrical equipment
- (3) Water-reactive metals such as sodium, potassium, and NaK (sodium-potassium alloys)
- (4) Hazardous water-reactive materials, such as triethyl-aluminum and phosphorus pentoxide
- (5) Liquefied flammable gas

**7.4 Types of Systems.** The types of systems within the scope of this standard shall be provided as follows:

- (1) Total flooding systems
- (2) Local application systems
- (3) Portable foam-generating devices

### 7.5 Systems Protecting One or More Hazards.

**7.5.1** Systems shall be permitted to be used to protect one or more hazards or groups of hazards by means of the same supply of foam concentrate and water.

**7.5.2** Where, in the opinion of the AHJ, two or more hazards can be simultaneously involved in fire by reason of their proximity, each hazard shall be protected with an individual system, or the system shall be arranged to discharge on all potentially involved hazards simultaneously.

### 7.6\* Occupant Safety and Rescue Operations.

#### 7.6.1\* Occupant Evacuation.

**7.6.1.1** Facility occupants shall be briefed on system operation (activation and emergency shutdown) and evacuation procedures.

**7.6.1.2** Upon system activation, occupants shall evacuate the facility and assemble in a predetermined location to conduct a count of personnel.

**7.6.1.3** Foam discharge points relative to building exits shall not inhibit evacuation where possible.

#### 7.6.2\* Rescue Operations.

**7.6.2.1** Upon notification of entrapped occupant(s), only trained rescue personnel wearing full personal protective equipment with self-contained breathing apparatus shall enter the foam-filled facility.

**7.6.2.2\*** To facilitate rescue operations, facility doors shall be fully opened and a blended attack of coarse water and industrial silicone-based de-foaming agent shall be utilized.

**7.6.2.2.1** Facility foam generators shall remain operational (water only) to aid in foam dispersion.

**7.6.2.3\*** Rescue personnel shall use a straight-line search pattern and search wands to effectively cover large floor spaces.

**7.6.2.3.1\*** To ensure effective communications, rescue personnel shall remain within line-of-sight of each other.

#### 7.6.3\* Electrical Clearances.

**7.6.3.1** All system components shall be located to maintain minimum clearances from live parts as shown in Table 7.6.3.1.

**7.6.3.2** The clearances given are for altitudes of 3281 ft (1000 m) or less.

**7.6.3.2.1\*** At altitudes in excess of 3281 ft (1000 m), the clearance shall be increased at the rate of 1 percent for each 328 ft (100 m) increase in altitude above 3281 ft (1000 m).

**7.6.3.2.2** To coordinate the required clearance with the electrical design, the design BIL of the equipment being protected

**Table 7.6.3.1 Clearance from Medium- and High-Expansion Foam Equipment to Live Uninsulated Electrical Components**

Nominal Line Voltage (kV)	Nominal Voltage to Ground (kV)	Design BIL* (kV)	Minimum Clearance	
			in.	mm
To 15	To 9	110	7	178
23	13	150	10	254
34.5	20	200	13	330
46	27	250	17	432
69	40	350	25	635
115	66	550	37	940
138	80	650	44	1118
161	93	750	52	1321
196–230	114–132	900	63	1600
		1050	76	1930
		1175	87	2210
		1300	98	2489
287–380	166–220	1425	109	2769
		1550	120	3048
		1675	131	3327
500	290	1800	142	3607
		1925	153	3886
		2100	168	4267
		2300	184	4674

\*Basic insulation level (BIL) values are expressed as kilovolts (kV), the number being the crest value of the full wave impulse test that the electrical equipment is designed to withstand.



shall be used as a basis, although this is not material at nominal line voltages of 161 kV or less.

**7.6.3.2.3** At voltages higher than 161 kV, uniformity in the relationship between design BIL kV and the various electrical system voltages has not been established in practice and is dependent on several variables; thus, the required clearances to ground shall be based on the design BIL used rather than on the nominal line or ground voltage.

**7.6.3.2.4** The clearance between uninsulated energized parts of the electrical system equipment and any portion of the medium- or high-expansion foam system shall not be less than the minimum clearance provided elsewhere for electrical system insulations on any individual component.

## **7.7 Operation and Control of Systems.**

### **7.7.1\* Detection of Fires.**

**7.7.1.1** Automatic detection shall be used for fixed systems.

**7.7.1.1.1\*** Removal of automatic detection shall be permitted when approved by the AHJ.

**7.7.1.2\*** Automatic detection shall be by listed or approved methods or devices capable of detection and indicating heat, smoke, or flame. Automatic detection devices shall be installed in accordance with *NFPA 72*.

**7.7.1.3** Detection by the use of combustible vapor detectors or an abnormal condition in the hazard, such as process trouble, shall be arranged using approved industrial practices as specified by an engineering study.

**7.7.1.4\*** A reliable source of energy shall be used in detection systems.

**7.7.1.4.1** The power supply for electrical detection systems shall be independent of the supply for the protected area.

**7.7.1.4.2** Arrangement of the power supply shall be in accordance with requirements of *NFPA 72* for continuity of power supplies.

**7.7.2 Supervision.** Supervision of automatic detection and actuation equipment shall be provided and arranged so that there will be an immediate indication of failure, preferably at a constantly attended location.

### **7.7.3 Alarms.**

**7.7.3.1** Audible alarms shall be installed to indicate the operation of the system, to alert personnel, and to indicate failure of any supervised device or equipment.

**7.7.3.2** Such devices shall be of such a type and shall be provided in such numbers and at such locations as are necessary to accomplish their purpose satisfactorily.

**7.7.3.3** An alarm shall be provided to show that the system has operated.

**7.7.3.4** Alarms shall be provided to give ample warning of discharge where hazard(s) to personnel exist.

**7.7.3.5** Alarms indicating failure of supervised devices or equipment shall give prompt and positive indication of any failure and shall be distinctive from alarms indicating operation or hazardous conditions.

### **7.7.4\* Operating Devices.**

**7.7.4.1** Operating devices shall include foam generators, valves, proportioners, eductors, discharge controls, and shut-down equipment.

**7.7.4.1.1** Operation shall be controlled by listed or approved mechanical, electrical, hydraulic, or pneumatic means.

**7.7.4.1.2** A reliable source of energy shall be used.

**7.7.4.1.3** The electrical power supply for an electrically operated medium- or high-expansion foam system shall be as reliable as a fire pump circuit in accordance with *NFPA 20*.

**7.7.4.2** All operating devices shall be approved for the service they will encounter and shall not be rendered inoperative or susceptible to accidental operation.

**7.7.4.2.1** Provision shall be made to protect piping that is normally filled with liquid from freezing.

**7.7.4.3** All devices shall be located, installed, or suitably protected so that they are not subject to mechanical, chemical, climatic, or other conditions that will render them inoperative.

**7.7.4.4** Manual controls for actuation and shutdown shall be conveniently located and accessible at all times, including the time of fire and system operation.

**7.7.4.4.1** Remote control stations for manual actuation shall be considered where the area is large, where egress is difficult, or where required by the AHJ.

**7.7.4.4.2** Manual controls for actuation shall operate the system to the same extent as the automatic control.

**7.7.4.5** All automatically operated equipment controlling the generation and distribution of foam shall be provided with approved independent means for emergency manual operation.

**7.7.4.5.1** If the means for manual actuation of the system required in 7.7.1 provide approved positive operation independent of the automatic actuation, it shall be permitted to be used as the emergency means.

**7.7.4.5.2** The emergency means, preferably mechanical, shall be accessible and located close to the equipment controlled.

**7.7.4.5.3** If possible, the system shall be designed so that complete emergency actuation shall be permitted to be accomplished from one location.

**7.7.4.6** All required door and window closers, vent openers, and electrical equipment shutdown devices shall be considered integral parts of the system and shall function simultaneously with the system operation.

**7.7.4.7** All manual operating devices shall be identified with signs as to the hazards they protect.

## **7.8 Foam Concentrate.**

**7.8.1 Quality.** See Annex G.

**7.8.1.1** The foam concentrate used in the system shall be listed for use with the equipment.

**7.8.1.2** The quality of the concentrate for performance under the installation requirements of this standard shall be determined by tests.

## 7.9 Air Supply.

**7.9.1** Air from outside the hazard area shall be used for foam generation unless data is provided to show that air from inside the hazard can be successfully employed.

**7.9.2** The data shall be specific for the products of combustion to be encountered and shall provide factors for increasing foam discharge rates over those given in 7.12.8 if fire tests indicate that need.

**7.9.3** Vents from the fire area shall be located to prevent recirculation of combustion products or other materials deleterious to the formation of foam into foam generator air inlets.

## 7.10 Foam-Generating Apparatus Location.

**7.10.1 Accessibility for Inspection and Maintenance.** Foam-generating apparatus shall be located and arranged so that inspection, testing, recharging, and other maintenance is facilitated and interruption of protection is held to a minimum.

### 7.10.2\* Protection Against Exposure.

**7.10.2.1** Foam-generating equipment shall be located as close as possible to the hazard(s) it protects, but not where it will be unduly exposed to a fire or explosion.

**7.10.2.2** Foam generators installed inside the hazard area shall be listed to resist or be protected against fire exposure for the duration of the fire.

**7.10.2.3** Such protection shall be permitted to be in the form of insulation, water spray or sprinklers, or other method as determined by an engineering study.

**7.10.2.4** In certain applications, additional generators shall be permitted to be substituted for fire exposure protection based on results of fire tests.

## 7.11 Distribution Systems.

**7.11.1 Piping and Fittings.** Piping and fittings shall conform to the requirements of Chapter 4.

### 7.11.2 Arrangement and Installation of Piping and Fittings.

**7.11.2.1** A listed strainer for use with the proportioner and foam generator shall be provided in the water line upstream of the water valve.

**7.11.2.2** Supplemental strainers shall be permitted to be used as recommended by the foam equipment manufacturer.

### 7.11.3 Ducts.

**7.11.3.1** Foam distribution and air inlet ducts shall be designed, located, installed, and suitably protected so that they are not subject to undue mechanical, chemical, or other damage.

**7.11.3.2** Duct closures such as selector valves, gates, or doors shall be of the quick-opening type, so as to allow free passage of the foam.

**7.11.3.2.1** When duct closures are located where they are subjected to fire or heat exposure, either inside or outside the area to be protected, special care shall be taken to ensure positive operation.

**7.11.3.3** Ducts shall be designed and installed so that undue turbulence is avoided, and the actual foam discharge rate shall be determined by test or other method acceptable to the AHJ.

## 7.12 Total Flooding Systems General Information.

**7.12.1 Description.** A total flooding system shall consist of fixed foam-generating apparatus complete with a piped supply of foam concentrate and water, arranged to discharge into an enclosed space or enclosure around the hazard.

**7.12.2\* Applications.** Total flooding systems shall be permitted to be used where a permanent enclosure is provided around the hazard to enable the required amount of fire-extinguishing medium to accumulate at the proper depth and to be maintained for a period of time required to ensure fire control or extinguishment in a specific combustible material.

### 7.12.3 General Requirements.

**7.12.3.1** Total flooding systems shall be designed, installed, tested, and maintained in accordance with the applicable requirements of this standard.

**7.12.3.2** Only listed or approved equipment and devices shall be used in these systems.

### 7.12.4 Total Flooding Enclosure Specifications.

#### 7.12.4.1\* Leakage.

**7.12.4.1.1 Openings.** Openings below design filling depth, such as doorways and windows, shall be arranged to close automatically before, or simultaneously with, the start of the foam discharge, with due consideration for evacuation of personnel.

**7.12.4.1.1.1** Openings shall be designed to maintain closure during a fire and shall be capable of withstanding pressures of foam and sprinkler water discharge.

**7.12.4.1.1.2** Where openings cannot be protected by automatic closing devices, the total flooding system shall be designed to compensate for the probable loss of foam.

(A) The system design shall be tested to ensure proper performance.

(B) If the foam system is permitted to start prior to complete closure of the space to be filled, additional foam output shall be allowed to compensate for the losses.

(C) This shall be verified by test based on the individual site conditions.

#### 7.12.4.1.2 Ventilation.

**7.12.4.1.2.1** Where outside air is used for foam generation, high-level venting shall be provided for air that is displaced by the foam.

**7.12.4.1.2.2** Venting velocity shall not exceed 1000 ft/min (305 m/min) in free air.

**7.12.4.1.2.3** The required venting shall consist of openings, either normally open or normally closed and arranged to open automatically when the system operates.

**7.12.4.1.2.4** Where design criteria demand exhaust fans, they shall be approved for high-temperature operation and installed with consideration for protection of switches, wiring, and other electrical devices to ensure equal reliability of exhaust fan performance. Operation of the fans shall not compromise foam generator operations.

**7.12.4.1.2.5** Where forced-air ventilating systems interfere with the proper buildup of foam, they shall be automatically shut down or closed.

### 7.12.5 Foam Requirements.

**7.12.5.1 General.** Total flooding medium- or high-expansion foam shall be discharged at a rate required to fill the enclosure to a depth above the hazard before an unacceptable degree of damage occurs.

#### 7.12.5.2 Foam Depth.

##### 7.12.5.2.1 High-Expansion Foam.

**7.12.5.2.1.1** The minimum total depth of foam shall be not less than 1.1 times the height of the highest hazard but in no case less than 24 in. (600 mm) over this hazard.

**7.12.5.2.1.2** For flammable or combustible liquids, the required depth over the hazard shall be permitted to be considerably greater than the requirement of 7.12.5.2.1.1 and shall be no less than the depth determined by tests. Tests shall duplicate the anticipated fire event in the protected area.

##### 7.12.5.2.2 Medium-Expansion Foam.

**7.12.5.2.2.1** Required depth over the hazard shall vary with expansion.

**7.12.5.2.2.2** Depth shall be determined by tests. (See 7.12.6.3 and Annex G.)

#### 7.12.6 Submergence Volume for High-Expansion Foams.

**7.12.6.1** Submergence volume for sprinkler protected areas shall be defined as the depth as specified in 7.12.5.2.2.2 multiplied by the floor area of the space to be protected in accordance with 7.12.3.

**7.12.6.2** Submergence volume for unsprinklered rooms of combustible construction or finish shall be based on the entire volume, including concealed spaces.

**7.12.6.3** The volume occupied by vessels, machinery, or other permanently located equipment shall be permitted to be deducted when determining the submergence volume.

**7.12.6.4** The volume occupied by stored material shall not be deducted when determining the submergence volume.

#### 7.12.7 Submergence Time for High-Expansion Foams.

**7.12.7.1\*** Recommended times to achieve submergence volume for various types of hazards and building construction shall be as shown in Table 7.12.7.1 and in accordance with NFPA 220, Table 4.1.1.

**7.12.7.2** Shorter submergence times shall be permitted to be required depending on the factors included in 7.12.8.

**7.12.7.3** The submergence time shall be based on a maximum of 30 seconds delay between fire detection and start of foam discharge.

**7.12.7.4** Any delays in excess of 30 seconds shall be deducted from the submergence times in Table 7.12.7.1.

**7.12.7.5** Where use of high-expansion foam on polar solvents is contemplated, the foam equipment supplier shall substantiate suitability for the intended use.

#### 7.12.8\* Rate of Discharge.

**7.12.8.1 Medium-Expansion Foam.** The rate of discharge for medium-expansion foam shall be determined by tests.

##### 7.12.8.2 High-Expansion Foam.

**7.12.8.2.1\*** The rate of foam discharge necessary for extinguishment or control to permit overhaul shall be dependent on the strength of sprinkler protection, the nature and configuration of the hazard, the vulnerability of the structure and contents to fire, and the loss potential to life, property, and production.

**7.12.8.2.2** The foam discharge rate shall meet the foam depth requirements and submergence times of Table 7.12.7.1, with

**Table 7.12.7.1 Maximum Submergence Time for High-Expansion Foam Measured from Start of Foam Discharge in Minutes**

Hazard	Construction Type			
	Type II (000), Type III (200), Type V (000)		Type I (all), Type II (222, 111), Type IV (2HH), Type V (111)	
	Sprinklered	Not Sprinklered	Sprinklered	Not Sprinklered
Flammable liquids [flash points below 100°F (38°C)] having a vapor pressure not exceeding 40 psia (276 kPa)	3	2	5	3
Combustible liquids [flash points of 100°F (38°C) and above]*	4	3	5	3
Low-density combustibles (i.e., foam rubber, foam plastics, rolled tissue, or crepe paper)	4	3†	6	4†
High-density combustibles (i.e., rolled paper kraft or coated banded)	7	5†	8	6†
High-density combustibles (i.e., rolled paper kraft or coated unbanded)	5	4†	6	5†
Rubber tires	7	5†	8	6†
Combustibles in cartons, bags, or fiber drums	7	5†	8	6†

\*Polar solvents are not included in this table. Flammable liquids having boiling points lower than 100°F (38°C) might require higher application rates. See NFPA 30.

†These submergence times might not be directly applicable to storage piled above 15 ft (4.6 m) or where fire spread through combustible contents is very rapid.

compensation for normal foam shrinkage, foam leakage, and breakdown effects of sprinkler discharge.

#### 7.12.8.2.3 Calculation.

**7.12.8.2.3.1\*** The minimum rate of discharge or total generator capacity shall be calculated from the following formula:

$$R = \left( \frac{V}{T} + R_s \right) \times C_N \times C_L \quad [7.12.8.2.3.1]$$

where:

- $R$  = rate of discharge in ft<sup>3</sup>/min (m<sup>3</sup>/min)
- $V$  = submergence volume in ft<sup>3</sup>/min (m<sup>3</sup>/min)
- $T$  = submergence time in minutes
- $R_s$  = rate of foam breakdown by sprinklers in ft<sup>3</sup>/min (m<sup>3</sup>/min)
- $C_N$  = compensation for normal foam shrinkage
- $C_L$  = compensation for leakage

**7.12.8.2.3.2\*** The factor ( $R_s$ ) for compensation for breakdown by sprinkler discharge shall be determined either by test or, in the absence of specific test data, by the following formula:

$$R_s = S \times Q \quad [7.12.8.2.3.2]$$

where:

- $S$  = foam breakdown in ft<sup>3</sup>/min · gpm (m<sup>3</sup>/min · L/min) of sprinkler discharge.  $S$  shall be 10 ft<sup>3</sup>/min · gpm (0.0748 m<sup>3</sup>/min · L/min).
- $Q$  = estimated total discharge from maximum number of sprinklers expected to operate in gpm (L/min).

**7.12.8.2.3.3** The factor ( $C_N$ ) for compensation for normal foam shrinkage shall be 1.15, which is an empirical factor based on average reduction in foam quantity from solution drainage, fire, wetting of surfaces, absorbency of stock, and so forth.

**7.12.8.2.3.4\*** The factor ( $C_L$ ) for compensation for loss of foam due to leakage around doors and windows and through unclosable openings shall be determined by the design engineer after evaluation of the structure. This factor shall not be permitted to be less than 1.0 even for a structure completely tight below the design filling depth. This factor shall be permitted to be as high as 1.2 for a building with all openings normally closed, depending on foam expansion ratio, sprinkler operation, and foam depth.

#### 7.12.9 Quantity.

**7.12.9.1** High-expansion foam concentrate and water shall be provided to permit continuous operation of the entire system for 25 minutes or to generate four times the submergence volume, whichever is less, but in no case less than enough for 15 minutes of full operation.

**7.12.9.2** The quantity for medium-expansion foam shall be determined by tests developed by an independent testing laboratory.

**7.12.9.3** Reserve supplies shall be provided in accordance with 7.12.9.

#### 7.12.10\* Maintenance of Submergence Volume for High-Expansion Foam.

**7.12.10.1** To ensure control or extinguishment, the submergence volume shall be maintained for at least 60 minutes for unsprinklered locations and 30 minutes for sprinklered locations.

**7.12.10.2** Where the hazard consists of flammable or combustible liquids in noncombustible containers, the time in 7.12.10.1 shall be permitted to be reduced.

#### 7.12.10.3 Method.

**7.12.10.3.1** The submergence volume shall be permitted to be maintained by continuous or intermittent operation of any or all of the generators provided.

**7.12.10.3.2\*** Arrangements and procedures shall be provided to maintain the submergence volume without waste of foam concentrate.

**7.12.10.4\* Overhaul.** Overhaul procedures shall be preplanned to prevent loss of control by submergence of the hazard.

**7.12.10.5 Distribution.** The medium- and high-expansion foam generators shall be located such that a relatively even buildup of foam will take place throughout the protected area during the discharge period.

#### 7.13 Local Application Systems.

##### 7.13.1 General Information.

**7.13.1.1 Description.** A local application system shall consist of fixed foam-generating apparatus complete with a piped supply of foam concentrate and water that is arranged to discharge foam directly onto a fire or spill hazard.

##### 7.13.1.2\* Uses.

**7.13.1.2.1** Local application systems shall be permitted to be used for the extinguishment or control of fires in flammable or combustible liquids, liquefied natural gas (LNG), and ordinary Class A combustibles where the hazard is not totally enclosed.

**7.13.1.2.2** For multiple-level or three-dimensional fire hazards where total building flooding is impractical, the individual hazard shall be provided with containment facilities.

##### 7.13.2 General Requirements.

**7.13.2.1** Local application systems shall be designed, installed, tested, and maintained in accordance with the applicable requirements in this standard.

**7.13.2.2** Only listed or approved equipment, devices, and agents shall be used in these systems.

##### 7.13.3 Hazard Specifications.

**7.13.3.1 Extent of Hazard.** The hazard shall include all areas to or from which fire shall spread.

##### 7.13.3.2\* Location of Hazard.

**7.13.3.2.1** Local application medium- and high-expansion foam systems shall be permitted to be used to protect hazards located indoors, under partial shelter, or completely outdoors.

**7.13.3.2.2** Provisions shall be made to compensate for winds and other effects of weather.

**7.13.3.3 Foam Requirements for Flammable and Combustible Liquids and Solids.**

**7.13.3.3.1 General.** Foam shall be discharged at a rate to cover the hazard to a depth of at least 24 in. (600 mm) within 2 minutes.

**7.13.3.3.2 Quantity.**

**7.13.3.3.2.1** Foam concentrate and water shall be provided to permit continuous operation of the entire system for at least 12 minutes.

**7.13.3.3.2.2** Reserve supplies shall be provided in accordance with 7.12.9.

**7.13.3.3.3 Arrangement.**

**7.13.3.3.3.1** Discharge outlets shall be arranged to ensure that foam is delivered over all areas that constitute the hazard.

**7.13.3.3.3.2** Where parts of the hazard are elevated or raised up from the ground or floor line, the arrangement of the system shall be such that foam will be delivered to, and retained on, such parts in the required depth to ensure prompt and final extinguishment.

**7.14\* Foam Applications for Liquefied Natural Gas (LNG).****7.14.1\* System Design Considerations.**

**7.14.1.1** The determination of the high-expansion foam system design shall depend on an analysis specific to the individual site.

**7.14.1.2** The analysis shall include effects of heat exposure on adjacent plant equipment.

**7.14.1.3** Automatic alarms and actuation shall be required for fixed systems.

**7.14.1.3.1** Where an engineering study shows that automatic protection is not required, the system shall be permitted to be activated manually.

**7.14.2\* Foam Discharge Rate per Unit Area.**

**7.14.2.1** The discharge rate per unit area shall be established by tests and shall be able to achieve a positive and progressive reduction in radiation within the time limitations established in the analysis.

**7.14.2.2** The discharge rate per unit area determined by the test in Section G.4 shall be increased by the necessary factor to account for the initial vaporization rate and the configuration of the hazard.

**7.14.2.3** After steady-state control conditions have been reached, the discharge rate per unit area established in the test for maintenance of fire control shall be used to maintain control.

**7.14.3 Quantity.**

**7.14.3.1** The initial quantity of foam concentrate shall permit a continuous application at the initial design rate for fire control to reach steady-state conditions.

**7.14.3.2** Additional foam concentrate supplies shall be on hand to provide control maintenance for the calculated fire duration.

**7.14.3.3\* Foam System Arrangement.** The foam system shall have foam outlets arranged to supply foam to cover the design fire area within the specified time.

**7.15 Portable Foam-Generating Devices.****7.15.1 General Information.****7.15.1.1 Description.**

**7.15.1.1.1** Portable foam-generating devices consist of a foam generator, manually operable and transportable, connected by means of hose, or piping and hose, to a supply of water and foam concentrate.

**7.15.1.1.2** The proportioning equipment shall be integral to or separate from the foam generator.

**7.15.1.1.3** A separate foam concentrate supply shall be permitted to be provided for each unit, or solution shall be permitted to be piped from central proportioning equipment.

**7.15.1.2 General Requirements.**

**7.15.1.2.1** Portable foam-generating devices and associated equipment shall be used and maintained in accordance with the applicable requirements in this standard.

**7.15.1.2.2** Only listed or approved equipment and devices shall be used.

**7.15.2 Hazard Specifications.** Portable foam-generating devices shall be permitted to be used to combat fires in all hazards covered in this chapter.

**7.15.3 Location and Spacing.**

**7.15.3.1** Portable foam-generating devices that are preconnected to a water or solution supply shall be placed where they are accessible and shall have enough hose to reach the most distant hazard they are expected to protect.

**7.15.3.2** Foam concentrate shall be accessible for immediate use.

**7.15.3.3** Portable foam generators shall be located such that they are not exposed to the hazard.

**7.15.3.4** When portable foam generators are not preconnected to a water or solution supply, their associated equipment shall be located and arranged for immediate transport to all designated hazards.

**7.15.4 Foam Requirements.****7.15.4.1 Rate and Duration of Discharge.**

**7.15.4.1.1** The rate and duration of discharge, and consequently the quantity of foam concentrate and water, shall be determined by the type and potential size of hazard.

**7.15.4.1.2** To the extent that the specific hazards are identified, the applicable requirements of this chapter shall apply.

**7.15.4.1.3 Simultaneous Use of Portable Foam-Generating Devices.** Where simultaneous use of two or more devices is possible, supplies of foam concentrate and water shall be accessible to supply the maximum number of devices that are physically possible to be used at any one time.

### 7.15.5 Equipment Specifications.

#### 7.15.5.1 Hose.

7.15.5.1.1 Hose used to connect the generator to the water or solution supplies shall be listed lined hose meeting requirements of NFPA 1961.

7.15.5.1.2 The hose size and length shall be selected with consideration to the hydraulics of the entire system.

7.15.5.1.3 Hose shall be stored in an arrangement that will permit immediate use and shall be protected against the weather.

#### 7.15.5.2 Electric Power Supply and Connections.

7.15.5.2.1 Power supply and connections needed for operation of the generator shall be capable of transmitting the required power and shall be selected for the intended use.

7.15.5.2.2 All power cables shall be sufficiently rugged to withstand abuse in service, shall be impervious to water, and shall contain a ground wire.

7.15.5.2.3 Electrical connectors shall be waterproof.

7.15.6\* **Training.** All personnel shall be properly trained in the operation of portable foam-generating equipment and in the necessary firefighting techniques.

## Chapter 8 Compressed Air Foam Systems

### 8.1 General.

8.1.1 This chapter shall provide requirements for the correct use of compressed air foam system components.

8.1.2 All components shall be listed for their intended use.

8.1.2.1 Where listings for components do not exist, components shall be approved.

### 8.2 Water Supplies.

#### 8.2.1 Quality.

8.2.1.1 The water supply to compressed air foam systems shall be permitted to be hard or soft, fresh or salt, but shall be of a quality so that adverse effects on foam formation or foam stability do not occur.

8.2.1.2 No corrosion inhibitors, emulsion breaking chemicals, or any other additives shall be present without prior consultation with the foam concentrate supplier.

#### 8.2.2 Quantity.

8.2.2.1 The water supply shall be of a quantity to supply all the discharge devices and compressed air foam hoses that shall be permitted to be used simultaneously for the specified time.

8.2.2.2 This quantity of water shall include not only the volume required for the compressed air foam apparatus but also water that shall be permitted to be used in other firefighting operations, in addition to the normal plant requirements.

8.2.3 **Pressure.** The pressure available at the inlet to the compressed air foam system under required flow conditions shall be at least the minimum pressure for which the system has been designed.

8.2.4 **Temperature.** Water temperatures shall be between 40°F (4°C) and 100°F (38°C).

8.2.5 **Design.** The water system shall be designed and installed in accordance with NFPA 24.

8.2.6 **Storage.** Water supply shall be protected against freezing in climates where freezing temperatures are expected.

### 8.3 Foam Concentrate.

#### 8.3.1 Quality.

8.3.1.1 Foam concentrate shall be listed.

8.3.1.2 The foam concentrate used in a compressed air foam system shall be that listed for use with the equipment.

8.3.1.2.1 The performance of the system shall be dependent on the composition of the foam concentrate as listed with associated fuels and protection storage arrangement (consult applicable standard for storage arrangement protection).

8.3.1.2.2 The quality of the concentrate for proper performance under the installation requirements of this standard shall be determined by suitable tests.

8.3.2 **Quantity.** The amount of foam concentrate in the system shall be at least sufficient for the largest single hazard protected, or a group of hazards that are to be protected simultaneously.

#### 8.3.3 Storage Tanks.

8.3.3.1 Storage tanks shall be of corrosion-resisting materials and construction compatible with the foam concentrate.

8.3.3.1.1 Consideration shall be given to design of the storage tanks to minimize evaporation of concentrate.

8.3.3.2 Markings shall be provided on storage tanks to identify the type of concentrate and its intended concentration in solution.

8.3.4 **Storage Conditions.** Foam concentrate shall be stored within the listed temperature limitations.

#### 8.3.5 Reserve Supply of Foam Concentrate.

8.3.5.1 A reserve supply of foam concentrate sufficient to meet system design requirements shall be provided in order to put the system back into service after operation.

8.3.5.2 The reserve supply shall be in separate tanks or compartments, in drums or cans on the premises, or available from an approved outside source within 24 hours.

#### 8.3.6 Compatibility of Foam Concentrate.

8.3.6.1 Different types of foam concentrates shall not be mixed for storage.

8.3.6.2 Different brands of the same type of concentrate shall not be mixed unless data are provided by the manufacturer to prove that they are compatible and are accepted by the AHJ.

### 8.4 Air or Nitrogen Supply.

#### 8.4.1 Quantity.

8.4.1.1 **Primary Supply.** The amount of air or nitrogen shall be at least sufficient for the largest single hazard protected, or a group of hazards that are to be protected simultaneously.

**8.4.1.2 Reserve Supply.** A reserve supply of air or nitrogen sufficient to meet system design requirements shall be provided in order to put the system back into service after operation or available from an approved outside source within 24 hours.

#### **8.4.2 Storage Containers.**

**8.4.2.1** Storage containers shall be listed.

**8.4.2.2** Pressurized storage containers shall be designed to comply with all transportation requirements from the point of origin to the destination.

**8.4.2.2.1** Containers shall be designed, fabricated, inspected, certified, and stamped in accordance with Section VIII of ASME *Boiler and Pressure Vessel Code*.

**8.4.2.3** Pressurized storage containers shall not be located where they are subject to severe weather conditions or to mechanical, chemical, or other damage.

**8.4.2.4** Each pressurized storage container shall be provided with a releasing device.

**8.4.3 Supervision.** Air or nitrogen pressure shall be supervised for high and low pressure.

**8.4.4 Regulators.** Regulators controlling the air or nitrogen pressure for compressed air foam systems shall be listed for the intended purpose.

**8.4.5 Plant Air.** Plant air shall be permitted to be utilized where the facility has an air supply that complies with the requirements of a dedicated main and reserve air supply, including the quality, quantity, pressure, and reliability requirements of the listing, and shall be subject to the approval of the AHJ.

**8.4.6 Air Compressor.** Air compressors used as a dedicated source of air supply shall be listed for use on fire protection systems.

**8.5 Compressed Air Foam-Generating Method.** The method used to generate compressed air foam shall be listed.

#### **8.6 Distribution Systems.**

**8.6.1 Piping.** Pipe shall be in accordance with 4.7.2.3.

**8.6.2 Fittings.** All pipe fittings shall be in accordance with 4.7.3.

#### **8.7 Compressed Air Foam Discharge Devices.**

**8.7.1** Compressed air foam discharge devices shall be listed for the intended purpose.

**8.7.2** Discharge devices shall be located and installed so that they are not subject to mechanical, chemical, climatic, or other conditions that would render them inoperative.

#### **8.8 Operation and Control of Systems.**

**8.8.1** Operation and control of systems shall be in accordance with Section 4.9.

#### **8.9 System Types.**

**8.9.1** Compressed air foam systems conforming to this chapter shall be fixed deluge-type systems, fixed spray-type systems, or fixed or semi-fixed pipe Type II and Type III applications, wherein compressed air foam shall discharge simultaneously from all nozzles or devices upon system activation.

**8.9.2** The system shall be permitted to be designed to protect a single zone or multiple zones.

#### **8.10 Limitations.**

**8.10.1** Compressed air foam systems shall be designed and installed in accordance with their listing for the specific hazards and protection objectives specified in the listing.

**8.10.2** These limitations are described in the manufacturer's listed design manual, which shall be part of the listing of the system.

**8.11 System Design.** The system shall be designed in accordance with the manufacturer's design manual, which shall be part of the listing.

**8.12 Installation of Piping and Fittings.** Piping for compressed air foam systems shall be installed in accordance with NFPA 13.

**8.13 Installation of Automatic Detection.** Automatic detection devices shall be installed in accordance with NFPA 72.

#### **8.14 CAFS Discharge Device Choice and Location.**

**8.14.1** Discharge devices shall be of the type listed for the intended purpose.

**8.14.2** Discharge devices shall be located in accordance with listing limitations on spacing, floor coverage, and alignment.

**8.15 Discharge Density.** The design discharge density shall be in accordance with the applicable occupancy standards and in accordance with the manufacturer's listing but in no case less than 0.04 gpm/ft<sup>2</sup> (1.63 mm/min) for hydrocarbon fuel applications and 0.06 gpm/ft<sup>2</sup> (2.3 mm/min) for alcohol and ketone applications.

**8.15.1** Where fixed spray-type systems are used to protect three-dimensional equipment, the minimum density shall be applied over the projected area of rectangular prism envelope for the equipment and its appurtenances.

#### **8.16 Discharge Duration.**

**8.16.1** The system shall be designed to discharge compressed air foam for a minimum period of 10 minutes over the entire area for deluge-type systems and a minimum of 5 minutes for fixed spray-type systems and shall be in accordance with the manufacturer's listing.

**8.16.2** Back-up fire sprinkler protection shall be permitted to be applied as required by the AHJ.

#### **8.17 System Flow Calculation.**

**8.17.1 General.** Compressed air foam flow involves a mixture of both hydraulic and pneumatic elements, which shall be addressed together in the system design to preserve the foam bubble structure until foam is discharged on a hazard.

**8.17.2** System flow calculations shall be performed using a calculation method for compressed air foam within the limitations of the manufacturer's design manual.

**8.17.3** No calculations shall be required for a listed pre-engineered system design using the manufacturer's listed design manual.

**8.17.4** Compressed air foam piping lengths and configurations of fittings and nozzles shall be in accordance with the manufacturer's listed limitations.

**8.18 Plans and Specifications.** Plans and specifications shall be in accordance with Chapter 9.

**8.19 Testing and Acceptance.** Compressed air foam systems shall be tested in accordance with Chapter 12.

**8.20 Maintenance.** Compressed air foam systems shall be maintained in accordance with Chapter 13.

## Chapter 9 Specifications and Plans

**9.1\* Approval of Plans.** Plans shall be submitted to the AHJ for approval before installation or modification to an existing system.

**9.1.1** Deviation from approved plans shall require permission of the AHJ.

**9.2 Specifications.** Specifications for foam systems shall be developed and shall include the requirements of 9.2.1 through 9.2.3.

**9.2.1** The specifications shall designate the AHJ and shall indicate whether submission of plans is required.

**9.2.2** The specifications shall state that the installation shall conform to this standard and shall meet the approval of the AHJ.

**9.2.3\*** The specifications shall include the specific tests required to meet the approval of the AHJ.

### 9.3 Plans.

**9.3.1** Preparation of plans shall be entrusted only to fully experienced and responsible persons.

**9.3.2** These plans shall be drawn to an indicated scale or shall be dimensioned.

**9.3.3** The plans shall include or be accompanied by the following information, where applicable:

- (1) Name of owner and occupant
- (2) Location, including street address
- (3) Point of compass
- (4) Full height cross section, or schematic diagram, including structural member information construction of dike and tank
- (5) Size of supply main and whether dead end or circulating — if dead end, direction and distance to nearest circulating main — and water flow test results and system elevation relative to test hydrant
- (6) Other sources of water supply with pressure or elevation
- (7) Make, type, model, and model number of discharge devices
- (8) Pipe type and schedule of wall thickness
- (9) Nominal pipe size and cutting lengths of pipe (or center-to-center dimensions).
- (10) Types of fittings and joints, and locations of all welds and bends. The contractor shall specify on drawing any sections to be shop welded and types of fittings or formations to be used.

- (11) Types and locations of hangers, sleeves, braces, and methods of securing foam chambers or other discharge devices when applicable
- (12) All control valves, check valves, drain pipes, and test connections
- (13) Piping provisions for flushing
- (14) For hydraulically designed systems, the information on the hydraulic data nameplate
- (15) Graphic representations of the scale used on all plans
- (16) Name and address of contractor
- (17) Hydraulic reference points shown on the plan that correspond with comparable reference points on the hydraulic calculation sheets
- (18) Information about backflow preventers (manufacturer, size, type)
- (19) Sizes and locations of hydrants, showing sizes and numbers of outlets and whether outlets are to be equipped with independent gate valves. Whether hose houses and equipment are to be provided, and by whom, shall be indicated. Static and residual hydrants that were used in flow tests shall be shown
- (20) Sizes, locations, and piping arrangements of fire department connections
- (21) Physical details of the hazard, including the location, arrangement, and hazardous materials involved
- (22) Type and percentage of foam concentrate
- (23) Required solution application rate
- (24) Submergence volume calculations
- (25) Water requirements
- (26) Calculations specifying required amount of concentrate
- (27)\* Hydraulic calculations
- (28) Calculation specifying required amount of air
- (29) CAFS flow calculations report
- (30) Identification and capacity of all equipment and devices
- (31) Location of piping, detection devices, operating devices, generators, discharge outlets, and auxiliary equipment
- (32) Schematic wiring diagram
- (33) Explanations of any special features

**9.3.4** Complete plans and detailed data describing pumps, drivers, controllers, power supply, fittings, suction and discharge connections, and suction conditions shall be submitted by the engineer or contractor to the AHJ for approval before installation.

**9.3.5** Where field conditions necessitate any change affecting system performance from the approved plan, revised "as installed" plans shall be supplied for approval to the AHJ.

**9.3.6** Charts that specify head, delivery, efficiency, and brake horsepower curves of pumps shall be furnished by the contractor.

### 9.3.7 Hydraulic Calculations.

**9.3.7.1 General.** Hydraulic calculations shall be prepared on forms that include a summary sheet, detailed worksheets, and a graph sheet.

**9.3.7.2 Summary Sheet.** The summary sheet shall contain the following information, where applicable:

- (1) Date
- (2) Location
- (3) Name of owner and occupant
- (4) Building number or other identification
- (5) Description of hazard
- (6) Name and address of contractor or designer



- (7) Name of approving authority
- (8) System design requirements, as follows:
  - (a) Design area of foam application, ft<sup>2</sup> (m<sup>2</sup>)
  - (b) Minimum rate of foam
  - (c) Application, gpm/ft<sup>2</sup> [mm/min or gpm (L/m)] per outlet
  - (d) Protected area per foam chamber or discharge device, ft<sup>2</sup> (m<sup>2</sup>)
  - (e) Duration of foam application (min)
- (9) Total foam requirements as calculated, including allowance for inside hose, outside hydrants, and exposure protection (such as dike area protection)
- (10)\* Actual discharge conditions, as follows:
  - (a) Total actual foam application, gpm (L/min)
  - (b) Duration of foam application (min)
- (11) Allowable flow range of each proportioner

**9.3.7.3 Detailed Worksheets.** Detailed worksheets or computer printouts shall contain the following information:

- (1) Sheet number
- (2) Foam chamber or discharge device description and discharge constant (*K*)
- (3) Hydraulic reference points
- (4) Flow in L/min (gpm)
- (5) Pipe size
- (6) Pipe lengths, center-to-center of fittings
- (7) Equivalent pipe lengths for fittings and devices
- (8) Friction loss in psi/ft (bar/m) of pipe
- (9) Total friction loss between reference points
- (10) Elevation head in psi (bar) between reference points
- (11) Required pressure in psi (bar) at each reference point
  - Velocity pressure and normal pressure if included in calculations
- (12) Notes to indicate starting points or reference to other sheets or to clarify data shown

**9.3.7.4 Graph Sheet.** A graphic representation of the complete hydraulic calculation shall be plotted on semi-exponential graph paper ( $Q^{1.85}$ ) and shall include the following:

- (1) Water supply curve
- (2) Foam system demand
- (3) Hose allowance, where applicable

**9.3.7.5 Water Supply Analysis.** Summarized information regarding the available water supply shall include the following information:

- (1) Node tag at the source
- (2) Static pressure [psi (bar)] available at the source
- (3) Residual pressure [psi (bar)] available at the source
- (4) Total flow [gpm (bar)] available at the source
- (5) Available water pressure [psi (bar)] at the source when the total calculated demand is flowing
- (6) Total calculated water demand [gpm (L/m)] at the source
- (7) Required pressure [psi (bar)] at the source when flowing total calculated demand
- (8) Total water flow rate [gpm (L/m)] at the source, balanced to the available water supply
- (9) Balanced pressure [psi (bar)] at the source when flowing total water flow rate.

## Chapter 10 Installation Requirements

### 10.1 Foam Concentrate Pumps.

**10.1.1** Foam concentrate pump discharge pressure shall not exceed the working pressure of the concentrate piping or components in the system.

**10.1.2** Positive displacement pumps and centrifugal pumps are capable of overpressuring the system and shall be provided with means of pressure relief from the discharge to the supply side of the circuit to prevent excessive pressure and temperature.

### 10.2 Flushing.

**10.2.1** Pumps shall be provided with a means for flushing with water.

**10.2.2** Foam concentrate piping systems shall be provided with flush inlet and outlet connections.

### 10.3 Power Supply.

**10.3.1** Power supply for the drivers of foam concentrate pumps shall be installed in accordance with NFPA 20 and NFPA 70.

**10.3.2** Power supplies shall be arranged such that disconnecting power from the protected facility during a fire does not disconnect the power supply to the foam concentrate pump feeder circuit.

### 10.3.3 Controller.

**10.3.3.1** A controller governing the start-up of foam concentrate pumps with electric drivers of 30 horsepower or less shall be listed as a limited service controller.

**10.3.3.2** A controller governing the start-up of foam concentrate pumps with electric drivers of greater than 30 horsepower shall be listed as a full service fire pump controller.

**10.3.3.3** A controller governing the start-up of foam concentrate pumps with diesel engine drivers shall be listed as a diesel engine fire pump controller.

### 10.3.4\* Service Disconnecting Means.

**10.3.4.1** A service disconnecting means in the feeder circuits to limited service controllers shall be permitted, where allowed by the AHJ, provided the disconnecting means is supervised for the correct position.

**10.3.4.2** Supervision for correct position shall be performed by one of the following:

- (1) Central station, proprietary, or remote station signaling electrical supervision service
- (2) Local electrical supervision through use of a signaling service that will cause the sounding of an audible signal at a constantly attended point
- (3) Locking the disconnect in the correct position with monthly recorded inspections

### 10.4 Low-Expansion System Piping.

**10.4.1** All piping inside of dikes or within 50 ft (15 m) of tanks not diked shall be buried under at least 12 in. (300 mm) of earth or, if aboveground, shall be supported and protected against mechanical injury.

**10.4.2\*** For systems that apply foam to a tank's liquid surface from the top side, all piping within the dike or within 50 ft (15 m) of tanks not diked shall be designed to absorb the upward force and shock caused by a tank roof rupture.

**10.4.3\*** One flange or union joint shall be provided in each riser at a convenient location, preferably directly below the foam maker, to permit hydrostatic testing of the piping system up to this joint.

**10.4.4** Hose connections for semi-fixed foam systems on fixed-roof (cone) tanks shall terminate outside the dike area at least one tank diameter from the tank but in no case less than 50 ft (15 m).

**10.4.5** The inlets to the piping shall be fitted with corrosion-resistant metal connections, compatible with the equipment supplying foam solution to the system, and provided with plugs or caps.

### 10.5 Valves in Low-Expansion Systems.

**10.5.1** The laterals to each foam discharge outlet on fixed roof tanks shall be separately valved outside the dike in the following circumstances:

- (1) All fixed systems
- (2) Any laterals of a semi-fixed system not supplied by an individual hose connection

**10.5.1.1** Valves shall be located either in the central foam station or at points where the laterals branch from the common supply line.

**10.5.1.2** These valves shall not be located within the dike.

**10.5.1.3** Valves shall be located at a distance of at least one tank diameter from the tank but in no case less than 50 ft (15 m).

**10.5.1.4** Shutoff valves shall be permitted to be located at shorter distances where remotely operated, subject to the approval of the AHJ.

**10.5.2** Where two or more foam proportioners are installed in parallel and discharge into the same outlet header, valves shall be provided between the outlet of each device and the header.

**10.5.3** The water line to each proportioner inlet shall be separately valved.

**10.5.4** For subsurface applications, each foam delivery line shall be provided with a valve and a check valve unless the latter is an integral part of the high back-pressure foam maker or pressure generator to be connected at the time of use.

**10.5.5** Where product lines are used for foam, product valving shall be arranged to ensure that foam enters only the tank to be protected.

**10.5.6** Drain valves that are accessible shall be provided for low points in underground and aboveground piping.

### 10.5.7\* Bladder Tank Valves.

**10.5.7.1** For bladder tank systems with multiple risers, the water supply feed to the bladder tank shall be arranged to prevent the discharge of foam concentrate into risers that have been isolated, to prevent further discharge into the hazard.

**10.5.7.2** For single-riser systems, the water feed to the bladder tank shall be located above the system control valve.

### 10.6 Hangers, Supports, and Protection for Pipework.

**10.6.1** Where protecting hazards where there is a possibility of explosion, pipework shall be routed to afford the best protection against damage.

**10.6.2** The supply piping to foam outlets that protect a given hazard in a fire area shall not pass over another hazard in the same fire area.

**10.6.3** All hangers shall be of approved types.

**10.6.4** Tapping or drilling of load-bearing structural members shall not be permitted where unacceptable weakening of the structure would occur.

**10.6.5** Attachments shall be made to existing steel or concrete structures and equipment supports.

**10.6.6** Where systems are of such a design that the standard method of supporting pipe for protection purposes cannot be used, the piping shall be supported in such a manner as to produce the strength equivalent to that afforded by the standard means of support.

**10.7 Hose Requirements.** Unlined fabric hose shall not be used with foam equipment.

**10.8 Test Connections.** Valves and hose connections shall be installed to facilitate testing of proportioning equipment.

**10.8.1** A ½ in. (15 mm) female National Pipe Thread (FNPT) threaded connection for a pressure gauge shall be provided at the most remote fixed foam discharge outlet.

**10.8.2** The ½ in. (15 mm) connection for foam makers and foam chambers shall be installed 2 to 4 pipe diameters upstream of the discharge device inlet.

**10.8.3** Where galvanized piping is used in accordance with 4.7.2.2, the threaded connection shall be installed on the spool piece prior to being treated to prevent localized corrosion at the connection.

## Chapter 11 Low-Expansion Foam Systems for Marine Applications

### 11.1\* General.

**11.1.1** This chapter shall cover design information for the use of low-expansion foam systems that are necessary for marine applications where required by the AHJ.

**11.1.2** The provisions of Chapters 4, 5, 7, and 9 of this standard shall not be applicable unless specifically referenced.

### 11.1.3\* Components.

**11.1.3.1** All components shall be listed or approved for their intended application and shall be approved for use in a marine environment.

**11.1.3.2** Each manufacturer shall maintain a system design manual describing basic system design arrangements and denoting each of the manufacturers' products within the system.

**11.1.4** Foam concentrates shall be approved.

**11.1.4.1** The concentrate used in a foam system for protecting a flammable or combustible liquid shall be approved for hydro-

carbons in accordance with a test method equivalent to the 100 ft<sup>2</sup> (9.3 m<sup>2</sup>) hydrocarbon method given in Annex F.

**11.1.4.2** Four consecutive fire tests shall be completed — two using sea water and two using freshwater.

**11.1.4.3\*** Concentrates intended for use on polar solvent systems shall be approved for hydrocarbons in accordance with 11.1.4.1 and approved for use on polar solvents in accordance with a method comparable to UL 162.

**11.1.5** The foam supply shall conform to the requirement of 4.3.2.2.

**11.1.6** The water supply shall conform to the requirements of 4.2.1.1 through 4.2.1.3.

**11.1.7** The foam system shall be capable of being actuated, including introduction of foam solution into the foam main within 3 minutes of notification of a fire.

## **11.2 Fixed Low-Expansion Foam Systems for Machinery Spaces.**

**11.2.1\*** Where installed, systems protecting machinery spaces shall be capable of discharging the required quantity of expanded foam to provide a foam depth of at least 6 in. (150 mm) over the largest area over which oil is expected to spread.

**11.2.2** The foam solution application rate shall be in accordance with either of the following:

- (1) Product listing
- (2) Approval by the AHJ

**11.2.2.1** The minimum foam solution application rate shall be 0.16 gpm/ft<sup>2</sup> (6.5 mm/min) for a minimum of 5 minutes.

**11.2.3** The system shall be capable of generating foam for extinguishing hydrocarbon fires.

**11.2.4** Means shall be provided for effective distribution of the foam through a permanent system of piping and control valves to discharge outlets and for foam to be directed by fixed foam outlets.

**11.2.5** The foam expansion ratio shall not exceed 12:1.

**11.2.6** Where a deck foam system is also installed, the foam supply and proportioning system shall not be required to be separate.

**11.2.7** The quantity of foam concentrate shall be that required to meet the single largest system demand.

### **11.2.8 Controls.**

**11.2.8.1** System controls shall be simple to operate and grouped together in a location accessible during fire conditions in the protected area.

**11.2.8.2** Instructions in permanent lettering shall be affixed to the equipment or in a position adjacent thereto.

**11.2.8.3** Remotely controlled devices shall have local mechanical override.

## **11.3 Fixed Low-Expansion Foam Systems on Deck for Petroleum and Chemical Tankers.**

**11.3.1\* Purpose.** The purpose of this section shall be to provide guidance for the design and arrangement of deck

foam systems that are expected to provide the following performance:

- (1) Extinguish deck spill fires and maintain a foam blanket while hot metal cools.
- (2) Control or suppress cargo manifold fires except those involving three-dimensional pressurized liquid fires.
- (3) Suppress or control tank fires involving a portion of the cargo area, assuming that the top of the tank(s) within the design area is open to weather and that the trajectory of the foam is not obstructed.
- (4) Provide protection for the crew while arrangements are being made to abandon ship.
- (5) During lightering operations, the deck foam system flowing water shall protect the exposed vessel from fire on an adjacent ship while preparations are made to get the exposed vessel under way.
- (6) The deck foam system is not intended to provide extinguishment, suppression, or control of incidents resulting from major explosions or collisions that cause the fire to exceed the area of the single largest tank.
- (7) The deck foam system shall be designed and arranged to withstand the effects of weather, vibration, corrosion, strain, and impact expected during the ship's operation.
- (8) Suppress vapors from an unignited spill on deck.

### **11.3.2 Control Station.**

**11.3.2.1** The main control station for the system shall be located aft of the cargo area and be operable in the event of fire in the main area protected.

**11.3.2.2\*** Operating instructions and diagrams of piping systems and valves shall be provided in clear and permanent lettering and shall be affixed to the equipment or in a position visible thereto.

**11.3.2.2.1** The diagrams shall show which valves are to be opened in the event the system must be activated.

**11.3.2.2.2** The diagrams shall explain thoroughly and clearly all the steps necessary to put the system into operation.

**11.3.2.2.3** Each valve shall be labeled describing its function.

**11.3.2.3** The control station shall be provided with emergency lighting.

**11.3.3\* Fire Main Capacity.** Operation of a deck foam system at its required foam solution flow rate shall still permit the simultaneous use of the required number of streams of water and other services provided by the fire main system.

**11.3.4\* Rate of Application.** The rate of application of foam solution for fires on deck shall not be less than the greatest of 11.3.4.1 or 11.3.4.2.

**11.3.4.1** Rate of application for hydrocarbon fuels shall be in accordance with the product listing or approved by the AHJ but in no case less than the following:

- (1) Deck spill calculation: 0.16 gpm/ft<sup>2</sup> (6.50 mm/min) over 10 percent of the cargo block deck area, where the cargo block deck area is the maximum breadth of the ship multiplied by the total longitudinal extent of the cargo tank spaces
- (2) Largest tank calculation: 0.24 gpm/ft<sup>2</sup> (9.78 mm/min) of the horizontal sectional area of the single largest tank
- (3) Largest monitor calculation: 0.074 gpm/ft<sup>2</sup> (3.0 mm/min) of the area protected by the largest monitor, such

area being entirely forward of the monitor, but not less than 330 gpm (1250 L/min)

**11.3.4.2** Rate of application for polar solvents shall be as follows:

- (1) Since required foam application rates are permitted to vary, polar solvents are placed in representative groups based upon fire performance tests.
- (2) Fire tests are used to determine the minimum foam design application rate for the group and are conducted using one or more solvents representing the most difficult extinguishment case or the actual polar solvent.
- (3) The following minimum foam design application rates and polar solvent groupings shall be specified in the foam manufacturer's system design manual and shall be approved:
  - (a) Deck spill calculation: the highest required foam application rate for any polar solvent that is permitted to be transported by the ship, applied over 10 percent of the cargo block deck area, where the cargo block deck area is the maximum breadth of the ship multiplied by the total longitudinal extent of the cargo tank spaces
  - (b) Most demanding tank calculation: 150 percent of the highest required foam application rate, for any polar solvent that is permitted to be transported by the ship, applied over the horizontal sectional area of the single largest tank
  - (c) Where dedicated cargo tanks are specifically designed for a particular polar solvent and such solvent is not permitted to be carried in other tanks, the foam system design is permitted to take into consideration this limitation.
  - (d) Largest monitor calculation: 45 percent of the highest required foam application rate for any polar solvent that is permitted to be transported by the ship, applied over the area protected by the foam monitor, such area being entirely forward of the monitor, but not less than 330 gpm (1250 L/min)

### 11.3.5 Discharge Duration.

**11.3.5.1\*** Foam concentrate shall be provided to supply the system for 30 minutes.

**11.3.5.2** For ships that are both transporting only hydrocarbons and using gas inerting of cargo vapor spaces, the discharge duration shall be permitted to be 20 minutes.

**11.3.5.3** Allowance shall be made to fill all foam solution and concentrate piping and still provide the required duration.

**11.3.5.4\*** Minimum discharge duration shall be based on the actual capacity of the installed equipment.

### 11.4\* Foam Outlet Devices.

**11.4.1** One hundred percent of the required foam application shall be by using one or two monitors located immediately aft of the protected area.

**11.4.2** On tankers less than 4000 metric tons dead weight, hand hoses only shall be permitted to be installed in lieu of monitors specified in 11.4.1, provided that the capacity of each hand hose is at least 25 percent of the total foam solution flow rate.

### 11.5 Monitors.

**11.5.1** The capacity of any monitor shall be at least 0.074 gpm/ft<sup>2</sup> (3.02 mm/min) of the deck area protected by that monitor, with such area being entirely forward of the monitor.

**11.5.2** The capacity of each monitor shall be not less than 50 percent of the required foam application rate and not less than 330 gpm (1250 L/min).

**11.5.3** The distance from the monitor to the farthest extremity of the protected area forward of the monitor shall be not more than 75 percent of the monitor throw in still air conditions.

**11.5.4** Foam monitors and hand hose connections shall be situated both port and starboard at the front of the accommodation space facing the cargo tanks deck.

**11.5.5** If provided, these monitors shall be located at least 8.2 ft (2.5 m) above the main deck and shall be directly accessible to the deck above the freeboard deck.

**11.5.6** The foam system shall be capable of delivering foam to the entire cargo block deck area.

**11.5.6.1** Ships fitted with bow or stern loading and unloading arrangements shall be provided with one or more additional monitors located to protect the bow or stern arrangements.

**11.5.6.2** The area of the cargo line fore or aft of the cargo block area shall be provided with monitor protection.

**11.5.6.3** Foam monitors shall be mounted on platforms.

**11.5.6.4** Platforms shall permit 360-degree access around the monitors.

**11.5.6.5** Platforms shall be raised to allow the monitors an unobstructed throw insofar as practical.

**11.5.6.6** The monitor isolation valve shall be accessible from the monitor platform.

**11.5.6.7** Platforms higher than 6.5 ft (2 m) shall be provided with handrails or chain rails.

**11.5.6.8** Access to the monitor platform shall be via walkway or permanent ladder.

**11.5.6.9** Provisions shall be made for securing monitors while at sea.

### 11.5.7 Monitors.

**11.5.7.1** Monitors over 1000 gpm (3800 L/min) shall be provided with two operator handholds or one handwheel for each swivel.

**11.5.7.2** Monitors shall be designed to prevent unwanted movement due to reaction forces.

**11.5.7.3** Monitors shall be capable of being locked into position while operating at full flow.

### 11.6 Hand Hoses.

**11.6.1** Hand hoses shall be provided to ensure flexibility of action during firefighting operations and to cover areas obstructed from monitors.

**11.6.2** The capacity of any hand hoseline shall be not less than 100 gpm (380 L/min), and the hand hoseline throw in still air conditions shall be not less than 50 ft (15 m).

**11.6.3** The number and location of foam solution outlets shall be such that foam from at least two hand hoselines shall be permitted to be simultaneously directed onto any part of the cargo block deck area.

**11.6.4** Hand hoselines and hydrants shall be mounted on monitor platforms or at deck level.

### **11.7 Hydraulic Calculations.**

**11.7.1** Hydraulic calculations shall be performed in accordance with NFPA 15. Foam solution shall be considered to have the same hydraulic characteristics as water.

**11.7.2** Foam concentrate hydraulic calculations shall be performed in accordance with the foam concentrate manufacturer's system design manual.

**11.7.3** Orifices shall be permitted to balance flows to monitors and fixed foam outlets for marine applications.

### **11.8 Isolation Valves.**

**11.8.1** Isolation valves shall be provided in the water, foam concentrate, and foam solution mains (immediately forward of any monitor position) to isolate damaged sections. In addition, each monitor and hose station shall have an isolation valve.

**11.8.2** Isolation valves shall be operable from accessible locations.

**11.8.3** Monitor isolation valves shall be in accordance with 11.5.6.3 through 11.5.6.9.

**11.8.4** All isolation valves shall be installed with the bonnet above the horizontal.

**11.8.5** Isolation valves shall be provided with a ready means for visual indication of valve position.

### **11.9 Hangers, Supports, and Protection of Pipework.**

**11.9.1** Pipework shall be routed to afford protection against damage.

**11.9.2\*** All hangers and piping supports shall be designed for marine applications.

**11.9.3\*** Deck foam solution piping shall be independent of fire main piping.

**11.9.4** Where the fire main and foam main are connected to a common monitor, check valves shall be installed.

**11.9.5\*** The system shall be arranged to prevent the possibility of freezing.

**11.9.5.1** Portions of the system exposed to weather shall be self-draining.

**11.9.5.2** Wet or pressurized portions of the system shall be protected against freezing.

### **11.10 Testing and Inspection.**

**11.10.1\*** Foam systems shall be inspected and tested in accordance with Chapters 11 and 12.

**11.10.2** Annual testing shall include tests conducted in accordance with Section 12.6.

**11.10.3** The system supplier or owner shall provide to the ship's crew a system use, inspection, and testing videotape.

### **11.11 Foam System Concentrate Storage.**

**11.11.1** Foam concentrate storage shall be in compliance with 4.3.2.4.

**11.11.1.1\*** The primary deck foam concentrate storage tank shall be located on or above the freeboard deck level in the space containing the system control station described in 11.3.2.

**11.11.1.2** All foam concentrate shall be stored in an accessible location unlikely to be cut off in the event of fire or explosion and not having direct opening or exposure to the cargo area.

**11.11.2** Foam concentrate tanks shall be in compliance with 4.3.2.3.

**11.11.2.1\*** Tanks shall have expansion domes.

**11.11.2.2** Tanks shall be fitted with baffles to prevent sloshing.

**11.11.2.3** Each concentrate storage tank shall be provided with a brass, stainless steel, or other corrosion-resistant pressure vacuum (PV) vent.

**11.11.2.4** Each tank shall have a support structure for mounting the tank to the ship's structure.

**11.11.2.5** Each tank shall have a sump or other means to prevent clogging of the foam concentrate suction pipe in the event of sedimentation or other foreign materials in the tank.

**11.11.2.6** The foam concentrate suction pipe shall take suction above the bottom of the sump.

**11.11.3** Tanks shall be of a design and materials designed for constant sloshing of the liquid against the tank structure.

**11.11.4** Each tank shall have a manway or openings for internal inspection and access.

**11.11.5** Tank suction and return connections shall terminate near the bottom of the tank so as to reduce the chance of premature foaming due to agitation during system operation.

**11.11.6** Atmospheric tanks shall be provided with means for continuous refilling of the tank.

**11.11.7** Foam concentrate storage shall be within the foam concentrate manufacturer's recommended temperature limitations.

**11.11.7.1** Storage spaces shall be provided with heat to prevent freezing of the foam concentrate and piping.

**11.11.7.2** Storage shall be in compliance with 4.3.2.4 and 4.3.2.4.1.

**11.11.8** Foam concentrate compatibility shall be in compliance with 4.4.1 and 4.4.2. The foam concentrate storage tank shall be provided with a label specifying foam manufacturer, foam type, and quantity.

**11.11.9** Only one type of foam concentrate shall be carried on board.

### **11.12 Supply Arrangements.**

**11.12.1\*** Foam proportioning shall be by the balanced pressure proportioning method employing a dedicated foam concentrate pump.

**11.12.2** Other types of systems acceptable to the AHJ shall be permitted.

**11.12.3\*** Foam concentrate pumps shall be in compliance with Section 4.6.

**11.12.4\*** Foam and water pump motors and controllers shall comply with IEEE 45 or equivalent.

**11.12.5** Foam and water pumps shall be capable of operation during loss of the main power system.

**11.12.6** Electric power for foam pumps, water pumps, and other electrical components of the foam system shall be in accordance with the provisions of 4.3 and 4.3.5 of SOLAS Regulations II-2 applicable to fire pumps.

**11.12.7** Where diesel pumps are provided, they shall be connected to a listed diesel pump controller.

**11.12.8** The deck foam system piping shall not be routed through, immediately adjacent to, or immediately above the cargo pump room.

### **11.13 Piping Materials.**

**11.13.1** Piping shall be in compliance with Section 4.7, except as provided in 11.13.1.1.

**11.13.1.1** Unprotected carbon steel pipe shall not be used for foam solution piping.

**11.13.2** Pipe in areas subject to fire exposure, including radiant and conducted heat, shall be of steel or other alloy rated for the pressure, possible fire temperature exposure, and environmental conditions expected.

**11.13.3** Foam concentrate piping shall be constructed of material compatible with, and not affected by, the concentrate.

**11.13.4** Foam concentrate piping shall not be galvanized.

**11.13.5\*** Pipe thread joint sealants used for foam concentrate lines shall be in compliance with the foam concentrate manufacturer's recommendations.

**11.13.6** When foam solution piping is assembled using unprotected steel pipe and fittings, it shall be hot-dip galvanized after fabrication.

**11.13.7** Where pipe and fittings are galvanized, all disturbed areas shall be repaired using a cold galvanizing product.

## **Chapter 12 Acceptance Testing**

### **12.1 Inspection and Visual Examination.**

**12.1.1** Foam systems shall be examined visually to determine that they have been installed in accordance with approved plans and specifications.

**12.1.2** Foam systems shall be inspected for such items as conformity with installation plans; continuity of piping; removal of temporary blinds; accessibility of valves, controls, and gauges; and proper installation of vapor seals, where applicable.

**12.1.3** Devices shall be checked for identification and operating instructions.

### **12.2 Flushing after Installation.**

**12.2.1** In order to remove foreign materials that have entered both underground and aboveground water supply mains during installation, the water supply mains shall be flushed thoroughly at the maximum practicable rate of flow before connection is made to system piping.

**12.2.2** The minimum rate of flow for flushing shall not be less than the water demand rate of the system, as determined by the system design.

**12.2.3** The flow shall be continued to ensure thorough cleaning.

**12.2.4** All foam system piping shall be flushed after installation, using the system's normal water supply with foam-forming materials shut off, unless the hazard cannot be subjected to water flow.

**12.2.5** Where flushing cannot be accomplished, pipe interiors shall be visually examined for cleanliness during installation.

**12.2.5.1** All compressed air foam system piping interiors shall be carefully visually examined and, if necessary, cleaned during installation of the pipe.

**12.2.5.2** Compressed air foam system piping shall be flushed after installation, using the system's air supply in lieu of flushing with water.

### **12.3\* Acceptance Tests.**

**12.3.1** The completed system shall be tested by qualified personnel to meet the approval of the AHJ.

**12.3.2** These tests shall be used to determine that the system has been installed in accordance with approved plans and specifications, and that it functions as intended.

### **12.4 Pressure Tests.**

**12.4.1** All piping, except piping handling expanded foam for other than subsurface application, shall be subjected to a 2-hour hydrostatic pressure gauge test at 200 psi (1379 kPa) or 50 psi (345 kPa) in excess of the maximum pressure anticipated, whichever is greater, in accordance with NFPA 13.

**12.4.2** Drainage pitch for all normally dry horizontal piping shall be verified.

### **12.5 Operating Tests.**

**12.5.1** Before acceptance, all operating devices and equipment shall be tested for function.

**12.5.2** Tests for total flooding systems shall establish that all automatic closing devices for doors, windows, and conveyor openings, and automatic equipment interlocks, as well as automatic opening of heat and smoke vents or ventilators, will function upon system operation.

**12.5.3** Tests shall include a complete check of electrical control circuits and supervisory systems to ensure operation and supervision in the event of failure.

### **12.5.4 Water Supply Test.**

**12.5.4.1** The main drain valve shall be opened and remain open until the system residual pressure stabilizes.

**12.5.4.2** The static and residual pressures shall be recorded on the contractor's material and test certificate.

**12.5.5 Operating Test for Control Valves.** All control valves shall be fully closed and opened under system water pressure to ensure proper operation.

**12.5.6** Operating instructions provided by the supplier and device identification shall be verified.

#### **12.6\* Discharge Tests.**

**12.6.1** Where conditions permit, flow tests shall be conducted to ensure that the hazard is fully protected in conformance with the design specification.

**12.6.2** The concentration of the foam solution sample shall be verified by one of the following measurement devices:

- (1)\* Digital refractometer
- (2)\* Digital electric conductivity
- (3) Listed digital flow meters (total flow and foam concentrate)
- (4) Other means acceptable to the AHJ

**12.6.3\*** The following data shall be required:

- (1) Static water pressure
- (2) Residual water pressure at the control valve and at a remote reference point in the system
- (3) Actual discharge rate
- (4) Consumption rate of foam-producing material
- (5) Concentration of the foam solution

**12.6.3.1** For compressed air foam systems, the following data shall be recorded as part of any discharge test:

- (1) Static water pressure
- (2) Residual water pressure at the control valve
- (3) System air pressure
- (4) Concentration of the foam solution

**12.6.4\*** The foam proportioning system shall be permitted to be tested with a listed or approved method that does not require discharge of foam concentrate. (*See Annex D.*)

**12.6.5** The foam concentrate induction rate of a proportioner, expressed as a percentage of the foam solution flow (water plus foam concentrate), shall be within minus 0 percent to plus 30 percent of the manufacturer's listed concentrations, or plus 1 percentage point, whichever is less. For information tests for physical properties of foam, see Annex D.

**12.7 Approval of Low-, Medium-, and High-Expansion Foam Systems.** The installing contractor shall perform the following tasks:

- (1) Notify the AHJ and the property owner or the property owner's authorized representative of the time and date testing will be performed
- (2) Perform all acceptance tests required by this chapter
- (3)\* Complete and sign the contractor's material and test certificate for low-, medium-, and high-expansion foam systems

**12.8 System Restoration.** After acceptance tests are completed, the system shall be flushed and restored to operational condition.

#### **12.9 Acceptance Tests of Foam-Water Deluge and Spray Systems.**

##### **12.9.1\* Flushing of Supply Piping.**

**12.9.1.1** Underground mains and lead-in connections shall be thoroughly flushed before connection is made to the system piping.

**12.9.1.2** Flushing shall be in accordance with NFPA 24.

##### **12.9.2 Hydrostatic Pressure Tests.**

**12.9.2.1\*** All piping, including foam concentrate lines and the system piping, shall be hydrostatically tested at 200 psi (13.8 bar) or at 50 psi (3.5 bar) in excess of the maximum static pressure where the maximum static pressure exceeds 150 psi (10.3 bar).

**12.9.2.1.1** The pressure shall be maintained without loss for 2 hours.

**12.9.2.1.2** Bladder tanks shall not be included in pressure tests.

**12.9.2.2 Underground Piping Systems.** Underground water piping shall be tested in accordance with NFPA 24.

##### **12.9.3 System Tests Discharging Foam from Foam-Water Deluge and Spray Systems.**

###### **12.9.3.1\* Acceptance Tests.**

**12.9.3.1.1 Approval of Systems.** The installing contractor shall perform the following:

- (1) Notify the AHJ and the property owner or the property owner's authorized representative of the time and date testing will be performed.
- (2) Perform all required acceptance tests.
- (3) Complete and sign the contractor's material and test certificate (*see Figure 12.9.3.1.1*).
- (4) Remove all temporary system components such as caps and straps prior to placing the system in service.

**12.9.3.1.2** Acceptance tests shall be conducted to ensure that the hazard is fully protected in accordance with Chapter 4 and to determine the flow pressures, actual discharge capacity, consumption rate of foam-producing materials, staffing needs, and other operating characteristics.

**12.9.3.1.3** The tests shall include the following:

- (1) Foam discharge from a single system
- (2) Simultaneous foam discharge of the maximum number of systems expected to operate on a single hazard

**12.9.3.1.4** The discharge shall be continued for the time required to obtain stabilized discharge.

###### **12.9.4\* Proportioning System Testing.**

**12.9.4.1** Operation of the proportioning equipment shall be verified by flow tests.

**12.9.4.1.1** For closed (wet pipe, preaction, or dry pipe) systems, the concentration shall be verified by flow tests at the actual calculated discharge demand for the least hydraulically demanding condition and at the minimum design flow rate of the system. For open deluge systems, the concentration shall be verified by flow tests at the midrange design flow rate of the system.

<b>Sample Contractor's Material and Test Certificate for Foam-Water Sprinkler/Spray System</b>								
<b>PROCEDURE</b> Upon completion of work, inspection and tests shall be made by the contractor's representative and witnessed by the property owner or their authorized agent. All defects shall be corrected and system left in service before contractor's personnel finally leave the job.  A certificate shall be filled out and signed by both representatives. Copies shall be prepared for approving authorities, owners, and contractor. It is understood the owner's representative's signature in no way prejudices any claim against contractor for faulty material, poor workmanship, or failure to comply with approving authority's requirements or local ordinances.								
Property name					Date			
Property address								
Plans	Accepted by approving authorities (names)							
	Address							
	Installation conforms to accepted plans				<input type="checkbox"/> Yes	<input type="checkbox"/> No		
Equipment used is approved				<input type="checkbox"/> Yes	<input type="checkbox"/> No			
If no, explain deviations								
Instructions	Has person in charge of fire equipment been instructed as to location of control valves and care and maintenance of this new equipment? If no, explain				<input type="checkbox"/> Yes	<input type="checkbox"/> No		
	Have copies of the following been left on the premises?				<input type="checkbox"/> Yes	<input type="checkbox"/> No		
	1. System components instructions				<input type="checkbox"/> Yes	<input type="checkbox"/> No		
	2. Care and maintenance instructions				<input type="checkbox"/> Yes	<input type="checkbox"/> No		
3. NFPA 25				<input type="checkbox"/> Yes	<input type="checkbox"/> No			
Location of system	Supplies buildings							
Sprinklers or Nozzles	Make	Model	Year of manufacture	Orifice size	Quantity	Temperature rating		
Pipe and fittings	Type of pipe _____ Type of fittings _____							
<b>General</b> Building type: <input type="checkbox"/> New <input type="checkbox"/> Existing <input type="checkbox"/> Renovation      Area: _____ Construction type: <input type="checkbox"/> Fire resistive <input type="checkbox"/> Noncombustible <input type="checkbox"/> Ordinary <input type="checkbox"/> Heavy timber <input type="checkbox"/> Wood frame <input type="checkbox"/> Mixed								
Occupancy classification: _____								
<b>Foam-water system type</b> <input type="checkbox"/> Wet <input type="checkbox"/> Dry <input type="checkbox"/> Preaction <input type="checkbox"/> Deluge <input type="checkbox"/> Spray <input type="checkbox"/> Preprimed								
Sprinkler omitted in any areas?		<input type="checkbox"/> Yes	<input type="checkbox"/> No					
Spare sprinkler provided?		<input type="checkbox"/> Yes	<input type="checkbox"/> No					
Sprinkler wrench provided?		<input type="checkbox"/> Yes	<input type="checkbox"/> No					
Area of coverage:		<input type="checkbox"/> Total	<input type="checkbox"/> Partial	<input type="checkbox"/> Special hazard	<input type="checkbox"/> Other			
<b>Fire Pump</b> Fire pump provided? <input type="checkbox"/> Yes <input type="checkbox"/> No If yes, rated capacity: _____ gpm @ _____ psi Type of pump: <input type="checkbox"/> Electric <input type="checkbox"/> Diesel <input type="checkbox"/> Steam								
© 2020 National Fire Protection Association						NFPA 11 (p. 1 of 3)		

FIGURE 12.9.3.1.1 Contractor's Material and Test Certificate for Foam-Water Sprinkler/Spray System.



<b>Hydrostatic test</b>									
All piping tested at _____ psi for _____ hours									
Dry piping pneumatically tested?					<input type="checkbox"/> Yes		<input type="checkbox"/> No		
Equipment operates properly?					<input type="checkbox"/> Yes		<input type="checkbox"/> No		
Do you certify as the installing contractor that additives and corrosive chemicals, sodium silicate, brine, or other corrosive chemicals were not used for testing systems or stopping leaks?					<input type="checkbox"/> Yes		<input type="checkbox"/> No		
<b>Main drain test</b>									
Static pressure _____ psi					Residual pressure _____ psi				
Backflow device forward flow test		Indicate means used for forward flow test of backflow device: _____							
		When means to test device was opened, was system flow demand created? <input type="checkbox"/> Yes <input type="checkbox"/> No <input type="checkbox"/> N/A							
<b>Alarm valve or flow indicator</b>									
Alarm device							Minimum time to operate through test connection		
Type	Make		Model		Minutes	Seconds			
<b>Dry pipe operating test</b>									
Dry valve					Q.O.D.				
Make		Model		Serial no.	Make		Model	Serial no.	
Time to trip through test connection		Water pressure		Air pressure	Trip point air pressure		Time water reached test outlet		Alarm operated properly
Minutes Seconds		psi		psi	psi		Minutes Seconds		Yes No
Without Q.O.D.									
With Q.O.D.									
<b>Deluge and preaction valves</b>									
Operation <input type="checkbox"/> Pneumatic <input type="checkbox"/> Electric <input type="checkbox"/> Hydraulic									
Piping supervised? <input type="checkbox"/> Yes <input type="checkbox"/> No					Detecting media supervised? <input type="checkbox"/> Yes <input type="checkbox"/> No				
Does valve operate from the manual trip, remote, or both control actions?					<input type="checkbox"/> Yes <input type="checkbox"/> No				
Is there an accessible facility in each circuit for testing? <input type="checkbox"/> Yes <input type="checkbox"/> No					If no, explain.				
Make		Model		Does each circuit operate supervision loss alarm?		Does each circuit operate valve release?		Maximum time to operate release?	
				Yes No		Yes No		Minutes Seconds	
<b>Foam system concentrate tests</b>									
High flow rate _____ gpm @ _____ psi					Results fall within -0% to +30% for balanced pressure system: <input type="checkbox"/> Yes <input type="checkbox"/> No				
Low flow rate _____ gpm @ _____ psi					Results fall within -0% to +30% for balanced pressure system: <input type="checkbox"/> Yes <input type="checkbox"/> No				
For positive pressure systems with pump or pressure controlled bladder tank and inline balanced pressure type proportioning systems: -0% to +30% or greater:					<input type="checkbox"/> Yes <input type="checkbox"/> No				
Foam concentrate induction rate -0% to +30% of manufacturer's listed induction rate or 1 percentage point, whichever is less, at listed flow rates:					<input type="checkbox"/> Yes <input type="checkbox"/> No				
Balanced pressure proportioning systems produce the minimum percentage of manufacturer's requirements -0% at minimum listed flow rate:					<input type="checkbox"/> Yes <input type="checkbox"/> No				
Positive pressure proportioning with pumps or pressure-controlled bladder tanks produce the maximum percentage of manufacturer's requirement +30% or 1 percentage point, whichever is less, at the minimum listed flow rate:					<input type="checkbox"/> Yes <input type="checkbox"/> No				
Variable pressure orifice type proportioners produce the percentage -0% to +30% or 1 percentage point, whichever is less:					<input type="checkbox"/> Yes <input type="checkbox"/> No				
Foam discharge was collected and disposed of properly:					<input type="checkbox"/> Yes <input type="checkbox"/> No				
Approved simulated foam concentrates were used for this test:					<input type="checkbox"/> Yes <input type="checkbox"/> No				
Type _____									
All foam residue was removed from the piping system by flushing with clean water:					<input type="checkbox"/> Yes <input type="checkbox"/> No				
© 2020 National Fire Protection Association					NFPA 11 (p. 2 of 3)				

FIGURE 12.9.3.1.1 Continued

Hydraulic data nameplate	Nameplate provided	If no, explain	
	<input type="checkbox"/> Yes <input type="checkbox"/> No		
Date left in service with all control valves open:			
<b>Tests witnessed by</b>			
Owner / Authorized Agent		Title	Date
Contractor		Title	Date
Additional explanations and notes			
<div style="display: flex; justify-content: space-between;"> <span>© 2020 National Fire Protection Association</span> <span>NFPA 11 (p. 3 of 3)</span> </div>			

**FIGURE 12.9.3.1.1** *Continued*

**12.9.4.1.1.1** For open deluge systems, the concentration shall be verified by flow tests at the actual calculated discharge demand.

**12.9.4.1.1.2** Foam flow tests shall include a minimum flow test for wet pipe, dry pipe, and preaction systems equal to the flow of the most remote (4) sprinklers.

**12.9.4.1.2** During the tests the pressure at the proportioning devices shall be at the design operating pressure of the system or systems tested.

**12.9.4.1.3** The percentage of all foam concentrates injected into the water at their listed flow rates shall be within the limits given in 12.9.4.1.4.

**12.9.4.1.4** The foam concentrate induction rate of a proportioner, expressed as a percentage of the foam solution flow (water plus foam concentrate), shall be within minus 0 percent to plus 30 percent of the manufacturer's listed concentration, or plus 1 percentage point, whichever is less.

**12.9.4.1.4.1** Full-flow testing of the proportioning system and discharge device shall be required to properly evaluate the proportioning system.

**12.9.4.1.4.2** For balanced pressure and positive pressure proportioning systems, flow tests shall be permitted to be conducted through the test connections required in 6.4.10.

**12.9.4.1.4.3** For positive-pressure proportioning with pumps or pressure-controlled bladder tanks the percentage at minimum listed flow shall be at the maximum percentage of manufacturer's requirement plus 30 percent, or 1 percentage point, whichever is less.

**12.9.4.1.4.4** For variable orifice type proportioners the percentage shall be minus 0 percent and plus 30 percent or 1 percentage point, whichever is less.

**12.9.4.1.4.5** For balanced pressure and positive pressure proportioning systems, flow tests shall be permitted to be conducted through the test connections required in 6.4.10. For other proportioning system types, full-flow testing of system and discharge devices is required to properly evaluate the proportioning system.

**12.9.4.1.4.6** Flow tests for wet pipe, dry pipe, and preaction systems shall be conducted at the low end of the listed design flow rate of the proportioning equipment and shall meet the criteria of 12.9.4.1.4.

**12.9.4.1.5** When performing foam system proportioning tests the discharge foam solution shall be collected and disposed of by either the owner, the owner's representative, or the installing contractor in accordance with the requirements of the AHJ.

**12.9.4.1.6** The one-time recycling of discharged foam solution to preprime the system, if collected in a manner that will prevent contamination, and if in accordance with the design criteria of the applicable standards, shall be permitted.

**12.9.4.1.7** Where approved by the AHJ, simulated foam concentrates or alternative test systems shall be permitted to be substituted for actual foam concentrate, but system pressures and flows shall remain as described above and meet manufacturer's system requirements and recommendations.

**12.9.4.2 Rate of Discharge.**

**12.9.4.2.1** The rate of foam solution discharge shall be computed from hydraulic calculations utilizing recorded inlet or end-of-system operating pressure, or both.

**12.9.4.2.2\*** The foam concentration shall be calculated by a refractometric means, a conductivity method, or other approved methods.

**12.9.4.3 Flushing the System.**

**12.9.4.3.1\*** After operation with foam, foam-water deluge and spray systems shall be flushed with water to remove foam residue.

**12.9.4.3.2** Those portions of the system normally containing foam concentrate when the system is in service shall not be required to be flushed.

**12.9.5 Instructions.** The installing contractors shall provide the owner with the following:

- (1) All literature and instructions provided by the manufacturer describing proper operation and maintenance of any equipment and devices installed
- (2) Piping layout drawings, electrical schematics, and hydraulic calculations
- (3) NFPA 25

**12.9.6 Hydraulic Design Information Sign.**

**12.9.6.1** The installing contractor shall identify a hydraulically designed sprinkler system with a permanently marked weatherproof metal or rigid plastic sign secured with corrosion-resistant wire, chain, or other approved means. [13:28.5.1]

**12.9.6.2** Such signs shall be placed at the alarm valve, dry pipe valve, preaction valve, or deluge valve supplying the corresponding hydraulically designed area. [13:28.5.2]

**12.9.6.3** The sign shall include the following information:

- (1) Location of the design area or areas
- (2) Discharge density over the design area or areas
- (3) Required flow and residual pressure of the most hydraulically demanding calculation
- (4) Required flow and pressure of the least hydraulically demanding calculation
- (5) Discharge duration of foam solution
- (6) Hose stream allowance included in addition to the sprinkler demand
- (7) The name of the installing contractor

**12.9.7\* General Information Sign.**

**12.9.7.1** The installing contractor shall provide a general information sign used to determine system design basis and information relevant to the inspection, testing, and maintenance requirements required by NFPA 25. [13:28.6.1]

**12.9.7.1.1** Such general information shall be provided with a permanently marked weatherproof metal or rigid plastic sign, secured with corrosion-resistant wire, chain, or other acceptable means. [13:28.6.1.1]

**12.9.7.1.2** Such signs shall be placed at each system control riser and auxiliary system control valve.

**12.9.7.2** The sign shall include the following information:

- (1) Name and location of the facility protected

- (2) Occupancy classification
- (3) Commodity classification
- (4) Presence of high-piled and/or rack storage
- (5) Maximum height of storage planned
- (6) Aisle width planned
- (7) Encapsulation of pallet loads
- (8) Presence of solid shelving
- (9) Flow test data
- (10) Presence of flammable/combustible liquids
- (11) Presence of hazardous materials
- (12) Presence of other special storage
- (13) Location of venting valve
- (14) Location of auxiliary drains and low point drains on dry pipe and preaction systems
- (15) Original results of main drain flow test
- (16) Original results of dry pipe and double interlock preaction valve test
- (17) Name of installing contractor or designer
- (18) Indication of presence and location of antifreeze or other auxiliary systems
- (19) Where injection systems are installed to treat MIC or corrosion, the type of chemical, concentration of the chemical, and where information can be found as to the proper disposal of the chemical
- (20) Foam concentrate type and percent concentration

**Chapter 13 Inspection, Testing, and Maintenance****13.1 General.****13.1.1 Minimum Requirements.**

**13.1.1.1\*** This chapter shall provide the minimum requirements for the routine inspection, testing, and maintenance of low-, medium-, and high-expansion foam, as well as foam-water sprinkler systems.

**13.1.1.2** Table 13.1.1.2 shall be used to determine the minimum required frequencies for inspection, testing, and maintenance. [25:11.1.1.2]

**13.1.2 Other System Components.** Fire pumps, water storage tanks, common components, and valves common to other types of water-based fire protection systems shall be inspected, tested, and maintained in accordance with Chapters 8, 9, and 13, respectively [of NFPA 25], and as specified in Table 13.1.1.2. [25:11.1.2]

**13.1.3** Alarm and detection devices shall be tested and inspected in accordance with *NFPA 72*.

**13.1.4** Systems shall be so arranged that tests and inspections can be made without discharging foam solution to the system piping in order to check operation of all mechanical and electrical components of the system.

**13.1.5\*** The system shall be arranged so that tests are performed with as little loss of foam concentrate as possible.

**13.1.6\*** If during routine inspection and testing the system is determined to have been altered or replaced, it shall be determined whether the system operates properly.

**13.1.7** All persons who are expected to inspect, test, maintain, or operate apparatus shall be thoroughly trained, and training shall be kept current.

**Table 13.1.1.2 Summary of Foam-Water Sprinkler System Inspection, Testing, and Maintenance**

System/Component	Frequency	Reference [NFPA 25]
<b>Inspection</b>		
Control valve(s)		Chapter 13
Deluge/preaction valve(s)		Chapter 13
Discharge device location (spray nozzle)	Monthly	11.2.4
Discharge device location (sprinkler)	Annually	11.2.4
Discharge device position (spray nozzle)	Monthly	11.2.4
Discharge device position (sprinkler)	Annually	11.2.4
Drainage in system area	Quarterly	11.2.7
Fire pump system		Chapter 8
Fittings corrosion	Annually	11.2.2
Fittings damage	Annually	11.2.2
Foam concentrate strainer(s)	Quarterly	11.2.6.4
Gauges		Chapter 13
Hangers/braces/supports	Annually	11.2.3
Pipe corrosion	Annually	11.2.2
Pipe damage	Annually	11.2.2
Proportioning system(s) — all	Monthly	11.2.8
Strainer(s) — Mainline	5 years	11.2.6.1
Water supply piping		11.2.5.1
Water supply tank(s)		Chapter 9
Waterflow alarm devices		Chapter 13
<b>Test</b>		
Backflow preventer(s)		Chapter 13
Complete foam-water sprinkler system(s) (operational test)	Annually	11.3.2, 11.3.3
Control valve(s)		Chapter 13
Deluge/preaction valve(s)		Chapter 13
Discharge device location	Annually	11.3.2.6
Discharge device obstruction	Annually	11.3.2.6
Discharge device position	Annually	11.3.2.6
Fire pump system		Chapter 8
Foam-water solution	Annually	11.3.5

(continues)

**Table 13.1.1.2 Continued**

System/Component	Frequency	Reference [NFPA 25]
Manual actuation device(s)	Annually	11.3.4
Valve status test		Chapter 13
Water supply flow test		Chapter 7
Water supply tank(s)		Chapter 9
Waterflow alarm devices		Chapter 13
<b>Maintenance</b>		
Backflow preventer(s)		Chapter 13
Bladder tank type		
Foam concentrate tank — hydrostatic test	10 years	11.4.5.2
Sight glass	10 years	11.4.5.1
Check valve(s)		Chapter 13
Control valve(s)		Chapter 13
Deluge/preaction valves		Chapter 13
Detector check valve(s)		Chapter 13
Fire pump system		Chapter 8
Foam concentrate pump operation	Monthly	11.4.7.1
Foam concentrate samples	Per manufacturer's recommendation	11.4.2
Foam concentrate strainer(s)	Quarterly	Section 11.4
In-line balanced pressure type		
Balancing valve diaphragm	5 years	11.4.8.3
Foam concentrate pump(s)	5 years*	11.4.8.2
Foam concentrate tank	10 years	11.4.8.4
Line type		
Foam concentrate tank — corrosion and pickup pipes	10 years	11.4.6.2
Foam concentrate tank — drain and flush		
Pressure vacuum vents	5 years	11.4.9
Proportioning system(s) standard pressure type		
Ball drip (automatic type)	5 years	11.4.4.1
drain valves		
Corrosion and hydrostatic test	10 years	11.4.4.4

(continues)

Table 13.1.1.2 *Continued*

System/Component	Frequency	Reference [NFPA 25]
Foam concentrate tank — drain and flush	10 years	11.4.4.2
Standard balanced pressure type		
Balancing valve diaphragm	5 years	11.4.7.3
Foam concentrate pump(s)	5 years*	11.4.7.2
Foam concentrate tank	10 years	11.4.7.4
Strainer(s) — mainline	5 years	11.2.6.1
Water supply	Annually	11.2.5.2
Water supply tank(s)		Chapter 9

\*Also refer to manufacturer's instructions and frequency. Maintenance intervals other than preventive maintenance are not provided, as they depend on the results of the visual inspections and operational tests. For foam-water sprinkler systems in aircraft hangars, refer to the inspection, test, and maintenance requirements of Table 11.1.1 in NFPA 409.

[25:Table 11.1.1.2]

## 13.2 Low-, Medium-, and High-Expansion Foam Systems.

### 13.2.1\* General.

**13.2.1.1** At least annually, all foam systems shall be thoroughly inspected and tested for correct operation.

**13.2.1.2** The goal of this inspection and testing shall be to ensure that the system is in full operating condition and that it remains in that condition until the next inspection.

**13.2.1.3** The inspection report, with recommendations, shall be filed with the owner.

**13.2.1.4** Between the regular service contract inspections or tests, the system shall be inspected by competent personnel following an approved schedule.

### 13.2.2\* Foam-Producing Equipment.

**13.2.2.1** Proportioning devices, their accessory equipment, and foam makers shall be inspected.

**13.2.2.2** Fixed discharge outlets equipped with frangible seals shall be provided with inspection means to permit maintenance and for inspection and replacement of vapor seals.

**13.2.2.2.1\*** At least annually, water shall be discharged through each foam maker discharge outlet to confirm that foam makers and foam solution feed lines are not obstructed by debris.

**13.2.2.2.2\*** Alternative methods where approved by the AHJ shall be permitted.

**13.2.2.3\*** Proportioning equipment shall be tested annually in accordance with Section 13.2.6.

### 13.2.2.4 Compressed Air Foam-Producing Equipment.

**13.2.2.4.1** Compressed air foam-generating equipment and accessories shall be inspected annually.

**13.2.2.4.2** Discharge devices shall be visually inspected annually for evidence of mechanical damage.

### 13.2.3 Piping.

**13.2.3.1** Aboveground piping shall be examined to determine its condition and to verify that proper drainage pitch is maintained.

**13.2.3.2** Pressure tests of normally dry piping shall be made when visual inspection indicates questionable strength due to corrosion or mechanical damage.

**13.2.3.3** Underground piping shall be spot-checked for deterioration at least every 5 years.

**13.2.4 Strainers.** Strainers shall be inspected in accordance with manufacturer's instructions and shall be cleaned after each use and flow test.

**13.2.5 Detection and Actuation Equipment.** Control valves, including all automatic and manual-actuating devices, shall be tested at regular intervals.

### 13.2.6 Foam Concentrate Inspection.

**13.2.6.1** At least annually, an inspection shall be made of foam concentrates and their tanks or storage containers for evidence of excessive sludging or deterioration.

**13.2.6.2** Samples of concentrates shall be sent to the manufacturer or qualified laboratory for quality condition testing.

**13.2.6.3** When the foam type and brand of foam are known, the quality testing shall confirm the product meets the manufacturer's specifications.

**13.2.6.4** Quantity of concentrate in storage shall meet design requirements, and tanks or containers shall normally be kept full, with space allowed for expansion.

**13.2.7 High-Pressure Cylinders.** High-pressure cylinders used in compressed air foam systems shall not be recharged without a hydrostatic test (and remarking) if more than 5 years have elapsed from the date of the last test. Cylinders that have been in continuous service without discharging shall be permitted to be retained in service for a maximum of 12 years, after which they shall be discharged and retested before being returned to service.

**13.2.8 Operating Instructions and Training.** Operation, system deactivation, and maintenance instructions and layouts shall be posted at control equipment with copies of each on file.

## 13.3 Foam-Water Sprinkler Systems.

### 13.3.1 General.

**13.3.1.1\*** If during routine inspection and testing the foam-water sprinkler system is determined to have been altered or replaced (e.g., equipment replaced, relocated, or foam concentrate replaced), it shall be determined whether the system operates properly. [25:11.1.4.1]

**13.3.1.2 Obstruction Investigations.** The procedures outlined in Chapter 14 [of NFPA 25] shall be followed where there is a need to conduct an obstruction investigation. [25:11.1.5]

**13.3.1.3 Impairments.** The procedures outlined in Chapter 15 [of NFPA 25] shall be followed where an impairment to protection occurs. [25:11.1.6]

**13.3.1.4 System Piping and Fittings.** System piping and fittings shall be inspected for the following:

- (1) Mechanical damage (e.g., broken piping or cracked fittings)
- (2) External conditions (e.g., missing or damaged paint or coatings, rust, and corrosion)
- (3) Misalignment or trapped sections
- (4) Low-point drains (automatic or manual)
- (5) Location and condition of rubber-gasketed fittings [25:11.2.2]

**13.3.1.5 Hangers, Braces, and Supports.** Hangers, braces, and supports shall be inspected for the following and repaired or replaced as necessary:

- (1) Condition (e.g., missing or damaged paint or coating, rust, and corrosion)
- (2) Secure attachment to structural supports and piping
- (3) Damaged or missing hangers, braces, and supports [25:11.2.3]

### 13.3.2 Inspection.

#### 13.3.2.1\* Foam-Water Discharge Devices.

**13.3.2.1.1** Foam-water discharge devices shall be inspected visually and maintained to ensure that they are in place, continue to be aimed or pointed in the direction intended in the system design, and are free from external loading and corrosion. [25:11.2.4.1]

**13.3.2.1.2** Where caps or plugs are required, the inspection shall confirm they are in place and free to operate as intended. [25:11.2.4.2]

**13.3.2.1.3** Misaligned discharge devices shall be adjusted (aimed) by visual means, and the discharge patterns shall be inspected at the next scheduled flow test. [25:11.2.4.3]

**13.3.2.1.4\*** Inspection shall verify that unlisted combinations of discharge devices and foam concentrate have not been substituted. [25:11.2.4.4]

#### 13.3.2.2 Water Supply.

**13.3.2.2.1** The dependability of the water supply shall be ensured by regular inspection and maintenance, whether furnished by a municipal source, on-site storage tanks, a fire pump, or private underground piping systems. [25:11.2.5.1]

**13.3.2.2.2\*** Water supply piping shall be maintained free of internal obstructions. [25:11.2.5.2]

#### 13.3.2.3 Strainers.

**13.3.2.3.1** Mainline and individual discharge device strainers (basket or screen) shall be inspected every 5 years for damaged and corroded parts. [25:11.2.6.1]

**13.3.2.3.2** Other maintenance intervals shall be permitted, depending on the results of the visual inspection and operating tests. [25:11.2.6.2]

**13.3.2.3.3** Discharge device strainers shall be removed, inspected, and cleaned during the flushing procedure for the mainline strainer. [25:11.2.6.3]

**13.3.2.3.4** Foam concentrate strainers shall be inspected visually to ensure the blowdown valve is closed and plugged. [25:11.2.6.4]

**13.3.2.3.5** Baskets or screens shall be removed and inspected after each operation or flow test. [25:11.2.6.5]

**13.3.2.4 Drainage.** The area beneath and surrounding a foam-water spray system shall be inspected to ensure that drainage facilities, such as trap sumps and drainage trenches, are not blocked, and retention embankments or dikes are in good repair. [25:11.2.7]

#### 13.3.2.5\* Proportioning Systems.

**13.3.2.5.1** The components of the various proportioning systems described in 13.3.2.5 shall be inspected in accordance with the frequency specified in Table 13.1.1.2. [25:11.2.8.1]

**13.3.2.5.2** Valves specified to be inspected shall be permitted to be open or closed, depending on specific functions within each foam-water sprinkler system. [25:11.2.8.2]

**13.3.2.5.3** The position (open or closed) of valves shall be verified in accordance with specified operating conditions. [25:11.2.8.3]

**13.3.2.5.4\*** Inspection of the concentrate tank shall include verification that the quantity of foam concentrate satisfies the requirements of the original design. [25:11.2.8.4]

**13.3.2.5.5** Additional inspection requirements shall be performed as detailed for the proportioning systems specified in 13.3.2.5. [25:11.2.8.5]

##### 13.3.2.5.5.1 Standard Pressure Proportioner.

**(A)\*** The pressure shall be removed before the inspection to prevent injury. [25:11.2.8.5.1.1]

**(B)** The inspection shall verify the following:

- (1) Ball drip valves (automatic drains) are free and opened.
- (2) External corrosion on foam concentrate storage tanks is not present. [25:11.2.8.5.1.2]

##### 13.3.2.5.5.2 Bladder Tank Proportioner.

**(A)\*** The pressure shall be removed before the inspection to prevent injury. [25:11.2.8.5.2.1]

**(B)** The inspection shall include the following:

- (1) Water control valves to foam concentrate tank
- (2) An inspection for external corrosion on foam concentrate storage tanks
- (3) An inspection for the presence of foam in the water surrounding the bladder (annual) [25:11.2.8.5.2.2]

**13.3.2.5.5.3 Line Proportioner.** The inspection shall include the following:

- (1)\* Strainers
- (2)\* Verification that pressure vacuum vent is operating freely
- (3) An inspection for external corrosion on foam concentrate storage tanks [25:11.2.8.5.3]

**13.3.2.5.5.4 Standard Balanced Pressure Proportioner.** The inspection shall include the following:

- (1)\* Strainers
- (2)\* Verification that pressure vacuum vent is operating freely
- (3) Verification that gauges are in good operating condition
- (4) Verification that sensing line valves are open
- (5) Verification that power is available to foam liquid pump [25:11.2.8.5.4]

**13.3.2.5.5.5 In-Line Balanced Pressure Proportioner.** The inspection shall include the following:

- (1)\* Strainers
- (2)\* Verification that pressure vacuum vent is operating freely
- (3) Verification that gauges are in good working condition
- (4) Verification that sensing line valves at pump unit and individual proportioner stations are open
- (5) Verification that power is available to foam liquid pump [25:11.2.8.5.5]

**13.3.2.5.5.6 Orifice Plate Proportioner.** The inspection shall include the following:

- (1)\* Strainers
- (2)\* Verification that pressure vacuum vent is operating freely
- (3) Verification that gauges are in good working condition
- (4) Verification that power is available to foam liquid pump [25:11.2.8.5.6]

**13.3.3\* Operational Tests.** Frequency of system tests shall be in accordance with Table 13.1.1.2. [25:11.3]

**13.3.3.1\* Test Preparation.** Precautions shall be taken to prevent damage to property during the test. [25:11.3.1]

**13.3.3.2\* Operational Test Performance.**

**13.3.3.2.1** Operational tests shall be conducted to ensure that the foam-water sprinkler system(s) responds as designed, both automatically and manually. [25:11.3.2.1]

**13.3.3.2.2** The test procedures shall simulate anticipated emergency events so the response of the foam-water sprinkler system(s) can be evaluated. [25:11.3.2.2]

**13.3.3.2.3** Where discharge from the system discharge devices would create a hazardous condition or conflict with local requirements, an approved alternate method to achieve full flow conditions shall be permitted. [25:11.3.2.3]

**13.3.3.2.4 Response Time.** Under test conditions, the automatic fire detection systems, when exposed to a test source, shall operate within the requirements of *NFPA 72* for the type of detector provided, and the response time shall be recorded. [25:11.3.2.4]

**13.3.3.2.5 Discharge Time.** The time lapse between operation of detection systems and water delivery time to the protected area shall be recorded for open discharge devices. [25:11.3.2.5]

**13.3.3.2.6 Discharge Patterns.**

**13.3.3.2.6.1** The discharge patterns from all of the open spray devices shall be observed to ensure that patterns are not impeded by plugged discharge devices and to ensure that discharge devices are correctly positioned and that obstructions do not prevent discharge patterns from covering surfaces to be protected. [25:11.3.2.6.1]

**13.3.3.2.6.2** Where obstructions occur, the piping and discharge devices shall be cleaned and the system retested. [25:11.3.2.6.2]

**13.3.3.2.6.3** Discharge devices shall be permitted to be of different orifice sizes and types. [25:11.3.2.6.3]

**13.3.3.2.7\* Pressure Readings.**

**13.3.3.2.7.1** Pressure readings shall be recorded at the most hydraulically demanding discharge device.

**13.3.3.2.7.2** It shall be permissible to test the full flow discharge from foam-water deluge systems using water only in lieu of foam. [25:11.3.2.7.2]

**13.3.3.2.7.3** A second pressure reading shall be recorded at the main control valve. [25:11.3.2.7.3]

**13.3.3.2.7.4** Readings shall be compared to the hydraulic design pressures to ensure the original system design requirements are met. [25:11.3.2.7.4]

**13.3.3.3 Multiple Systems.** The maximum number of systems expected to operate in case of fire shall be tested simultaneously to inspect the adequacy of the water supply and concentrate pump. [25:11.3.3]

**13.3.3.4 Manual Actuation Devices.** Manual actuation devices shall be tested annually. [25:11.3.4]

**13.3.3.5 Concentration Testing.**

**13.3.3.5.1** During the operational test, a foam sample shall be taken. [25:11.3.5.1]

**13.3.3.5.2** Where approved by the authority having jurisdiction, simulated foam concentrates or alternative test systems shall be permitted to be substituted for actual foam concentrate, but system pressures and flows shall remain as described above and meet manufacturer's system requirements and recommendations. [25:11.3.5.2]

**13.3.4\* Maintenance.**

**13.3.4.1** Maintenance of foam-water sprinkler systems shall be in accordance with the requirements of those chapters covering the specific component parts. [25:11.4.1]

**13.3.4.2 Foam Concentrate Samples.** Samples of foam concentrates shall be sent to the manufacturer or qualified laboratory for quality condition testing at the frequency recommended by the manufacturer. [25:11.4.2]

**13.3.4.3 Foam Components.** Maintenance of specific foam components shall be in accordance with 13.3.4.4 through 13.3.4.8. [25:11.4.3]

**13.3.4.4 Standard Pressure Proportioner.**

**13.3.4.4.1** The ball drip (automatic-type) drain valves shall be disassembled, cleaned, and reassembled. [25:11.4.4.1]

**13.3.4.4.2\*** The foam liquid storage tank shall be drained of foam liquid and flushed. [25:11.4.4.2]

**13.3.4.4.3** Foam liquid shall be permitted to be salvaged and reused. [25:11.4.4.3]

**13.3.4.4.4** The foam liquid tank shall be inspected for internal and external corrosion and hydrostatically tested to the specified working pressure. [25:11.4.4.4]

### 13.3.4.5 Bladder Tank Proportioner.

13.3.4.5.1 Sight glass, where provided, shall be removed and cleaned. [25:11.4.5.1]

13.3.4.5.2\* The foam concentrate bladder tank shall be hydrostatically tested at system working pressure. [25:11.4.5.2]

13.3.4.5.2.1 The hydrostatic test shall not create a pressure differential across the diaphragm. [25:11.4.5.2.1]

13.3.4.5.2.2 While under system working pressure, the exterior of the foam concentration bladder tank shall be inspected for leaks. [25:11.4.5.2.2]

### 13.3.4.6 Line Proportioner.

13.3.4.6.1 The foam concentrate tank shall be inspected for internal corrosion. [25:11.4.6.1]

13.3.4.6.2 Pickup pipes inside the tank shall be inspected for corrosion, separation, or plugging. [25:11.4.6.2]

13.3.4.6.3 The foam concentrate tank shall be drained and flushed. [25:11.4.6.3]

13.3.4.6.4 Foam concentrate shall be permitted to be salvaged and reused. [25:11.4.6.4]

### 13.3.4.7 Standard Balanced Pressure Proportioner.

#### 13.3.4.7.1 Pump Operation.

13.3.4.7.1.1 Foam concentrate shall be circulated back to the tank. [25:11.4.7.1.2]

13.3.4.7.2 **Servicing.** Foam pumps, drive train, and drivers shall be serviced in accordance with the manufacturer's instructions and frequency but not at intervals of more than 5 years. [25:11.4.7.2]

13.3.4.7.3 **Flushing.** The diaphragm balancing valve shall be flushed through the diaphragm section with water or foam concentrate until fluid appears clear or new. [25:11.4.7.3]

#### 13.3.4.7.4 Corrosion and Sediment.

13.3.4.7.4.1 The foam concentrate tank shall be inspected internally for corrosion and sediment. [25:11.4.7.4.1]

13.3.4.7.4.2 Excessive sediment shall require draining and flushing of the tank. [25:11.4.7.4.2]

### 13.3.4.8 In-Line Balanced Pressure Proportioner.

#### 13.3.4.8.1 Pump Operation.

13.3.4.8.1.1 The foam concentrate pump shall be operated. [25:11.4.8.1.1]

13.3.4.8.1.2 Foam concentrate shall be circulated back to the tank. [25:11.4.8.1.2]

13.3.4.8.2 **Servicing.** Foam pumps, drive train, and drivers shall be serviced in accordance with the manufacturer's instructions and frequency but not at intervals of more than 5 years. [25:11.4.8.2]

13.3.4.8.3 **Flushing.** The diaphragm balancing valve shall be flushed through the diaphragm section with water or foam concentrate until fluid appears clear or new. [25:11.4.8.3]

#### 13.3.4.8.4 Corrosion and Sediment.

13.3.4.8.4.1 The foam concentrate tank shall be inspected internally for corrosion and sediment. [25:11.4.8.4.1]

13.3.4.8.4.2 Excessive sediment shall require draining and flushing of the tank. [25:11.4.8.4.2]

13.3.4.9 **Pressure Vacuum Vents.** The procedures specified in 13.3.4.9.1 through 13.3.4.9.13 shall be performed on pressure vacuum vents every 5 years. [25:11.4.9]

13.3.4.9.1 The vent shall be removed from the expansion dome. [25:11.4.9.1]

13.3.4.9.2 The vent shall be inspected to ensure that the opening is not blocked and that dirt or other foreign objects do not enter the tank. [25:11.4.9.2]

13.3.4.9.3 The vent bonnet shall be removed. [25:11.4.9.3]

13.3.4.9.4 The vacuum valve and pressure valve shall be lifted out. [25:11.4.9.4]

13.3.4.9.5 The vent body shall be flushed internally, and the vacuum valve and the pressure valve shall be washed thoroughly. [25:11.4.9.5]

13.3.4.9.6 The vent shall be inspected to ensure that the screen is not clogged, and the use of any hard, pointed objects to clear the screen shall be avoided. [25:11.4.9.6]

13.3.4.9.7 If the liquid has become excessively gummy or solidified, the vent body and parts shall be soaked in hot soapy water. [25:11.4.9.7]

13.3.4.9.8 The vent body shall be turned upside down and drained thoroughly. [25:11.4.9.8]

13.3.4.9.9 Parts shall be dried by placing them in a warm and dry area or by using an air hose. [25:11.4.9.9]

13.3.4.9.10 Parts shall be sprayed with a light Teflon® coating, and the vent shall be reassembled. [25:11.4.9.10]

13.3.4.9.11 The use of any type of oil for lubrication purposes shall not be permitted. [25:11.4.9.11]

13.3.4.9.12 The vent bonnet shall be replaced, and the vent shall be turned upside down slowly a few times to ensure proper freedom of the movable parts. [25:11.4.9.12]

13.3.4.9.13 The vent shall be attached to the liquid storage tank expansion dome. [25:11.4.9.13]

### 13.3.5 Component Action Requirements.

13.3.5.1 Whenever a component in a foam-water sprinkler system is adjusted, repaired, reconditioned, or replaced, the action required in Table 13.3.5.1 shall be performed. [25:11.5.1]

13.3.5.2 Where the original installation standard is different from the cited standard, the use of the appropriate installing standard shall be permitted. [25:11.5.2]



Table 13.3.5.1 Summary of Component Action Requirements

Component	Adjust	Repair/ Recondition	Replace	Required Action
<b>Water Delivery Components</b>				
Discharge devices	X		X	(1) Inspect for leaks at system working pressure (2) Inspect for impairments at orifice
Fire department connections	X	X	X	See Chapter 13
Manual release	X	X	X	(1) Operational test (2) Inspect for leaks at system working pressure (3) Test all alarms
Pipe and fittings on closed-head system	X	X	X	Hydrostatic test in conformance with NFPA 16
Pipe and fittings on open-head system	X	X	X	Operational flow test
<b>Foam Components</b>				
Ball drip (automatic-type) drain valves				See Chapter 13
Bladder tank	X	X	X	Inspect water jacket for presence of foam concentrate
Foam concentrate	X		X	Submit a sample for laboratory analysis for conformance with manufacturer's specifications
Foam concentrate pump				See Chapter 8
Foam concentrate strainer(s)				See Chapter 13
Foam concentrate tank	X	X	X	Inspect for condition; repair as appropriate
Proportioning system(s)	X	X	X	Conduct flow test and inspect proportioning by refractometer test or equivalent
Water supply tank(s)				See Chapter 9
<b>Alarm and Supervisory Components</b>				
Detection system	X	X	X	Operational test for conformance with NFPA 16 and/or NFPA 72
Pressure-switch-type waterflow	X	X	X	Operational test using inspector's test connection
Valve supervisory device			X	Test for conformance with NFPA 16 and/or NFPA 72
Vane-type waterflow	X	X	X	Operational test using inspector's test connection
Water motor gong			X	Operational test using inspector's test connection
<b>Status-Indicating Components</b>				
Gauges	X		X	Verify at 0 psi (0 bar) and system working pressure; see Chapter 13 regarding calibration
<b>Testing and Maintenance Components</b>				
Auxiliary drains	X	X	X	Inspect for leaks at system working pressure
Inspector's test connection	X	X	X	Inspect for leaks at system working pressure
Main drain	X	X	X	Full-flow main drain test
<b>Structural Components</b>				
Hanger/seismic bracing	X	X	X	Inspect for conformance with NFPA 16 and/or NFPA 13
Pipe stands	X	X	X	Inspect for conformance with NFPA 16 and/or NFPA 13
<b>Informational Components</b>				
General information sign	X	X	X	Inspect for conformance with NFPA 16 and/or NFPA 13
Hydraulic information sign	X	X	X	Inspect for conformance with NFPA 16 and/or NFPA 13
Valve signs	X	X	X	Inspect for conformance with NFPA 16 and/or NFPA 13

[25:Table 11.5.1]

## Annex A Explanatory Material

*Annex A is not a part of the requirements of this NFPA document but is included for informational purposes only. This annex contains explanatory material, numbered to correspond with the applicable text paragraphs.*

**A.1.1** Firefighting foam is an aggregate of air-filled bubbles formed from aqueous solutions and is lower in density than flammable liquids. It is used principally to form a cohesive floating blanket on flammable and combustible liquids and prevents or extinguishes fire by excluding air and cooling the fuel. It also prevents reignition by suppressing formation of flammable vapors. It has the property of adhering to surfaces, which provides a degree of exposure protection from adjacent fires. Foam can be used as a fire prevention, control, or extinguishing agent for flammable liquid hazards. Foam for these hazards can be supplied by fixed piped systems or portable foam-generating systems. Foam can be applied through foam discharge outlets, which allow it to fall gently on the surface of the burning fuel. Foam can also be applied by portable hose streams using foam nozzles or large-capacity monitor nozzles or subsurface injection systems.

Foam can be supplied by overhead piped systems for protection of hazardous occupancies associated with potential flammable liquid spills in the proximity of high-value equipment or for protection of large areas. The foam used for flammable liquid spills is in the form of a spray or dense "snowstorm." The foam particles coalesce on the surface of the burning fuel after falling from the overhead foam outlets, which are spaced to cover the entire area at a uniform density. *(For systems required to meet both foam and water spray design criteria, see NFPA 16.)*

Large-spill flammable liquid fires can be fought with mobile equipment, such as an aircraft crash truck or industrial foam truck equipped with agent and equipment capable of generating large volumes of foam at high rates. Foam for this type of hazard can be delivered as a solid stream or in a dispersed pattern. Standards for industrial foam trucks include NFPA 1901, and standards for aircraft crash trucks include NFPA 414.

Foam does not break down readily and, when applied at an adequate rate, has the ability to extinguish fire progressively. As application continues, foam flows easily across the burning surface in the form of a tight blanket, preventing reignition on the surfaces already extinguished. Foam is not suitable for three-dimensional flowing liquid fuel fires or for gas fires.

To determine where foam protection is required, see applicable standards such as NFPA 30. Foam can be applied to protect the surface of a flammable liquid that is not burning. The foam concentrate manufacturer should be consulted to determine the optimum method of application, rate of discharge, application density, and frequency of reapplication required to establish and maintain the integrity of the foam blanket.

**A.1.1.2** The final decision on what foam protection should be provided will be a site-specific decision based on the local operating conditions, the requirements of the AHJ, and the associated risk to safety, the environment, asset loss, and ongoing business. These factors could justify higher levels of risk reduction than those required by the AHJ.

**A.3.2.1 Approved.** The National Fire Protection Association does not approve, inspect, or certify any installations, proce-

dures, equipment, or materials; nor does it approve or evaluate testing laboratories. In determining the acceptability of installations, procedures, equipment, or materials, the authority having jurisdiction may base acceptance on compliance with NFPA or other appropriate standards. In the absence of such standards, said authority may require evidence of proper installation, procedure, or use. The authority having jurisdiction may also refer to the listings or labeling practices of an organization that is concerned with product evaluations and is thus in a position to determine compliance with appropriate standards for the current production of listed items.

**A.3.2.2 Authority Having Jurisdiction (AHJ).** The phrase "authority having jurisdiction," or its acronym AHJ, is used in NFPA documents in a broad manner, since jurisdictions and approval agencies vary, as do their responsibilities. Where public safety is primary, the authority having jurisdiction may be a federal, state, local, or other regional department or individual such as a fire chief; fire marshal; chief of a fire prevention bureau, labor department, or health department; building official; electrical inspector; or others having statutory authority. For insurance purposes, an insurance inspection department, rating bureau, or other insurance company representative may be the authority having jurisdiction. In many circumstances, the property owner or his or her designated agent assumes the role of the authority having jurisdiction; at government installations, the commanding officer or departmental official may be the authority having jurisdiction.

**A.3.2.4 Listed.** The means for identifying listed equipment may vary for each organization concerned with product evaluation; some organizations do not recognize equipment as listed unless it is also labeled. The authority having jurisdiction should utilize the system employed by the listing organization to identify a listed product.

**A.3.3.2 Concentration.** The type of foam concentrate used determines the percentage of concentration required. For example, a 3 percent foam concentrate is mixed in the ratio of 97 parts water to 3 parts foam concentrate to make foam solution.

**A.3.3.3 Discharge Devices.** Examples include, but are not limited to, sprinklers, spray nozzles, and hose nozzles.

**A.3.3.3.3 Non-Air-Aspirating Discharge Devices.** When discharging AFFF or FFFP solution, they generate an effective AFFF or FFFP with a discharge pattern similar to the water discharge pattern.

**A.3.3.4.2 Type I Discharge Outlet.** The foam trough shown schematically in Figure A.3.3.4.2(a) consists of sections of steel sheet formed into a chute that is securely attached to the inside tank wall so that it forms a descending spiral from the top of the tank to within 4 ft (1.2 m) of the bottom. *[See Figure A.3.3.4.2(b).]*

In Figure A.3.3.4.2(b), note that one brace [ $\frac{1}{2}$  in. (13 mm) plate, 12 in. (300 mm) long] should be provided at each shell course. This brace helps maintain the shell in place during the early stages of the fire and prevents buckling before cooling water is applied.

**A.3.3.5 Eductor (Inductor).** An air foam hose nozzle with built-in eductor is the type of proportioner in which the jet in the foam maker is utilized to draft the concentrate *(see Figure A.3.3.5)*. The bottom of the concentrate container should be not more than 6 ft (1.8 m) below the level of the foam maker.

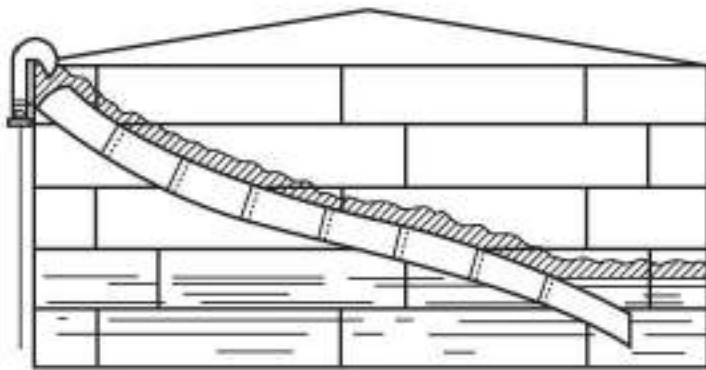


FIGURE A.3.3.4.2(a) Foam Trough.

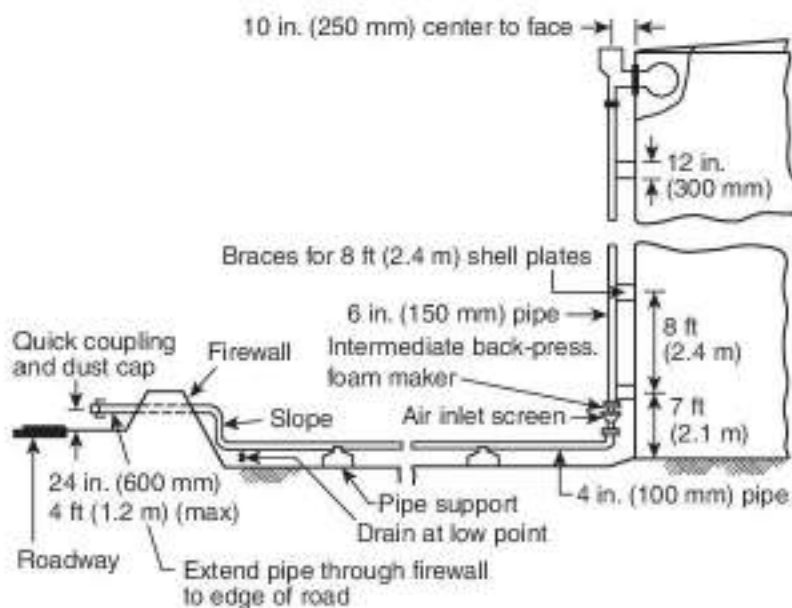


FIGURE A.3.3.4.2(b) Typical Air Foam Piping for Intermediate Back-Pressure Foam System.

The length and size of hose or pipe between the concentrate container and the foam maker should conform to the recommendations of the manufacturer. Hydrocarbon surfactant-type foam concentrates are synthetic foaming agents generally based on a hydrocarbon surface active agent. They produce foams of widely different character (expansion and drainage times), depending on the type of foam-producing devices employed. In general, such foams do not provide the stability and burn-back resistance of protein-type foams or the rapid control and extinguishment of AFFF, but they can be useful for petroleum-product spill firefighting in accordance with their listings and approvals. There are hydrocarbon-base foaming agents that have been listed as foaming agents, wetting agents, or combination foaming/wetting agents. The appropriate listings should be consulted to determine correct application rates and methods.

**A.3.3.5.1 In-Line Eductor.** This eductor is used for installation in a hoseline, usually at some distance from the foam maker or playpipe, as a means of drafting air foam concentrate from a container. (See Figure A.3.3.5 and Figure A.3.3.5.1.)

The in-line eductor must be designed for the flow rate of the particular foam maker or playpipe with which it is to be used. The device is very sensitive to downstream pressures and accordingly is designed for use with specified lengths of hose or pipe located between it and the foam maker.

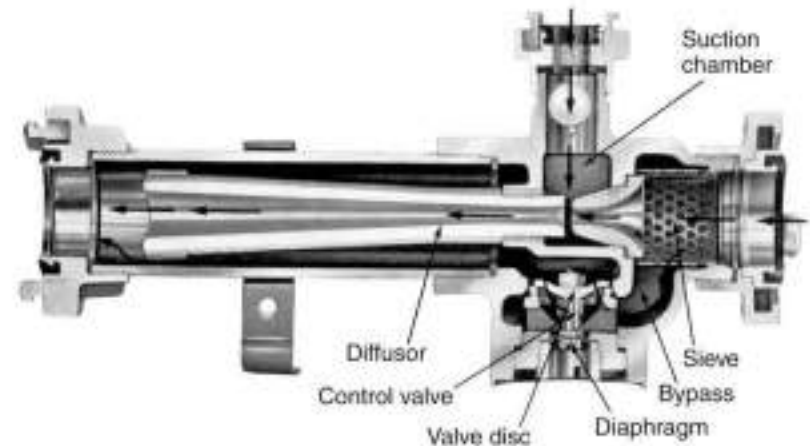
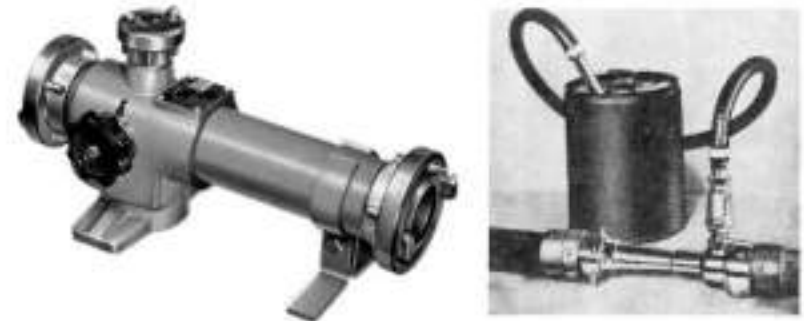


FIGURE A.3.3.5 In-Line Eductor.

The pressure drop across the eductor is approximately one-third of the inlet pressure.

The elevation of the bottom of the concentrate container should not be more than 6 ft (1.8 m) below the eductor.

**A.3.3.10 Foam.** Air foam is made by mixing air into a water solution containing a foam concentrate, by means of suitably designed equipment. It flows freely over a burning liquid surface and forms a tough, air-excluding, continuous blanket that seals volatile combustible vapors from access to air. It resists disruption from wind and draft or heat and flame attack and is capable of resealing in case of mechanical rupture. Firefighting foams retain these properties for relatively long periods of time. Foams also are defined by expansion and are arbitrarily subdivided into three ranges of expansion. These



FIGURE A.3.3.5.1 Foam Tanker.

ranges correspond broadly to certain types of usage described below. The three ranges are as follows:

- (1) Low-expansion foam — expansion up to 20
- (2) Medium-expansion foam — expansion from 20 to 200
- (3) High-expansion foam — expansion from 200 to approximately 1000

**A.3.3.12 Foam Concentrate.** For the purpose of this document, “foam concentrate” and “concentrate” are used interchangeably.

**A.3.3.12.1 Alcohol-Resistant Foam Concentrate.** There are three general types. One is based on water-soluble natural polymers, such as protein or fluoroprotein concentrates, and also contains alcohol-insoluble materials that precipitate as an insoluble barrier in the bubble structure. The second type is based on synthetic concentrates and contains a gelling agent that surrounds the foam bubbles and forms a protective raft on the surface of water-soluble fuels; these foams can also have film-forming characteristics on hydrocarbon fuels. The third type is based on water-soluble natural polymers, such as fluoroprotein, and contains a gelling agent that protects the foam from water-soluble fuels. This foam can also have film-forming and fluoroprotein characteristics on hydrocarbon fuels. Alcohol-resistant foam concentrates are generally used in concentrations of 3 percent to 10 percent solutions, depending on the nature of the hazard to be protected and the type of concentrate.

**A.3.3.12.2 Aqueous Film-Forming Foam Concentrate (AFFF).** The foam formed acts as a barrier both to exclude air or oxygen and to develop an aqueous film on the fuel surface that is capable of suppressing the evolution of fuel vapors. The foam produced with AFFF concentrate is dry chemical compatible and thus is suitable for combined use with dry chemicals.

**A.3.3.12.3 Film-Forming Fluoroprotein Foam Concentrate (FFFP).** In addition to an air-excluding foam blanket, this concentrate also can deposit a vaporization-preventing film on the surface of a liquid fuel. It is diluted with water to form 3 percent to 6 percent solutions depending on the type. This concentrate is compatible with certain dry chemicals.

**A.3.3.12.5 Fluoroprotein Foam Concentrate.** This type of foam utilizes a protein base plus stabilizing additives and inhibitors to protect against freezing, corrosion, and bacterial decomposition, and it also resists fuel pickup. The foam is usually diluted with water to form a 3 percent or 6 percent solution and is dry chemical compatible.

**A.3.3.12.6 Medium- and High-Expansion Foam Concentrate.** This equipment can be air-aspirating or blower-fan type.

**A.3.3.12.7 Protein Foam Concentrate.** These concentrates are diluted with water to form 3 percent to 6 percent solutions depending on the type. They are compatible with certain dry chemicals.

**A.3.3.12.8 Synthetic Fluorine-Free Foam (SFFF).** Contamination of per- and polyfluoroalkyl substances (PFAS) from equipment previously used with fluorinated foam concentrates or from environmental sources can potentially be found in synthetic fluorine-free foam concentrates that were not specifically manufactured using these substances.

**A.3.3.12.9.1 Other Synthetic Foam Concentrate.** In general, its use is limited to portable nozzle foam application for spill fires within the scope of their listings. The applicable listings

should be consulted to determine proper application rates and methods.

**A.3.3.14.2 Foam Generators — Blower Type.** The blower can be powered by electric motors, internal combustion engines, air, gas, or hydraulic motors or water motors. The water motors are usually powered by foam solution.

**A.3.3.16 Foam Solution.** For the purpose of this document, “foam solution” and “solution” are used interchangeably.

**A.3.3.17.1 Compressed Air Foam Systems (CAFS).** Discharge of CAFS begins with automatic actuation of a detection system, or with manual actuation that opens valves permitting compressed air foam generated in the mixing chamber to flow through a piping system and to discharge over the area served by the discharge devices or hoses. Compressed air foam systems are permitted to protect flammable and combustible liquids.

Compressed air foam systems are not permitted to be used on the following fire hazards:

- (1) Chemicals, such as cellulose nitrate, that release sufficient oxygen or other oxidizing agents to sustain combustion
- (2) Energized, unenclosed electrical equipment
- (3) Water-reactive metals such as sodium, potassium, and NaK (sodium-potassium alloys)
- (4) Hazardous water-reactive materials such as triethylaluminum and phosphorous pentoxide
- (5) Liquefied flammable gas

**A.3.3.17.2.1 Foam-Water Sprinkler System.** The piping network is equipped with discharge devices, consisting of sprinklers or nozzles, for discharging the extinguishing agent over the area to be protected. The piping is connected to the water supply through a control valve that is commonly actuated by operation of automatic detection equipment installed in the same areas as open discharge devices. When this valve opens, water flows into the piping system, foam concentrate is injected into the water, and the resulting foam solution discharging through the discharge devices generates and distributes foam. Upon exhaustion of the foam concentrate supply, water discharge follows and continues until manually shut off. Existing deluge sprinkler systems that have been converted to the use of aqueous film-forming foam or film-forming fluoroprotein foam are considered foam-water sprinkler systems.

These systems can be preprimed with foam solution. This solution would remain in the piping until the system is called upon to operate.

Preprimed systems could require draining, flushing, and repriming on a periodic basis (*see Section 10.3*). This procedure will require an investment in both time and material and should be programmed into the total system operating cost.

**A.3.3.17.2.1.1 Foam-Water Deluge System.** Foam-water sprinklers are open-type sprinklers designed to do the following:

- (1) Receive foam solution (water plus liquid concentrate)
- (2) Direct the solution through an integral foam maker, the nozzle action of which breaks the solution into spray and discharges it into a mixing tube, where it combines with air drawn in through openings in the housing
- (3) Provide mixing chamber capacity for development of the air foam
- (4) Direct the formed foam discharging from the open end of the mixing tube against a deflector, shaped to distribute the foam in a pattern essentially comparable to the

water distribution pattern of present-day standard sprinklers (nomenclature from NFPA 13) and to do so with essentially no impingement of the foam on the ceiling

- (5) Develop a water distribution pattern directly comparable to that of standard sprinklers, in the case of discharge of water only (i.e., in the absence of foam)

The normal direction of discharge from foam-water sprinklers is downward. To provide a choice in installation design, foam-water sprinklers are produced for installation in the upright position and in the pendent position with the pattern of discharge in either case in the downward direction. Sprinkler deflectors are formed to produce the required discharge pattern, which could mean differing shapes of deflectors for each of the two positions of installation. The variation in the shape of deflectors is illustrated in Figure A.3.3.17.2.1.1.

When the valve in a foam-water deluge system opens, water flows into the piping system and discharges from all discharge devices attached thereto.

**A.3.3.17.2.1.2 Foam-Water Dry Pipe System.** After the valve is opened, the water then flows into the piping system and out the opened sprinklers.

Dry pipe systems are inherently slower in operation and have a tendency to develop internal scale. Since the foam solution would be proportioned into the system upon operation, the first discharge would be an effective foam. However, due to the slower operation, this should be considered the least desirable type of sprinkler system for closed-head foam-water sprinkler application.

**A.3.3.17.2.1.3 Foam-Water Preaction System.** Actuation of the detection system opens a valve that permits water to flow into the sprinkler piping system and to be discharged from any sprinklers that have activated.



FIGURE A.3.3.17.2.1.1 Variations in Deflector Shape.

These systems combine the features of both wet pipe and dry pipe systems. The piping is empty and might or might not contain air under low pressure for supervision of the piping. There is a separate detection system that operates the water control valve to release foam solution into the piping. (The actuating means of the valve is described in NFPA 13.) This detection system should be more sensitive than the sprinkler elements.

With this arrangement, foam solution is usually released into the piping before the sprinklers operate so that, when they do, there is an immediate discharge, as with a wet pipe system. To ensure this discharge, supervision of the actuation system is recommended.

Foam solution would be proportioned into the system upon operation, so there is no need for prepriming. Overall response time generally approaches that of a wet pipe system. Actual time of foam discharge would depend on the type of separate detection system used and the type of fire. With a rapidly developing fire, the sprinklers might begin to operate very close to the initial operation of the separate detection system, and the piping might not have time to fill with foam solution to achieve immediate discharge. With a slowly developing fire, there would be sufficient time to fill the piping, and there would be a discharge of fresh foam upon sprinkler operation.

These systems are more complex than dry pipe and wet pipe systems, and this factor should be considered.

**A.3.3.17.2.1.4 Foam-Water Spray System.** Foam-water spray nozzles combine a foam maker with a body and a distributing deflector. They generate foam in the same manner described for foam-water sprinklers, where supplied with foam solution under pressure, and distribute the resulting foam, or water in the absence of foam solution, in a special pattern peculiar to the particular head.

Foam-water spray nozzles are available in a number of patterns with variations in discharge capacity. (See Figure A.3.3.17.2.1.4.)

**A.3.3.17.2.1.5 Preprimed System.** These systems have the piping normally filled with foam solution so that there is an immediate discharge of solution when the sprinkler operates. They are the fastest, simplest, and most reliable of all types of



FIGURE A.3.3.17.2.1.4 Foam-Water Spray Nozzle.

sprinkler systems. Foam concentrates in solution will form sediment or can deteriorate where stored in system piping. Contact the manufacturer for guidance.

**A.3.3.17.3 Mobile System.** For mobile systems, see NFPA 1901.

**A.3.3.17.5 Semifixed System.** The fixed piping installation might or might not include a foam maker. Necessary foam-producing materials are transported to the scene after the fire starts and are connected to the piping.

**A.3.3.18 Foam-Generating Methods.** Foam nozzle and monitor streams can also be employed for the primary protection of process units and buildings, subject to the approval of the authority having jurisdiction. The discharge characteristics of the equipment selected to produce foam nozzle and monitor streams for outdoor storage tank protection should be verified by actual tests to make certain that the streams will be effective on the hazards involved. [See Figure A.3.3.18(a) through Figure A.3.3.18(e).]

**A.3.3.18.1 Compressed Air Foam-Generating Method.** The resulting compressed air foam flows through piping or hoses to the hazard being protected.

**A.3.3.20 Handline.** The nozzle reaction usually limits the solution flow to about 300 gpm (1150 L/min).

**A.3.3.23.1 Fixed Monitor (Cannon).** The monitor can be fed solution by permanent piping or hose.

**A.3.3.24.1 Foam Nozzle or Fixed Foam Maker.** They are constructed so that one or several streams of foam solution issue into a space with free access to air. Part of the energy of the liquid is used to aspirate air into the stream, and turbulence downstream of this point creates a stable foam capable of being directed to the hazard being protected. Various types of devices can be installed at the end of the nozzle to cause the foam to issue in a wide pattern or a compacted stream.

**A.3.3.24.2 Self-Educting Nozzle.** The foam concentrate is mixed with the water at the desired proportioning injection rate.

**A.3.3.25 Pressure Foam Maker (High Back Pressure or Forcing Type).** Sufficient velocity energy is conserved in this device so that the resulting foam can be conducted through piping or hose to the hazard being protected.

**A.3.3.26.1 Balanced Pressure Pump-Type Proportioning.** By means of an auxiliary pump, foam compound is injected into the water stream passing through an inductor. The resulting foam solution is then delivered to a foam maker or playpipe. The proportioner can be inserted into the line at any point between the water source and foam maker or playpipe. (See Figure A.3.3.26.1.) To operate, the main water valve is opened and a reading of the pressure indicated on the duplex gauge is taken. When both gauge hands are set at the same point, the correct amount of foam concentrate is being injected into the water stream. This reading is done automatically by the use of a differential pressure diaphragm valve.

Metered proportioning has the following limitations:

- (1) The capacity of the proportioner can be varied from approximately 50 percent to 200 percent of its rated capacity.
- (2) The pressure drop across the proportioner ranges from 5 psi to 30 psi (34 kPa to 207 kPa), depending on the

volume of water flowing through the proportioner within the capacity limits of item (1).

- (3) A separate pump is needed to deliver concentrate to the proportioner.

**A.3.3.26.1.1 In-Line Balanced Pressure Proportioning.** A bladder tank in conjunction with a water pressure-reducing valve upstream of the proportioner can be utilized in place of the foam concentrate pump package. See Figure A.3.3.26.1.1(a) and Figure A.3.3.26.1.1(b).



FIGURE A.3.3.18(a) Handline Foam Nozzle.



FIGURE A.3.3.18(b) Adjustable Straight Stream-to-Fan Pattern Foam-Water Monitor.



FIGURE A.3.3.18(c) Adjustable Straight Stream-to-Spray Foam-Water Monitor.



FIGURE A.3.3.18(d) Wheeled Portable Foam-Water Monitor.



FIGURE A.3.3.18(e) Portable Foam-Water Monitor.

#### A.3.3.26.2 Coupled Water-Motor Driven Pump Proportioning.

The positive displacement pump draws the foam concentrate from an atmospheric storage tank and feeds it into the water flow, which passes through the water motor. The ratio between the volumes transferred per rotation of the two devices determines the proportioning ratio. Variation of the system pressure, volumetric flow rate, or viscosity of the foam concentrate will not affect the proportioning ratio because of the positive displacement character of the two devices. See Figure A.3.3.26.2.

#### A.3.3.26.3 Direct Injection Variable Pump Output Proportioning.

Direct injection foam proportioning systems utilize a foam concentrate pump to inject foam concentrate directly into the water stream. Foam proportioning system operation is not affected by water pressure or interrupted while the foam concentrate tank is refilled. Direct injection foam proportioning systems are generally automatic regulation proportioning systems. Automatic flow-sensing direct injection foam propor-

tioning systems utilize an in-line flowmeter(s) to monitor the system operating conditions. System operating data is transmitted to an electronic control, which controls the foam pump output to maintain the desired proportioning ratio. The following two different flow sensing systems are available:

- (1) An electronic control receives electronic signals corresponding to the proportioning ratio from the control panel and water flow data from the flowmeter. The electronic control then commands the foam concentrate pump module to deliver foam concentrate at the proportional rate. [See Figure A.3.3.26.3(a).]
- (2) An electronic control receives electronic signals corresponding to the foam concentrate flow from a foam concentrate flowmeter, the proportioning ratio from the control panel, and water flow data from the water flowmeter. The electronic control controls the proportioning ratio through a foam concentrate metering valve shown in Figure A.3.3.26.3(b). In a water motor foam proportioning system, a water motor drives a positive displacement foam concentrate pump. The water motor can be of either a positive displacement type or a turbine type. Water motor foam proportioning systems are automatic regulating proportioning systems. Where a positive displacement water motor drives the foam concentrate pump, the ratio of the water motor displacement to the displacement of the foam concentrate pump is the ratio of the desired foam solution. A positive displacement water motor proportioning system requires no external power. [See Figure A.3.3.26.3(c).]

A water turbine-driven foam proportioning system uses a water turbine to power a positive displacement foam concentrate pump. Flowmeters sense the foam concentrate pump output and the water flow, sending signals to an electronic control that controls the proportioning ratio by adjusting the water turbine speed. [See Figure A.3.3.26.3(d).]

#### A.3.3.28 Pump Proportioner (Around-the-Pump Proportioner).

This device consists of an eductor installed in a bypass line between the discharge and suction of a water pump. A small portion of the discharge of the pump flows through this eductor and draws the required quantity of air foam concentrate from a container, delivering the mixture to the pump suction. Variable capacity can be secured by the use of a manually controlled multiported metering valve. [See Figure A.5.2.6.1(a).]

A pump proportioner has the following limitations:

- (1) The pressure on the water suction line at the pump must be essentially zero gauge pressure or must be on the vacuum side. A small positive pressure at the pump suction can cause a reduction in the quantity of concentrate educted or cause the flow of water back through the eductor into the concentrate container. (See Figure A.3.3.28.)
- (2) The elevation of the bottom of the concentrate container should not be more than 6 ft (1.8 m) below the proportioner. (See Figure A.3.3.28.)
- (3) The bypass stream to the proportioner uses from 10 gpm to 40 gpm (38 L/min to 151 L/min) of water depending on the size of the device and on the pump discharge pressure. This factor must be recognized in determining the net delivery of the water pump.

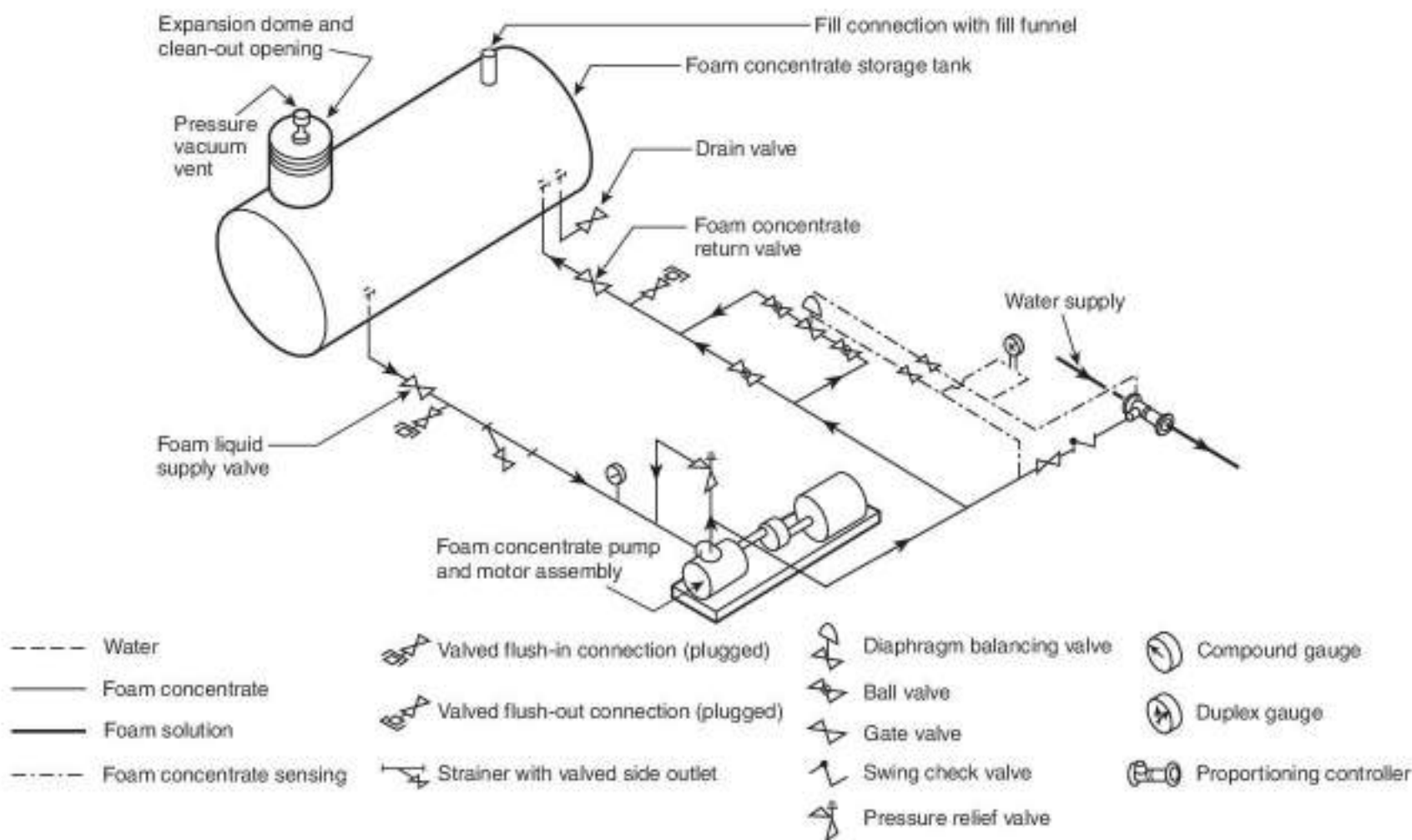


FIGURE A.3.3.26.1 Balanced Pressure Proportioning (Pump-Type) with Single Injection Point.

**A.3.3.30 Spreading Coefficient.** Spreading coefficient is given by the following equation:

$$S = T_c - T_f - T_i \quad [\text{A.3.3.30}]$$

where:

- $S$  = spreading coefficient in dynes/cm
- $T_c$  = surface tension of cyclohexane in dynes/cm
- $T_f$  = surface tension of the foam solution in dynes/cm
- $T_i$  = the interfacial tension between the foam solution and the cyclohexane in dynes/cm

**A.3.3.31.1 Cone Roof.** There are several types of roof systems that can be considered cone roofs or domes (see Figure A.3.3.31.1). The roof can be self-supporting or designed with support members such as structural chord or "radial" rafters. The roof can be supported with vertical columns as well.

A cone roof has the following characteristics:

- (1) It is used predominately for combustible liquids.
- (2) It has a fixed structural roof system that is permanent.
- (3) It will not fail or "melt" away easily.
- (4) It is vented.
- (5) It includes no other roof system, internal or otherwise.
- (6) It has no foam dam.

**A.3.3.31.2 External Floating Roof.** For the purpose of this standard, an aluminum geodesic dome is not considered a cone or dome roof. Aluminum geodesic domes are often used to cover what would otherwise be an external floating roof

system. These roof coverings cannot withstand the temperatures expected from a full surface or rim seal fire. The presence of such a covering over the top of a floating roof system will not be considered adequate to withstand a fire; therefore, the roof will still be considered an external floating roof. [See Figure A.3.3.31.2(a) and Figure A.3.3.31.2(b).]

An external floating roof has the following characteristics:

- (1) It is used predominately for both flammable and combustible liquids.
- (2) It is a floating roof system with vapor seals.
- (3) It might have a roof structure that is considered external because it is not substantial or will fail or "melt" away easily (e.g., the aluminum geodesic dome).
- (4) It is vented.
- (5) It might or might not have a foam dam.

**A.3.3.31.3 Internal Floating Roof.** There are several different types of internal floating roofs (IFR), including single- and double-deck pontoon roof systems (see Figure A.3.3.31.3). They are typically constructed of carbon steel, aluminum tubing, and plastic.

An internal floating roof has the following characteristics:

- (1) It is used predominately for flammable liquids.
- (2) It is a floating roof system with vapor seals.
- (3) It is considered internal because it is covered with a fixed structural cone or dome roof system that is permanently attached to the exterior tank shell.
- (4) It is vented or gas padded.
- (5) It might or might not have a foam dam.



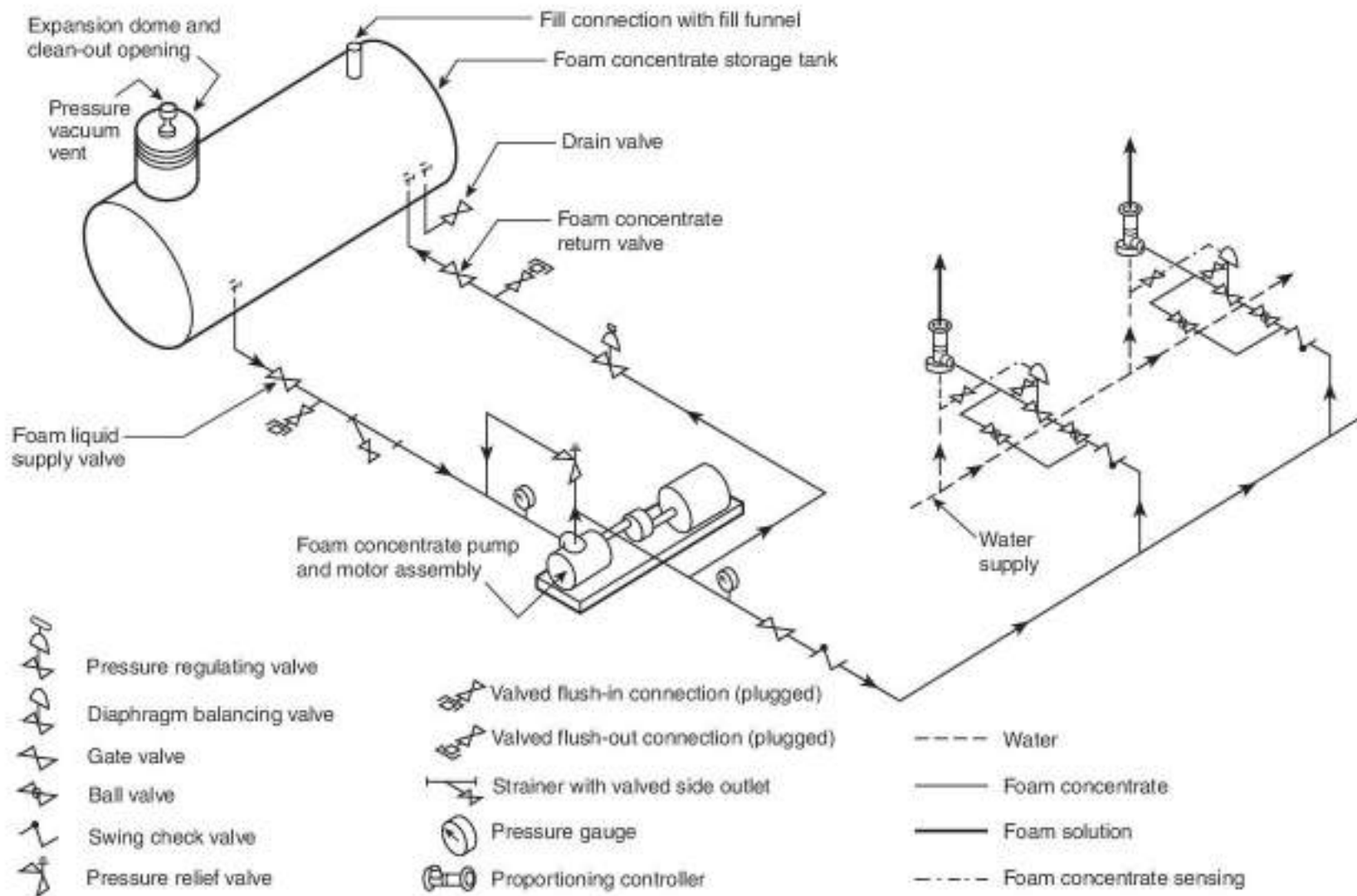


FIGURE A.3.3.26.1.1(a) In-Line Balanced Pressure (Pump-Type) Proportioning with Multiple Injection Points.

**A.3.3.32.2 Pressure Proportioning Tank.** This method employs water pressure as the source of power. With this device, the water supply pressurizes the foam concentrate storage tank. At the same time, water flowing through an adjacent venturi or orifice creates a pressure differential. The low-pressure area of the venturi is connected to the foam concentrate tank, so that the difference between the water supply pressure and this low-pressure area forces the foam concentrate through a metering orifice and into the venturi. Also, the differential across the venturi varies in proportion to the flow, so one venturi will proportion properly over a wide flow range. The pressure drop through this unit is relatively low. [See Figure A.3.3.32.2(a).]

A special test procedure is available to permit the use of a minimum amount of concentrate when the pressure proportioner system is testing.

The pressure proportioning tank has the following limitations:

- (1) Foam concentrates with specific gravities similar to water can create a problem when mixed.
- (2) The capacity of these proportioners can be varied from approximately 50 percent to 200 percent of their rated capacity.
- (3) The pressure drop across the proportioner ranges from 5 psi to 30 psi (34 kPa to 207 kPa), depending on the volume of water flowing within the capacity limits of item (2).

- (4) When the concentrate is exhausted, the system must be turned off, and the tank drained of water and refilled with foam concentrate.
- (5) Since water enters the tank as the foam concentrate is discharged, the concentrate supply cannot be replenished during operation, as with other methods.
- (6) This system proportions at a significantly reduced percentage at low flow rates and should not be used below minimum design flow rate.

A diaphragm (bladder) pressure proportioning tank also uses water pressure as a source of power. This device incorporates all the advantages of the pressure proportioning tank with the added advantage of a collapsible diaphragm that physically separates the foam concentrate from the water supply.

Diaphragm pressure proportioning tanks operate through a similar range of water flows and according to the same principles as pressure proportioning tanks. The added design feature is a reinforced elastomeric diaphragm (bladder) that can be used with all concentrates listed for use with that particular diaphragm (bladder) material. [See Figure A.3.3.32.2(b).]

The proportioner is a modified venturi device with a foam concentrate feed line from the diaphragm tank connected to the low-pressure area of the venturi. Water under pressure passes through the controller, and part of this flow is diverted into the water feed line to the diaphragm tank. This water pressurizes the tank, forcing the diaphragm filled with foam concentrate to slowly collapse. This forces the foam concen-

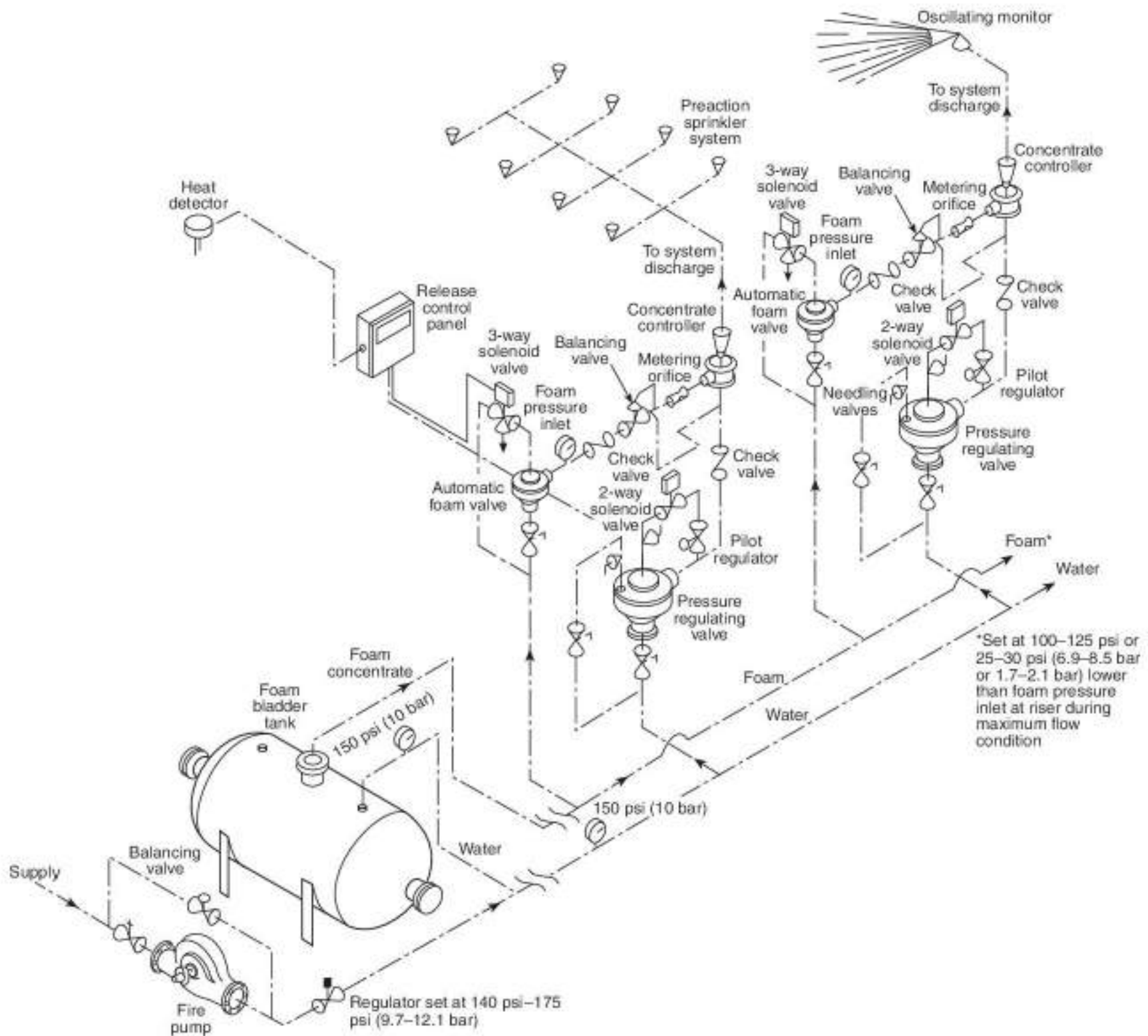


FIGURE A.3.3.26.1.1(b) In-Line Balanced Pressure (Bladder Tank Type) Proportioning with Multiple Injection Points.

trate out through the foam concentrate feed line and into the low-pressure area of the proportioner controller. The concentrate is metered by use of an orifice or metering valve and mixes in the proper proportion with the main water supply, sending the correct foam solution downstream to the foam makers.

The limitations are the same as those listed for the pressure proportioning tank, except that the system can be used for all types of concentrates.

**A.4.1** A foam system consists of a water supply, a foam concentrate supply, proportioning equipment, a piping system, foam makers, and discharge devices designed to distribute foam effectively over the hazard. Some systems include detection devices.

**A.4.1.1** FM Approvals Class 5130, UL 139, or UL 162 should be consulted for possible listing requirements.

**A.4.2.1.1** Recycled water, processed water, or gray water can be utilized for foam production. When used, a competent evaluation for the suitability of the water quality should be conducted.

**A.4.2.1.2** Additional water supplies are recommended for cooling the hot tank shell to assist the foam in sealing against the shell. Some foams are susceptible to breakdown and failure to seal as a result of heating the tank shell due to prolonged burning prior to agent discharge.

**A.4.2.1.4** Higher or lower water temperatures can reduce foam efficiency.

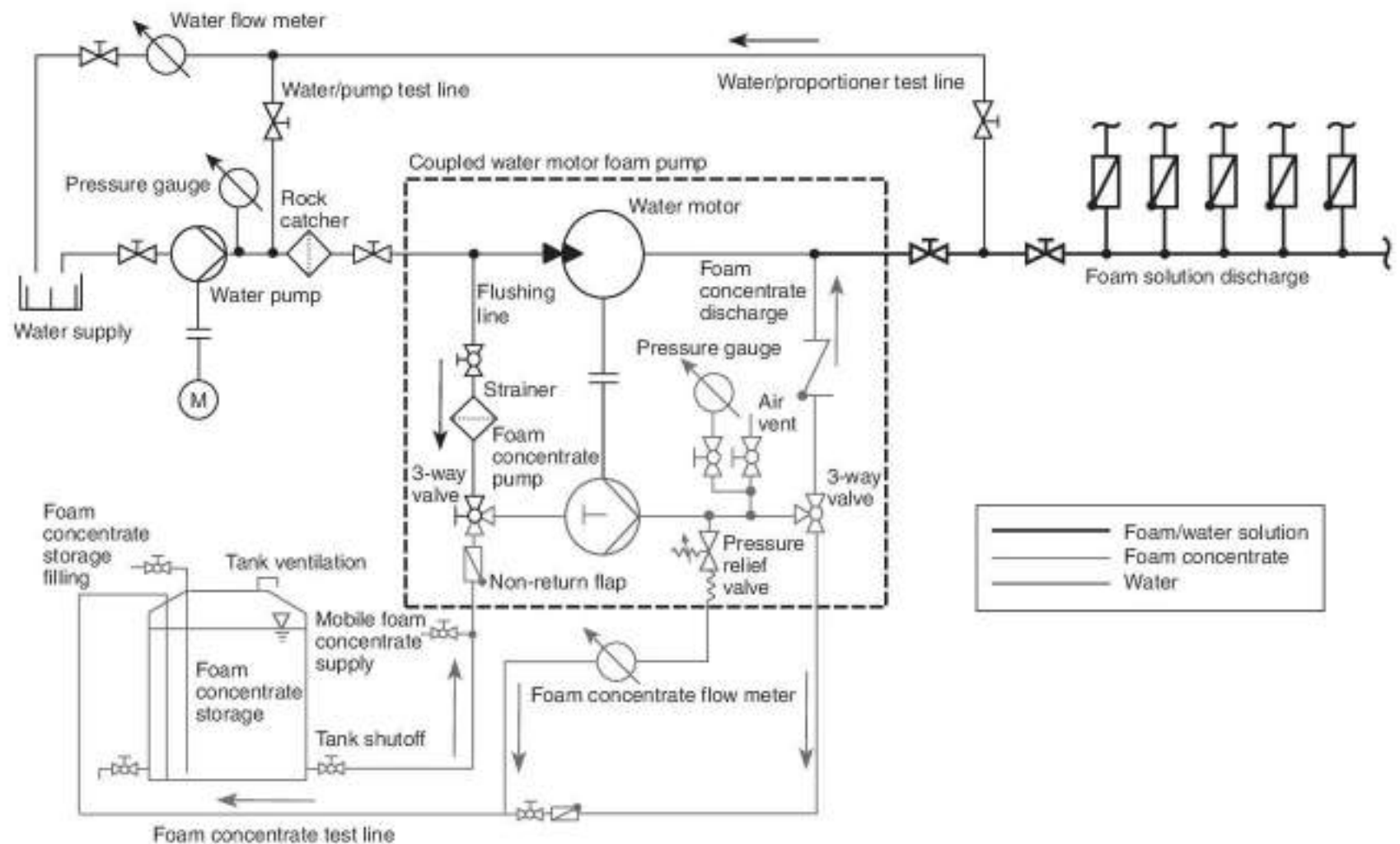


FIGURE A.3.3.26.2 Coupled Water-Motor Driven Pump Proportioning System.

**A.4.2.2.2.3** It should be ascertained whether the installation of a listed backflow prevention assembly is required.

**A.4.2.2.3.1** Local regulations might require a means for removal or containment of the largest flammable liquid spill plus the actual calculated flow from the maximum number of systems expected to operate for their calculated duration plus hose streams.

**A.4.2.3.1** The purpose of the fire department connection is to supplement the water supply but not necessarily provide the entire sprinkler system demand. Fire department connections are not intended to deliver a specific volume of water. [13:A.16.12.3.1]

**A.4.3.1.1** The foam concentrate proportioning equipment and discharge devices produce finished foam with certain qualities, including expansion ratio and 25 percent drainage time. The testing conducted by the Fire Protection Research Foundation showed that expansion ratios of 7 to 10 were critical for SFFFs' ability to extinguish fires. Consultation with the foam concentrate and/or foam equipment manufacturer might be necessary to confirm acceptable operating parameters.

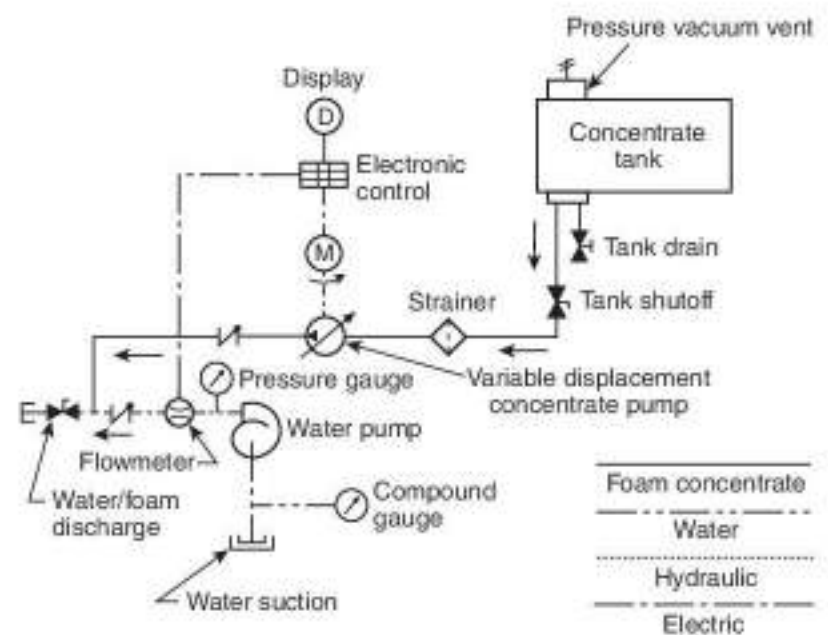


FIGURE A.3.3.26.3(a) Single-Meter Flow-Sensing Direct Injection Foam Proportioning System.

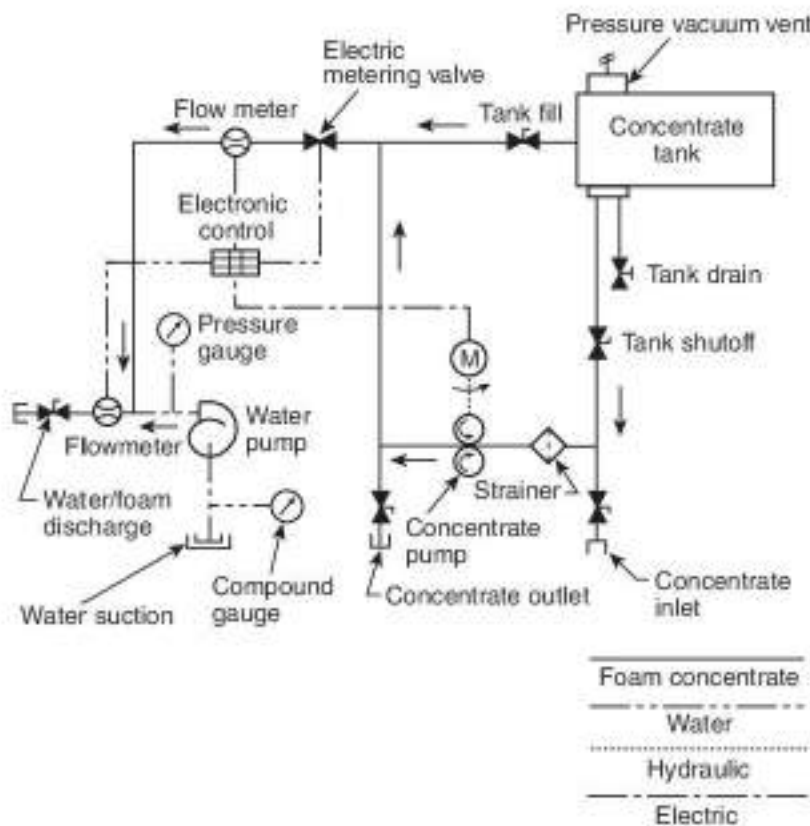


FIGURE A.3.3.26.3(b) Dual-Meter Flow-Sensing Direct Injection Foam Proportioning System.

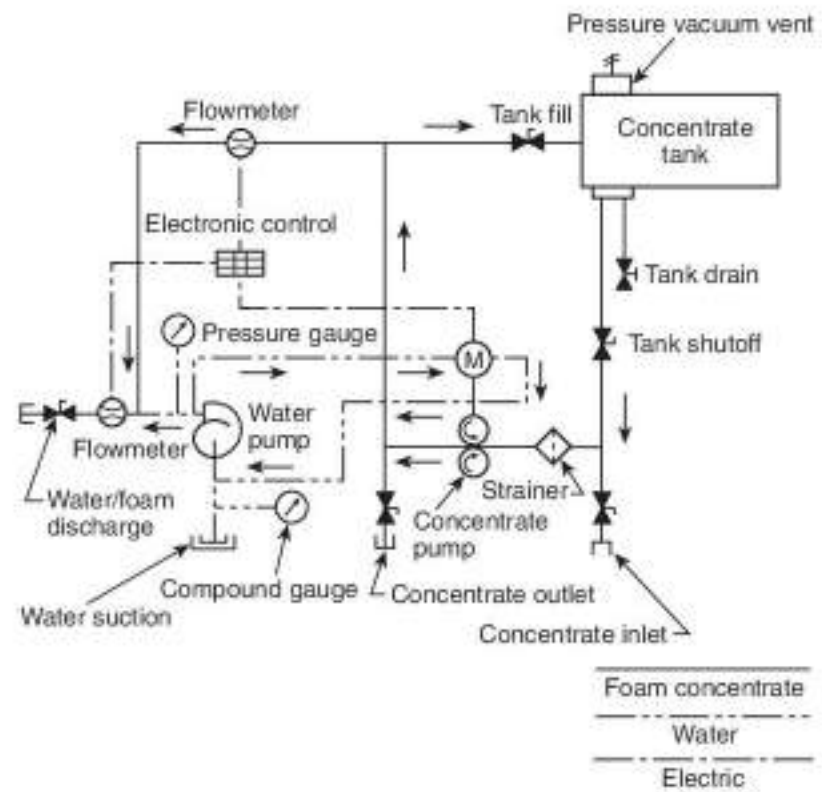


FIGURE A.3.3.26.3(d) Water Turbine-Driven Flow-Sensing Direct Injection Foam Proportioning System.

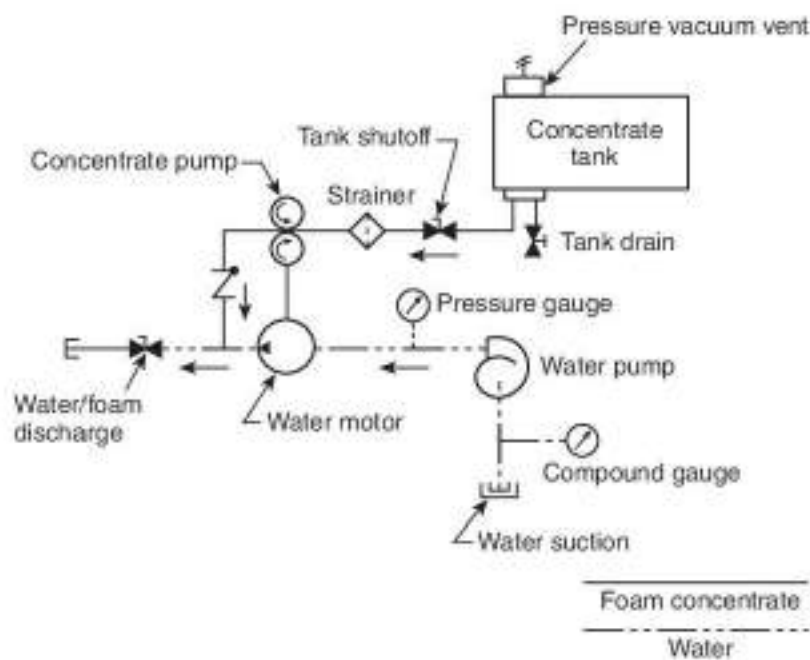


FIGURE A.3.3.26.3(c) Water Motor Foam Proportioning System.

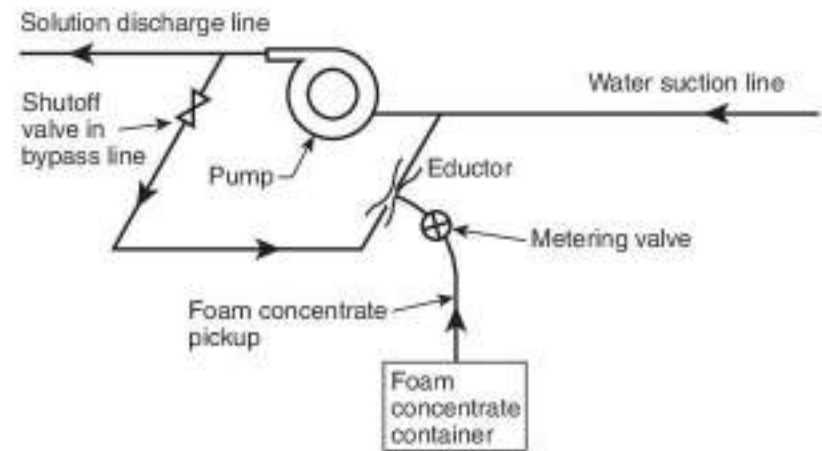
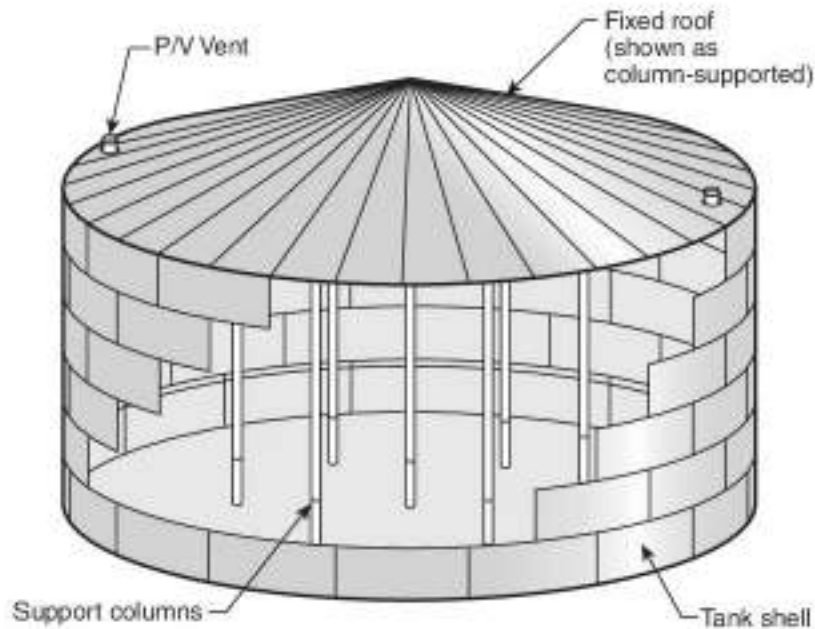


FIGURE A.3.3.28 Around-the-Pump Proportioner.

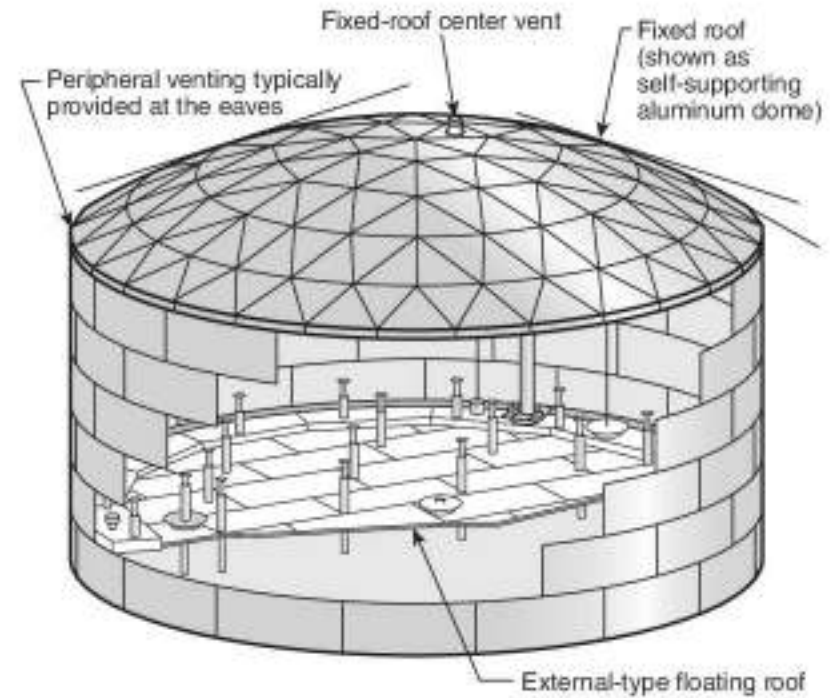
A.4.3.1.1.2 Oftentimes different brands of similar types of foam concentrates are found to be chemically compatible. However, before different types or brands of concentrates are mixed for long-term storage, evaluations should be made to determine compatibility. A number of parameters should be considered and evaluated before concentrates are mixed for storage. In addition to chemical compatibility, one should consider effects on proportioning and discharge hardware (many listings and approvals are very specific with regard to

operating pressures, flow ranges, and materials of construction of hardware components). Fire performance and foam quality resulting from the admixture of two concentrates should be no worse than the individual concentrates used in the admixture. The application method should be the same for both foams being mixed. The system design application rate (density) might have to be changed if one of the foam concentrates being admixed is listed or approved at an application rate (density) that is higher than the one used for the initial design. This generally applies to alcohol-resistant foams since their listings and approvals are application-rate sensitive.

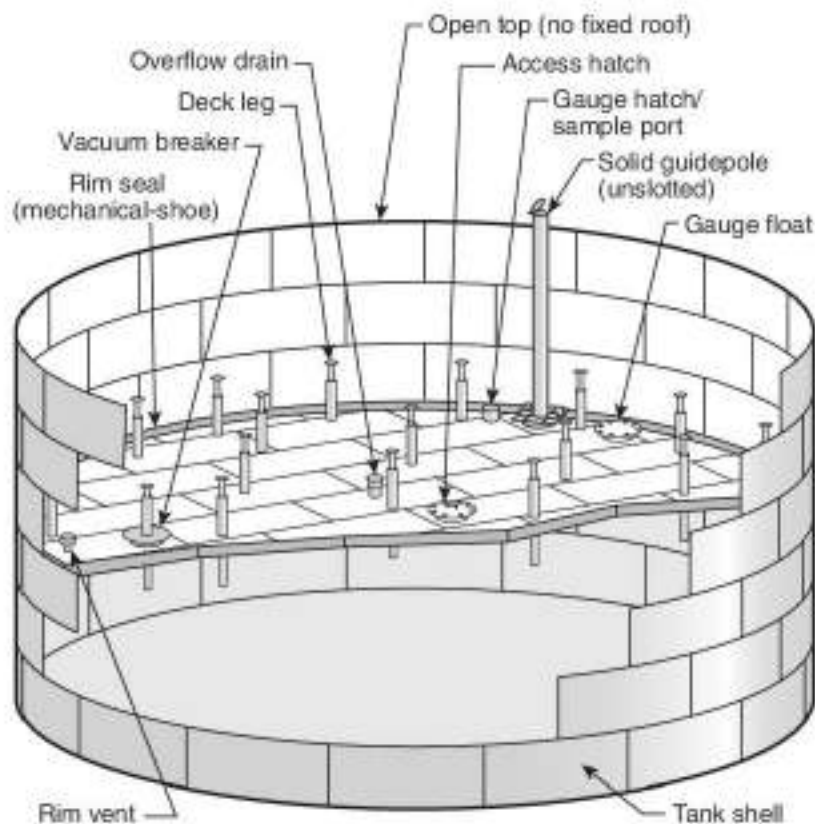
A.4.3.1.2 Some concentrates are suitable for use both on hydrocarbon fuels and on water-miscible or polar fuels and solvents.



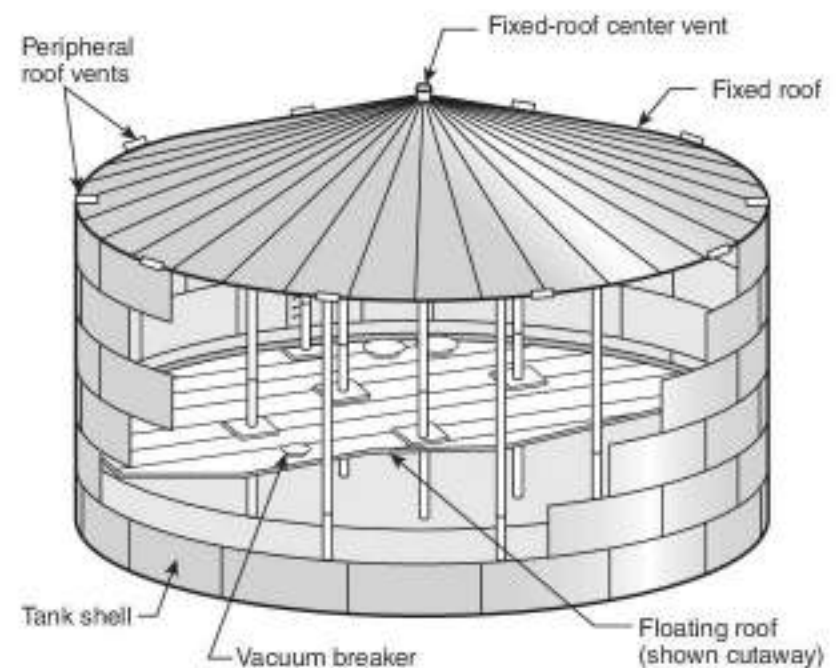
**FIGURE A.3.3.31.1 Cone/Dome Roof System.** (Source: Rob Ferry, P.E., Trinity Consultants, Inc.)



**FIGURE A.3.3.31.2(b) External Floating Roof System with Geodesic Dome (Considered External Floating).** (Source: Rob Ferry, P.E., Trinity Consultants, Inc.)



**FIGURE A.3.3.31.2(a) External Floating Roof System.** (Source: Rob Ferry, P.E., Trinity Consultants, Inc.)



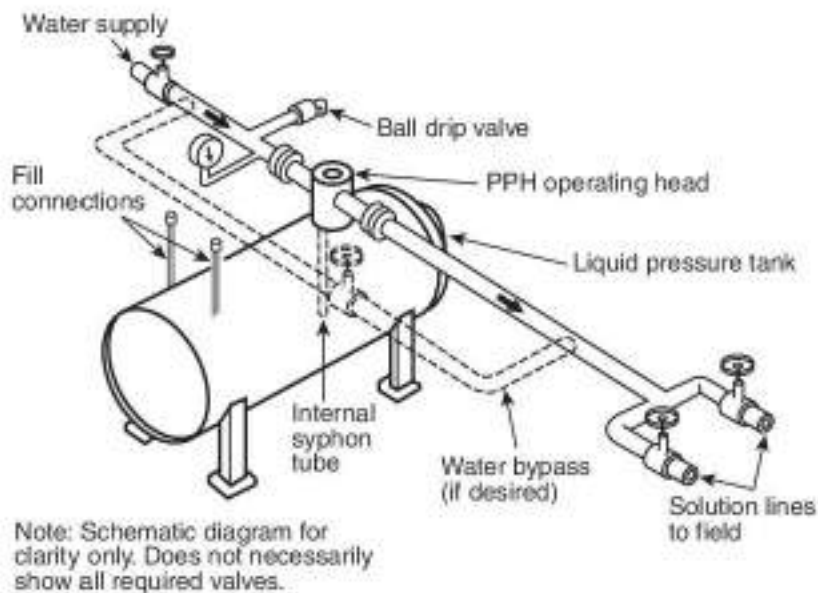
**FIGURE A.3.3.31.3 Internal Floating Roof System With Fixed Cone or Dome Roof Covering.** (Source: Rob Ferry, P.E., Trinity Consultants, Inc.)

**A.4.3.1.4(4)** The method of measurement should be identified, including the device used and parameters such as temperature, spindle number, and spindle speed in revolutions per minute (e.g., Brookfield viscometer).

**A.4.3.2.2** The level of concentrate in the storage tank should be monitored to ensure that an adequate supply is available at all times. The hazard requiring the largest foam solution flow rate does not necessarily dictate the total amount of foam concentrate required. For example, a Class II product tank requiring a flow of 300 gpm (1150 L/min) foam solution for 30 minutes would require 270 gal (1020 L) of 3 percent concentrate. A Class I product tank requiring a flow of

250 gpm (950 L/min) foam solution for 55 minutes would require 415 gal (1570 L) of 3 percent concentration.

**A.4.3.2.3.1.3** Some foam proportioning systems can have an inherent problem related to loss of foam concentrate and/or damage to bladder tanks or foam pumps if not shut down properly following system activation. There are two scenarios that can occur depending on the proportioning system arrangement. Bladder tank proportioning systems with the water feed line to the bladder tank(s) connected below the foam riser manual shutoff outside screw and yoke (OS&Y) gate valve can be vulnerable depending on the system shutdown procedure followed. When the riser shutoff valve is closed first, foam concentrate continues to flow into the depressurized riser



**FIGURE A.3.3.32.2(a) Typical Arrangement of Pressure Proportioning Tank.**

through the proportioner foam metering orifice. If this condition continues, all foam concentrate in the bladder tank will be forced into the riser and foam solution distribution piping. In-line balanced pressure or balanced pressure foam pump-type proportioning systems can also experience a similar loss of foam concentrate depending on the system installation arrangement. If the water supply (riser OS&Y) valve is located before (upstream) the foam proportioner with the foam pump still running, the same potential for foam concentrate loss exists. When the water supply (riser OS&Y) valve is closed, the foam proportioner is no longer pressurized and foam concentrate will be forced through the proportioner and metering

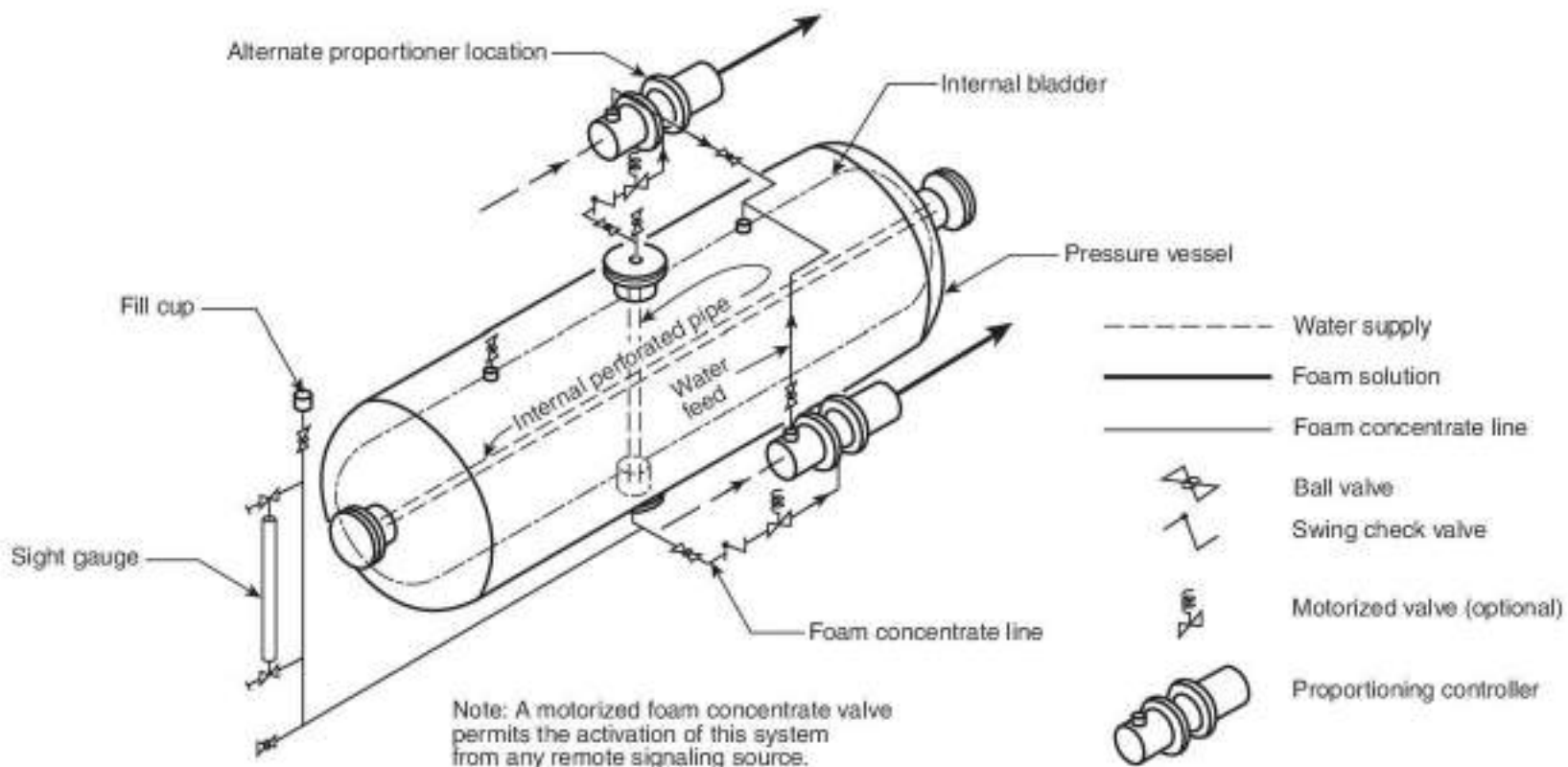
orifice into the riser. If allowed to continue, this condition will deplete the foam tank and possibly cause harm to the foam pump by running in a "dry" condition. Close the foam concentrate supply valve before shutting off the water supply valve, to prevent loss of concentrate. In the case of a pump-type system, it will allow foam to recirculate back to the foam tank until the foam pump is shut off. Alternatively, in the case of bladder tank systems, the water feed valve to the tank(s) could be closed, which would stop the foam injection process.

**A.4.3.2.3.2.4** Where sight glasses are used to gauge the foam concentrate level, they can indicate false levels if the more viscous foam concentrates are used.

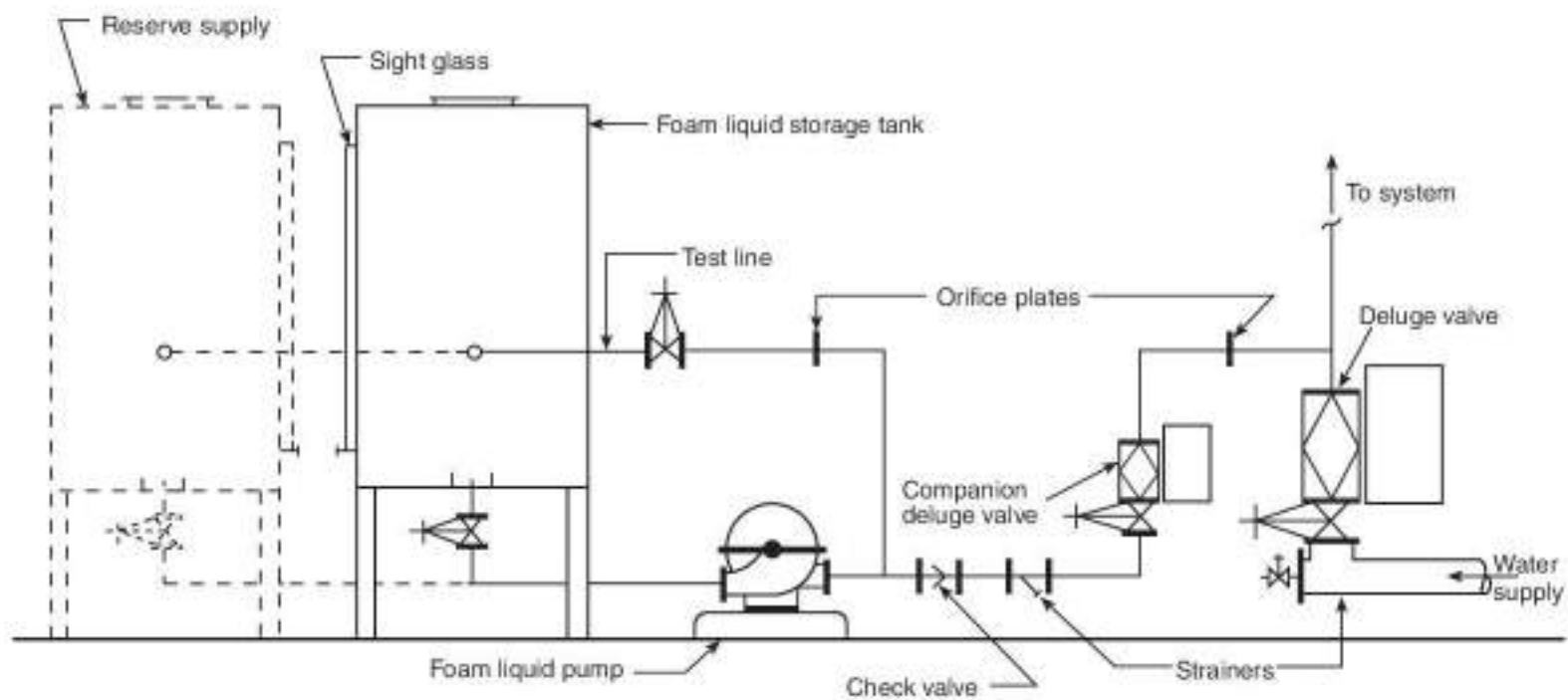
**A.4.3.2.3.3.1** Where sight glasses are used to gauge the foam concentrate level, they can indicate false levels if the more viscous foam concentrates are used.

**A.4.3.2.4.1** Since such systems might or might not be operated for long periods after installation, the choice of proper storage conditions and maintenance methods largely determines the reliability and the degree of excellence of system operation when they are put into service.

**A.4.3.2.4.2** Foam concentrates are subject to freezing and to deterioration from prolonged storage at high temperatures. The storage temperature should be monitored to ensure that listed temperature limitations are not exceeded. Concentrates can be stored in the containers in which they are transported or can be transferred into large bulk storage tanks, depending on the requirements of the system. The location of stored containers requires special consideration to protect against exterior deterioration due to rusting or other causes. Bulk storage containers also require special design consideration to minimize the liquid surface in contact with air.



**FIGURE A.3.3.32.2(b) Diaphragm (Bladder) Proportioning Tank.**



Note: Foam concentrate line strainers should only be used when acceptable to the proportioning system manufacturer.

**FIGURE A.4.5.2.2(a) Foam Liquid-Concentrate Storage Tank, Liquid-Concentrate Pump, Metering Proportions, and Interconnecting Piping.**

**A.4.4.1.1** Often, different brands of the same type of foam concentrates are found to be chemically compatible. However, before different brands of concentrates are mixed for long-term storage, evaluations should be made to determine such compatibility. A number of parameters should be considered and evaluated before concentrates are mixed for storage. In addition to the chemical compatibility, one should consider effects on proportioning and discharge hardware (many listings and approvals are very specific with regard to operating pressures, flow ranges, and materials of construction of hardware components). The application method should be the same for both foams being mixed. The system design application rate (density) might have to be changed if one of the foam concentrates being admixed is listed or approved at an application rate (density) that is higher than the one used for the initial design. This generally applies to alcohol-resistant foams since their listings and approvals are very application rate sensitive.

**A.4.4.2** Some expanded foam is not compatible with all dry chemical agents.

**A.4.5.1** Some alcohol-resistant foam proportioners require much higher flow rates to meet the minimum flow and proper proportioning percentage of the foam concentrate being used. In balanced pressure systems when the flow is less than the listed minimum, the foam percentage is less than the required where a smaller proportioner should be applied or an in-line balanced pressure proportioning system should be used when the flow rate is below the minimum listed flow rate the percentage is greater than the design percentage of the foam concentrate.

**A.4.5.2.2** Figure A.4.5.2.2(a) through Figure A.4.5.2.2(h) are schematic arrangements of equipment illustrating the principle of operation of various proportioning methods. Other arrangements or components can be used to accomplish the same purpose.

The proportioning device selected should be capable of providing a nominal concentration of foam concentrate over the range of flows and pressures for the hazard being protected. Balanced-pressure proportioning systems utilizing foam concentrate pumps will tend to proportion at a higher percentage than anticipated when operating at low flow rates. However, diaphragm or bladder tank-type systems will proportion at a significantly reduced percentage at low flow rates and, therefore, should not be used below their minimum design flow range. (See Section 9.3.)

The foam liquid-concentrate metering orifice can be calculated by using the following formula:

$$Q_c = KCd^2\sqrt{\Delta P} \quad [\text{A.4.5.2.2}]$$

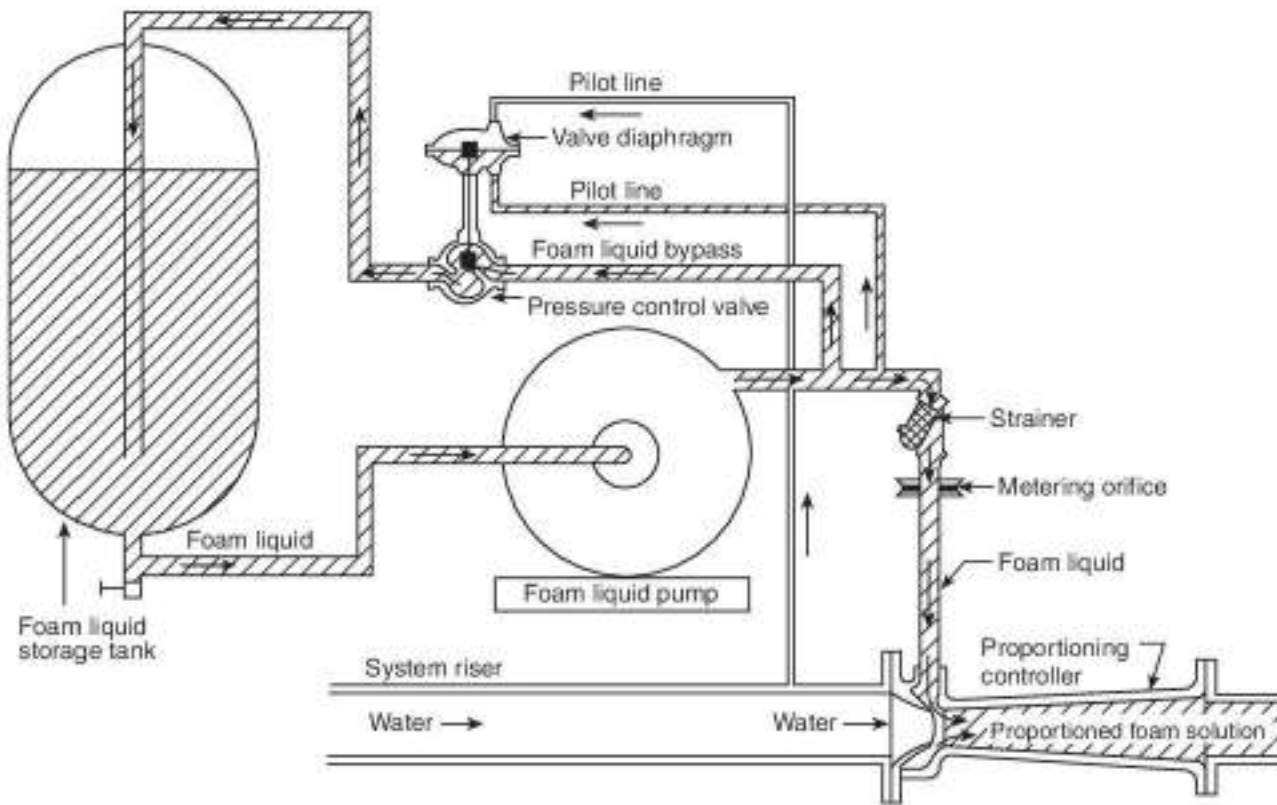
where:

- $Q_c$  = volume of foam liquid concentrate [gpm (L/min)]
- $K$  = constant of particular foam liquid concentrate (available from the manufacturer)
- $C$  = orifice constant
- $d$  = diameter of orifice [in. (mm)]
- $\Delta P$  = pressure differential across the orifice plate [psi (bar)]

The coefficient  $C$  is affected by several factors, including orifice shape, viscosity of foam liquid, velocity, and ratio of orifice diameter to pipe diameter.

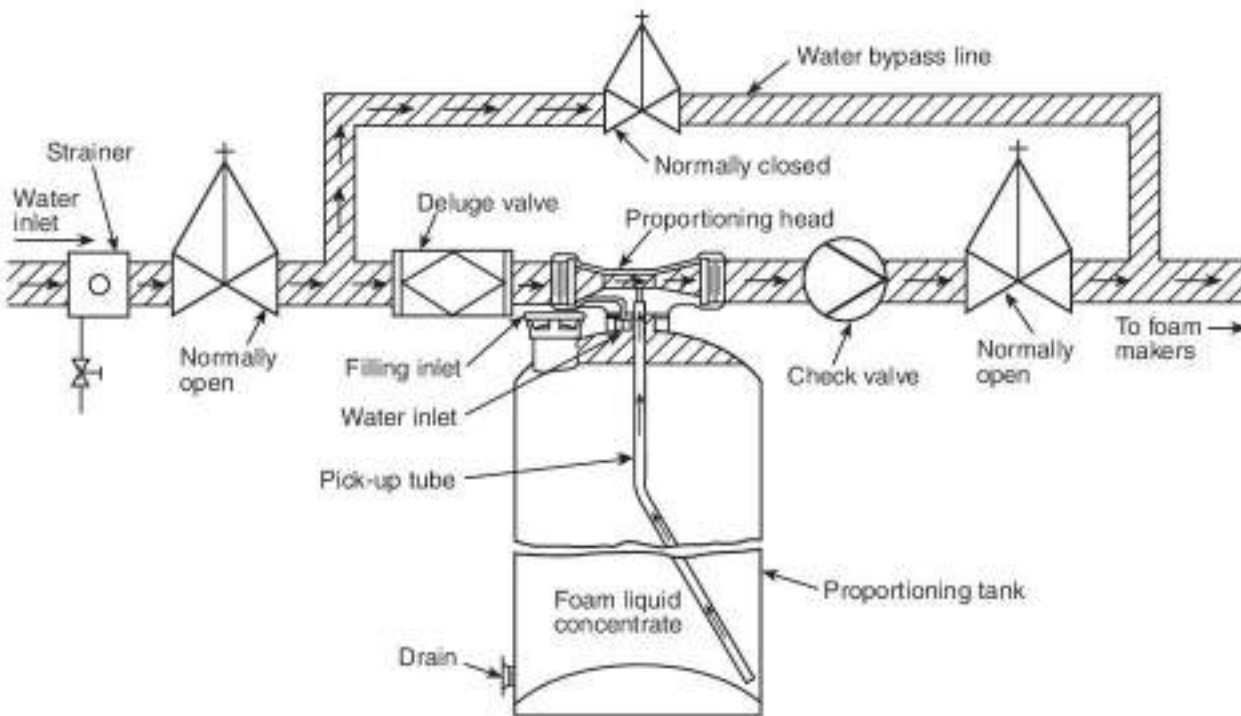
**A.4.5.2.3(3)** In-line eductors (inductors) should be used only for open-head or deluge systems.

**A.4.5.2.4** See A.4.5.2.2 for formula for calculation of size of orifices used in metering foam concentrates.



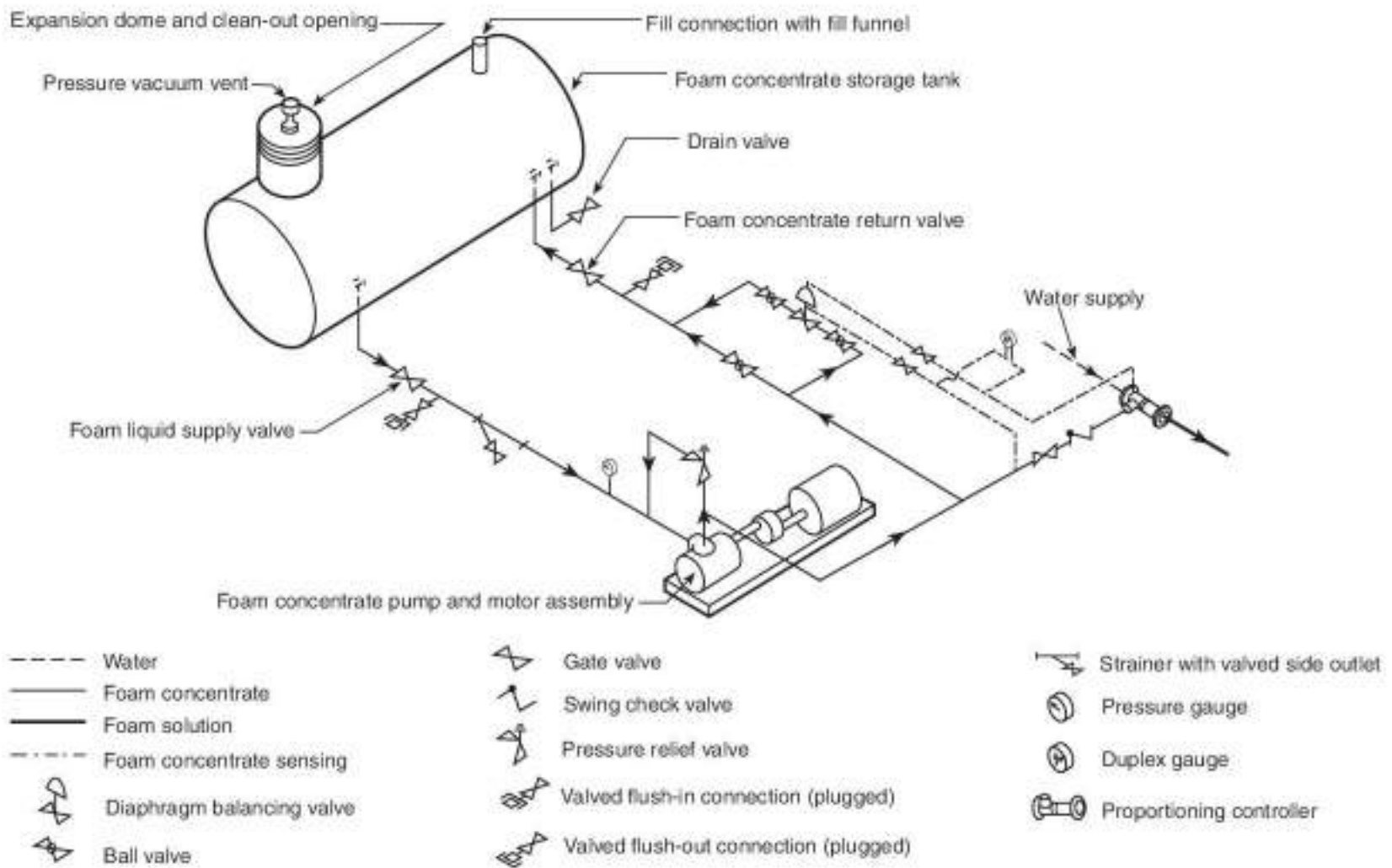
Note: Foam concentrate line strainers should only be used when acceptable to the proportioning system manufacturer.

**FIGURE A.4.5.2.2(b) Balanced-Pressure Proportioning System.**



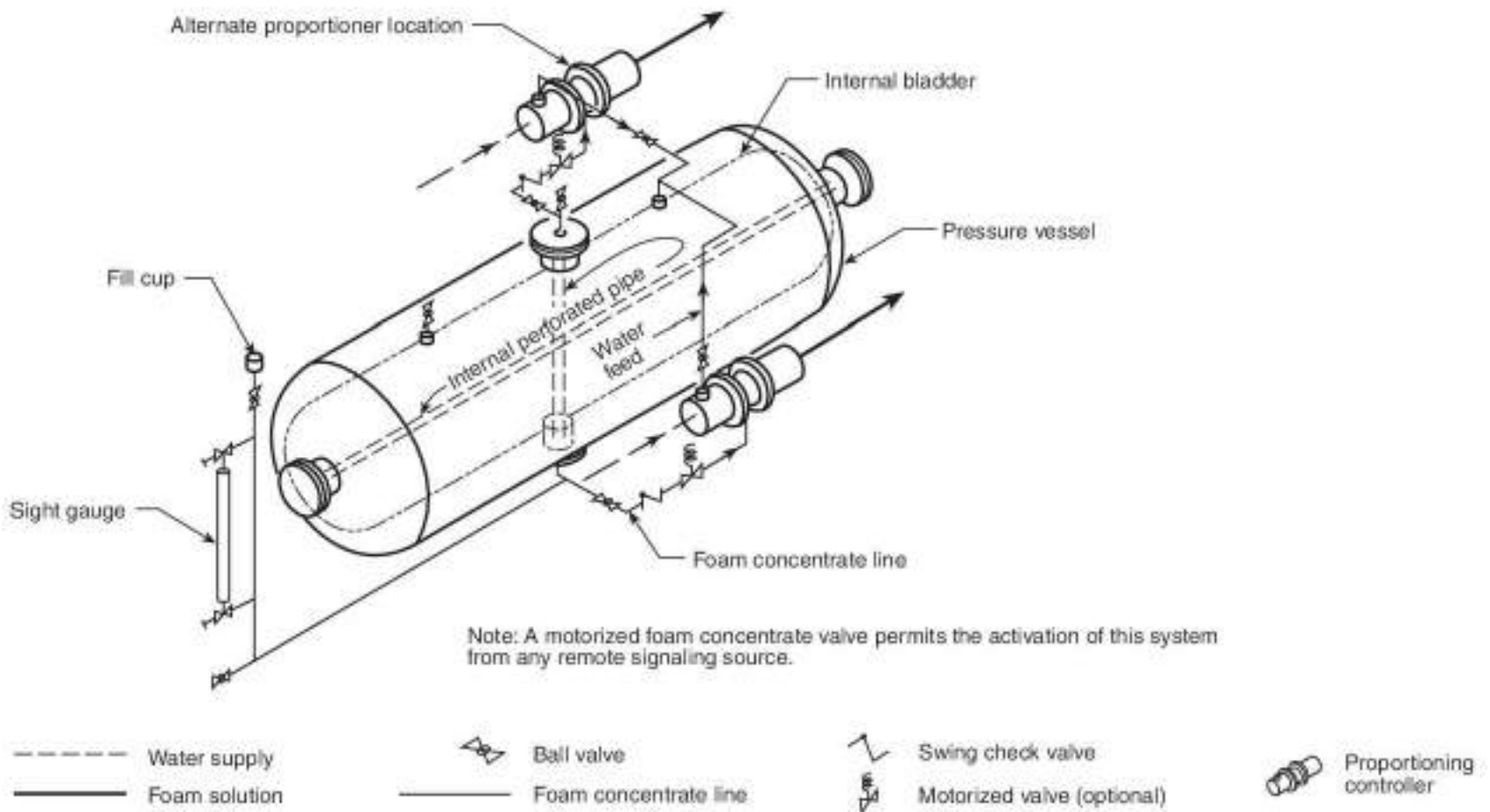
**FIGURE A.4.5.2.2(c) Pressure Proportioning Tank Method (Pressure Proportioning Tank with Diaphragm).** The arrangement of these devices can take a variety of forms. A single tank or a battery of tanks manifolded together can be used.



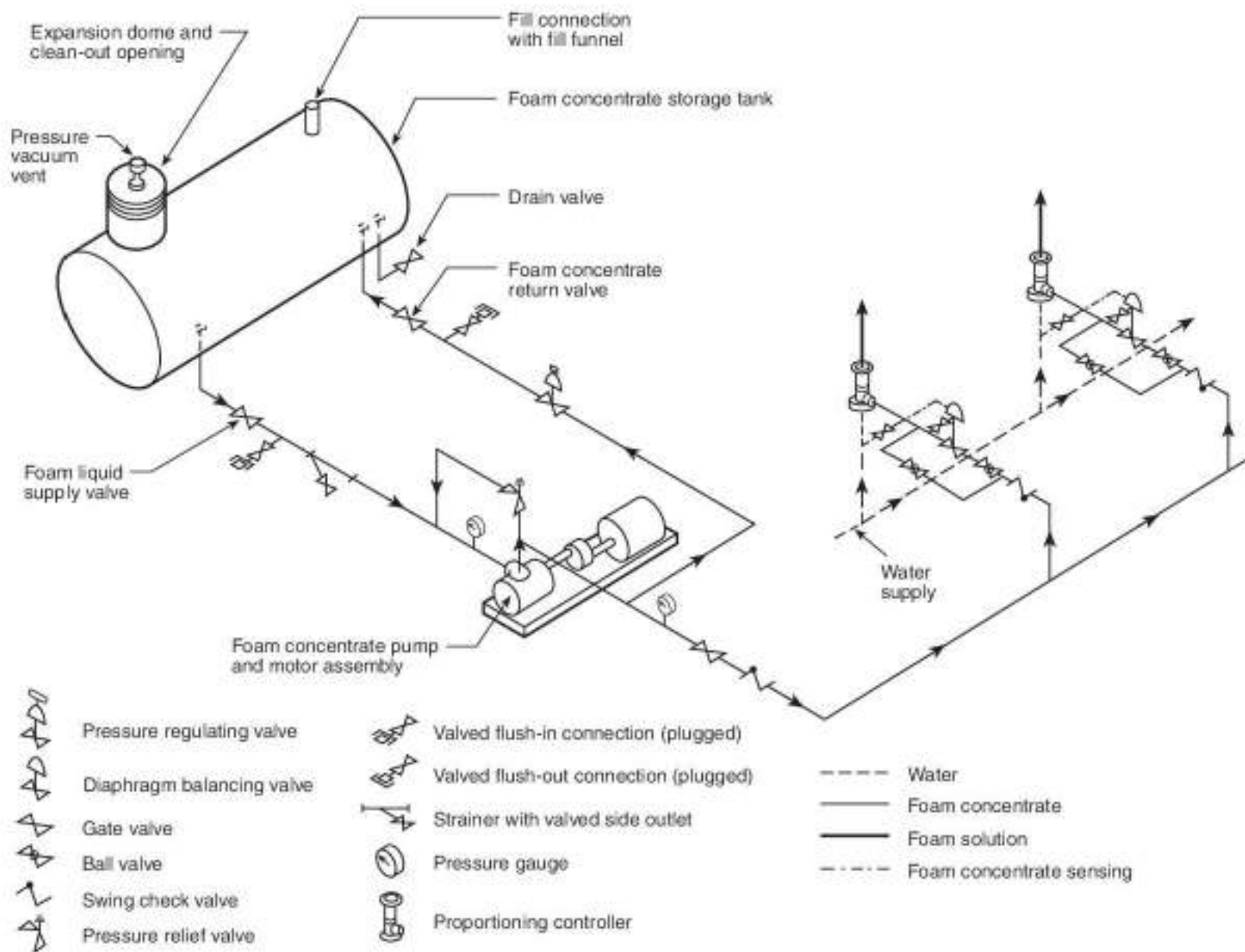


Note: Foam concentrate line strainers should only be used when acceptable to the proportioning system manufacturer.

**FIGURE A.4.5.2.2(d) Balanced-Pressure Proportioners (with Concentrate Pump).**



**FIGURE A.4.5.2.2(e) Balanced-Pressure Proportioning (Bladder System).**



Note: Foam concentrate line strainers should only be used when acceptable to the proportioning system manufacturer.

FIGURE A.4.5.2.2(f) In-Line Balanced-Pressure Proportioning System.

**A.4.6** Foam concentrate pumps are generally of the positive displacement variety. Centrifugal pumps might not be suitable for use with foam concentrates exhibiting high-viscosity characteristics. The foam equipment manufacturer should be consulted for guidance.

**A.4.6.1** Foam concentrate pumps are generally of the positive displacement variety. Centrifugal pumps might not be suitable for use with foam concentrates exhibiting high viscosity characteristics. The foam equipment manufacturer should be consulted for guidance.

**A.4.6.3.1** Any type of pump (such as a centrifugal or positive displacement pump) capable of overpressurizing the system should be provided with an adequate means of pressure relief.

**A.4.6.4.1** Flushing of the foam concentrate pump might be necessary at periodic intervals or following complete discharge of concentrate.

**A.4.6.7** Special attention should be paid to the type of seal used.

**A.4.7.1** This section addresses the pipe section that contains foam concentrate from the foam concentrate storage tank to the side inlet of the proportioner or eductor.

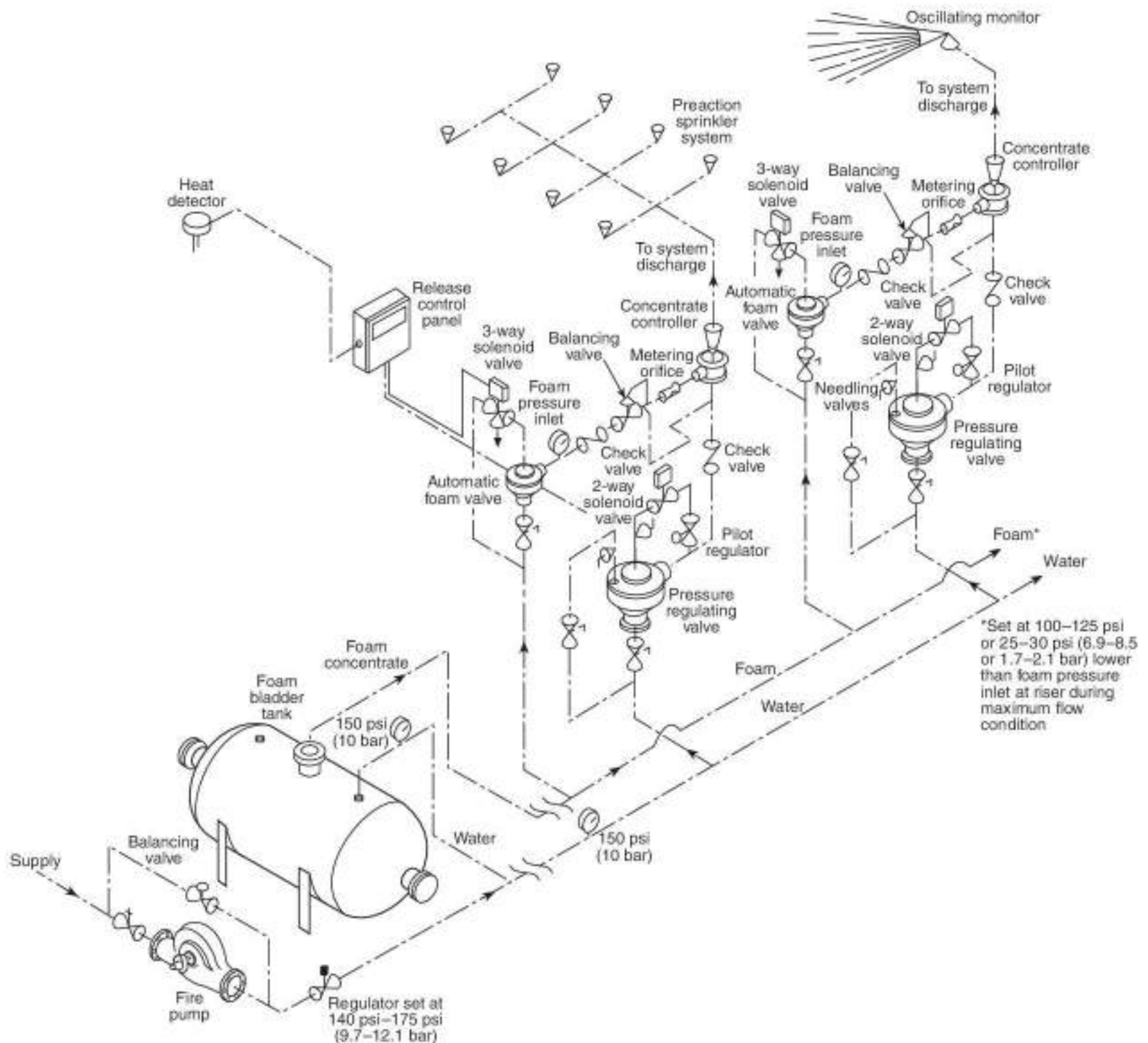
**A.4.7.1.1** Some fluoroprotein from concentrates are incompatible with stainless steel pipe. Check with the manufacturer of the foam concentrate to ensure compatibility of the foam concentrate pipe material.

**A.4.7.1.2** Carbon steel pipe has been used for concentrate pipe. Some foam concentrates, in particular alcohol-resistant foam concentrates, are corrosive to the carbon steel pipe and could deteriorate the integrity of the pipe. Carbon steel pipe is also susceptible to oxidation when air is present in the pipe.

**A.4.7.1.7** Additional pressure may be required to start flow from a static condition. The friction losses associated with large pipe networks may have a significant impact.

**A.4.7.1.9** Piping pitch is needed to drain water and is not intended to drain viscous liquids such as foam concentrate.

**A.4.7.2** This section address the pipe section(s) that contains foam solution located from the flow-through outlet of the foam concentrate proportioner or eductor to the discharge device.



**FIGURE A.4.5.2.2(g) In-Line Balanced-Pressure Proportioning System with Bladder Tank.**

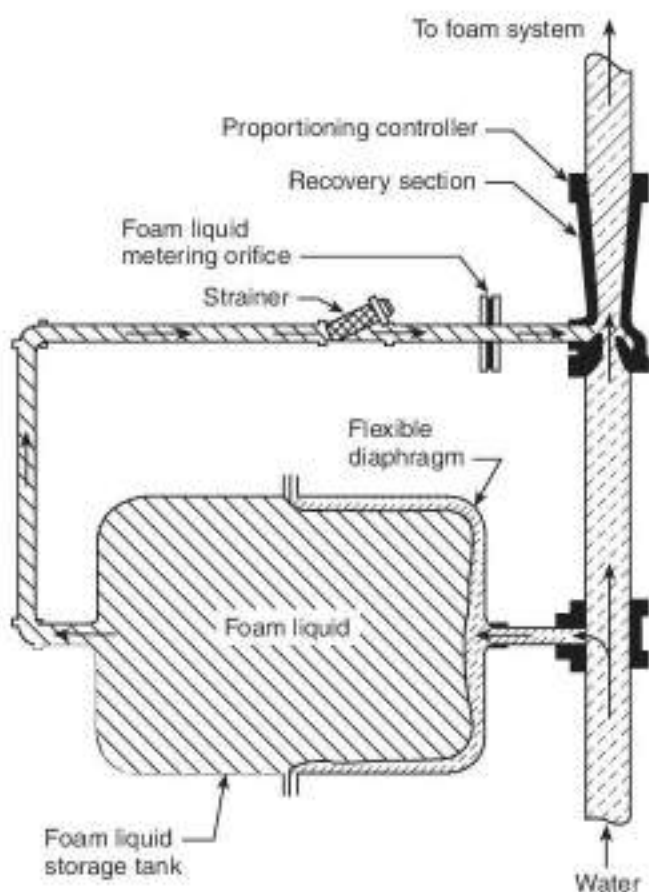
**A.4.7.2.1** Most deluge type foam water systems are subject to harsh environmental conditions, which can subject the foam solution feed line piping to internal to external corrosion. Types of systems that fall into this category include open head sprinklers, foam spray nozzles, monitors, foam chambers, fixed foam makers, fixed medium expansion foam makers, and high expansion foam systems. These systems are typically utilized for protection of fuel storage tanks, diked fuel containment areas, LNG facilities, truck and rail car loading racks, aircraft hangars, warehouses, marine docs, interior fuel storage tanks, refineries and manufacturing/processing areas

The foam solution piping on these systems is exposed to thermal changes, air movement, and other environmental conditions that can cause condensation, and the resulting

corrosion can lead to the formation of debris and pipe scale. This material can inhibit proper function of the foam system discharge devices due to blockage. To alleviate the problem of foam systems with piping that is normally open to the surrounding atmosphere, these types of systems are to be constructed using pipe fitting materials identified in 4.7.2.1 and 4.7.3.2.1. Corrosive atmospheres could require other coatings.

**A.4.7.3.1** Corrosive atmospheres could require other coatings.

**A.4.7.4.3** Welding is preferable where it can be done without introducing fire hazards.



Note: Foam concentrate line strainers should only be used when acceptable to the proportioning system manufacturer.

**FIGURE A.4.5.2.2(h) Pressure Proportioning Tank with Diaphragm.**

**A.4.7.6** A hazard area generally includes all areas within dikes and within 15 m (50 ft) of tanks without dikes. Other areas that should be considered hazard areas include the following:

- (1) Locations more than 50 ft (15 m) from tanks without dikes, if the ground slope allows exposure from accidentally released flammable and combustible liquids
- (2) Extensive manifold areas where flammable and combustible liquids might be released accidentally
- (3) Other similar areas

The presence of flammable and combustible liquids within pipelines that do not possess the potential to release flammable and combustible liquids should not be considered as creating a hazard area. Ball valves can be used for foam concentrate proportioning systems.

**A.4.7.6.5** Many valves in the foam proportioning system, if left in an incorrect position, can compromise or even disable the foam proportioning system. Examples of valves critical to proper operation of the foam proportioning system that are intended to be supervised include, but are not limited to, valves in the supply from the foam concentrate storage tank, valves in the return to the storage tank, storage tank drain valves, strainer blow-off valves, foam concentrate pump supply and discharge valves, bypass valves around diaphragm valves or pressure-regulating valves, and valves at the inlet to the proportioner.

**A.4.9.2.4** See applicable sections of *NFPA 72*.

**A.4.9.2.5** See Article 500 and other articles in Chapter 5 of *NFPA 70*.

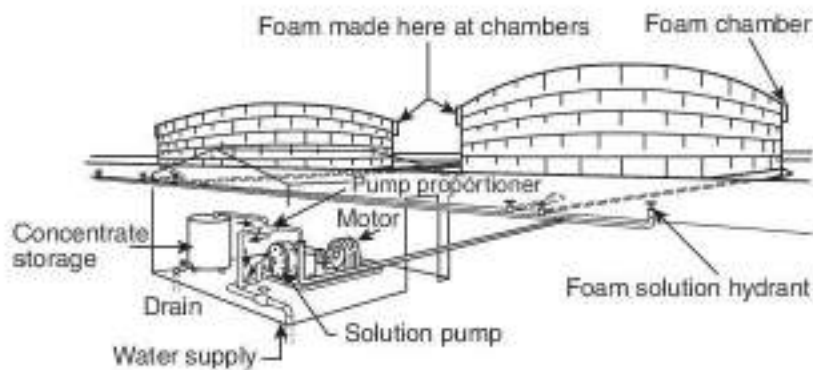
**A.5.1** There have been cases reported where the application of foam through solid streams that were plunged into the flammable liquid has been believed to be the source of ignition of the ensuing fire. The ignitions have been attributed to static discharges resulting from splashing and turbulence. Therefore, any application of foam to an unignited flammable liquid should be as gentle as possible. Correct application methods with portable equipment might include a spray pattern or banking the foam stream off a backboard so that the foam flows gently onto the liquid surface. Also, correctly designed fixed foam chambers on tanks could be expected to deliver the foam fairly gently and not cause a problem. Covered (internal) floating roof tanks can experience two distinct types of fires: a full surface area fire (as a result of the floating roof sinking) or a seal fire. There have been few fires in double-deck or pontoon-type floating roof tanks where fixed roofs and venting are designed in accordance with *NFPA 30*. Prior to selecting the method of protection, the type of fire that will serve as the basis for design should be defined.

**Outdoor Fixed-Roof (Cone) Tanks.** Within the scope of this standard, fixed-roof (cone) tanks are defined as vertical cylindrical tanks with a fixed roof designed as a conical section, and they comply with the requirements set forth in *NFPA 30*. Typically, these tanks have a weak seam at the junction of the vertical side and roof. In the event of an internal explosion, the seam usually parts and the roof blows off, leaving the shell intact to retain the tank contents. The resulting fire involves the entire exposed surface of the product.

These systems are used for the protection of outdoor process and storage tanks. They include the protection of such hazards in manufacturing plants as well as in large tank farms, oil refineries, and chemical plants. These systems usually are designed for manual operation but, in whole or in part, can be automatic in operation. Foam systems are the preferred protection for large outdoor tanks of flammable liquids, as shown in Figure A.5.1.

The following decision process is to be used by the owner or AHJ to determine the appropriate fire protection method (fixed or portable) for outdoor storage tanks:

- (1) Determine which of the following tank configurations apply (see definitions for further explanation of tank configurations):
  - (a) Cone roof tanks
  - (b) External floating roof tanks
  - (c) Aluminum geodesic dome fixed roof tank
  - (d) Internal floating roof tank
  - (e) Others that are not covered by *NFPA 11* (e.g., concrete tanks)
- (2) Determine the roof construction [The tank construction and the roof construction assist the AHJ or owner/operator in determining what type of fire protection (fixed or portable) that will be needed to protect the tank]:
  - (a) Cone roof tank (see Section 5.2 for specific fire protection details)
    - i. Steel fixed roof
  - (b) External floating roof tank (see Section 5.3 for specific fire protection details)
    - i. Steel: All roofs in accordance with Annex C of *API STD 650* designed for EFR applications are all steel construction, including buoyant compartmented sections. There are two types:



**FIGURE A.5.1** Schematic Arrangement of Air Foam Protection for Storage Tanks.

- annular pontoon floating roofs and double deck floating roofs.
- ii. Other steel or other construction: Cable supported, center annular pontoon (might not be in accordance with Annex C of API STD 650)
- (c) Internal floating roof tank (*see Section 5.4 for specific fire protection details*).
- (d) Steel double deck (in accordance with Annex C of API STD 650)
- (e) Steel annular pontoon (in accordance with Annex C of API STD 650)
- (f) Steel pans (in accordance with Annex C of API STD 650)
- (g) Aluminum, plastic, composite, or other (in accordance with Annex H of API STD 650). Annex H roofs might be steel, aluminum, composite, stainless steel, or other materials. They have much less buoyancy than Annex C roofs and are normally suitable for operation only in IFR tanks that are not exposed to the weather.
- (h) Other aluminum, plastic, composite, or other
- (3) Step 3: What is the fire hazard(s) being protected against?
  - (a) Seal area fire
  - (b) Spill on roof fire
  - (c) Full tank surface area fire
  - (d) Combination of the above
  - (e) Dike fire area
  - (f) Other type of fire
- (4) Step 4: What type of fire protection system is being selected to provide that protection? (This step should be in accordance with the section in Chapter 5 that applies to the construction as selected previously.)
  - (a) Portable handlines (dike area, seal area)
  - (b) Portable monitors (dike area, seal area, full surface)
  - (c) Fixed seal extinguishment system
  - (d) Fixed full surface extinguishment system
- (5) Step 5: Go to the section in the following list for specific fire protection requirements:
  - (a) Cone roof tank (*see Section 5.2*)
  - (b) External floating roof tank (*see Section 5.3*)
  - (c) Internal floating roof tank (*see Section 5.4*)

**A.5.2** Historical records of fixed foam systems, where the tank roof is partially damaged and open or completely blown off, would suggest that the fixed foam pourer system could have been compromised, and portable monitor nozzles might have been needed to supplement or replace the system and extinguish the fire.

**A.5.2.3** The requirements provided in this section are based on extrapolations of test experience and appropriate listings and reflect the limitations known to date. Foam can fail to seal against the tank shell as a result of prolonged free burning prior to agent discharge. If adequate water supplies are available, cooling of the tank shell is recommended. Where the entire liquid surface has been involved, fires in tanks up to 150 ft (46 m) in diameter have been extinguished with large-capacity foam monitors. Depending on the fixed-roof tank outage and fire intensity, the updraft due to chimney effect can prevent sufficient foam from reaching the burning liquid surface to form a blanket. Foam should be applied continuously and evenly. Preferably, it should be directed against the inner tank shell so that it flows gently onto the burning liquid surface without undue submergence. This can be difficult to accomplish, as adverse winds, depending on velocity and direction, reduce the effectiveness of the foam stream. Fires in fixed-roof tanks with ruptured roofs that have only limited access for foam application are not easily extinguished by monitor application from ground level. Fixed foam monitors can be installed for protection of drum storage areas or diked areas.

**A.5.2.4.1.1** Since the most common cone roof tank fire involves an overflow of the cone roof tank or an internal explosion that results in total or partial roof separation, the AHJ should develop and approve appropriate response tactics to deal with each credible scenario when mobile foam monitors or handlines are selected as the method to be used. The pre-incident contingency plan should be in accordance with API RP 2021.

Testing by the Copenhagen Airport Fire Department and the LASTFIRE Consortium has demonstrated that some SFFF can be applied to both spill and fuel in-depth fires using monitor nozzles to successfully extinguish those types of fires.

**A.5.2.4.2.1** The specified minimum delivery rate for primary protection assumes that the additional foam solution that is determined using the 1.5 factor will be enough to deliver the remaining needed specified foam to the area being protected. Testing by the FPRF would suggest that some SFFF needs to be air-aspirated. Nozzles with an air-aspiration factor of at least 8 to 10 should be used.

**A.5.2.4.2.2** Where protection is desired for hydrocarbons having a flash point above 200°F (93.3°C), a minimum discharge time of 35 minutes should be used.

**A.5.2.4.3** When some older types of alcohol-resistant foam concentrate are used, consideration should be given to solution transit time. Solution transit time (i.e., the elapsed time between injection of the foam concentrate into the water and the induction of air) might be limited, depending on the characteristics of the foam concentrate, the water temperature, and the nature of the hazard protected. The maximum solution transit time of each specific installation should be within the limits established by the manufacturer.

**A.5.2.4.3.1** In general, alcohol-resistant foams can be effectively applied through foam monitor or foam hose streams to spill fires of these liquids where the liquid depth does not exceed 1 in. (25 mm). Recent FPRF testing on SFFF would suggest that any gasoline with a minimum of 10 percent ethanol must be treated as a polar solvent for foam selection purposes.

**A.5.2.4.3.2** If application results in foam submergence, the performance of alcohol-resistant foams usually deteriorates significantly, particularly where there is a substantial depth of fuel. The degree of performance deterioration depends on the degree of water solubility of the fuel (i.e., the more soluble, the greater the deterioration). Special alcohol-resistant foams are available for polar solvents in depths greater than 1 in. (25 mm) in both AFFF and SFFF.

**A.5.2.4.4** Foam should not be used with monitors or handlines to plunge into polar solvents such as ethanol. Every effort should be made to apply the foam as gently as possible to the fuel surface. When using handlines, care should be exercised to gently apply the foam.

**A.5.2.5.1** For this application, discharge outlets are commonly called foam chambers. Most foam chambers are of a Type II discharge outlet design, since they are normally suitable for use with modern foams.

**A.5.2.5.2.1** It is recommended that, for tanks greater than 200 ft (61 m) in diameter, at least one additional discharge outlet should be added for each additional 5000 ft<sup>2</sup> (460 m<sup>2</sup>) of liquid surface or fractional part thereof. Since there has been limited experience with foam application to fires in fixed-roof tanks greater than 140 ft (43 m) in diameter, requirements for foam protection on such tanks are based on the extrapolation of data from successful extinguishments in smaller tanks. Tests have shown that foam can travel effectively across at least 100 ft (30 m) of burning liquid surface. On fixed-roof tanks of over 200 ft (61 m) diameter, subsurface injection can be used to reduce foam travel distances for tanks containing hydrocarbons only. Unless subsurface foam injection is utilized, a properly sized flanged connection should be installed on all atmospheric pressure storage tanks, regardless of present intended service, to facilitate the future installation of an approved discharge outlet if a change in service should require such installation. Figure A.5.2.5.2.1(a) and Figure A.5.2.5.2.1(b) are typical fixed foam discharge outlets or foam chambers.

**A.5.2.5.2.2** Type I discharge outlets are considered obsolete, and Type I outlets that are damaged effectively become Type II outlets. Minimum discharge times and application rates for Type I outlets currently installed are provided in Table 5.2.5.2.2 for fixed-roof tanks storing hydrocarbons and in Table 5.2.5.3.4 for flammable and combustible liquids requiring alcohol-resistant foams.

**A.5.2.5.3** The system should be designed based on fighting a fire in one tank at a time. The rate of application for which the system is designed should be the rate computed for the protected tank considering both the liquid surface area and the type of flammable liquid stored. For example, the property contains a 40 ft (12 m) diameter tank storing ethyl alcohol and 35 ft (11 m) diameter tank storing isopropyl ether. The liquid surface area of a 40 ft (12 m) diameter tank equals 1257 ft<sup>2</sup> (117 m<sup>2</sup>). Assuming the solution rate for ethyl alcohol is 0.1 gpm/ft<sup>2</sup> (4.1 mm/min), then 1257 gpm/ft<sup>2</sup> × 0.1 = 126 gpm (477 L/min). The liquid surface area of a 35 ft (11 m) diameter tank equals 962 ft<sup>2</sup> (89 m<sup>2</sup>).

Assuming the solution rate for isopropyl ether is 0.15 gpm/ft<sup>2</sup> (6.1 mm/min), then 962 ft<sup>2</sup> × 0.15 gpm/ft<sup>2</sup> = 144 gpm. For SI units: Solution rate = 89 × 6.1 = 543 L/min. In this example, the smaller tanks storing the more volatile product require the higher foam-generating capacity. In applying this requirement, due consideration should be given to the future possibility of

change to a more hazardous service requiring greater rates of application. Unfinished solvents or those of technical grade can contain quantities of impurities or diluents. The proper rate of application for these, as well as for mixed solvents, should be selected with due regard to the foam-breaking properties of the mixture.

**A.5.2.5.3.2** Systems using these foams require special engineering consideration.

**A.5.2.6.1** Experience with fuel storage tank firefighting has shown that the main problems are operational (i.e., difficulty in delivering the foam relatively gently to the fuel surface at an application rate sufficient to effect extinguishment). A properly engineered and installed subsurface foam system offers the potential advantages of less chance for foam-generation equipment disruption as a result of an initial tank explosion or the presence of fire surrounding the tank, and the ability to conduct operations a safe distance from the tank. Thus, the opportunity for establishing and maintaining an adequate foam application rate is enhanced. The following guidelines regarding fire attack are recommended. After necessary suction connections are made to the water supply and foam-maker connections are made to foam lines, foam pumping operations should be initiated simultaneously with opening of block valves permitting the start of foam flow to the tank. Solution pressure should be brought up to and maintained at design pressure.

When foam first reaches the burning liquid surface, there can be a momentary increase in intensity caused by the mechanical action of steam formation when the first foam contacts the heat of the fire. Initial flame reduction and reduc-



**FIGURE A.5.2.5.2.1(a) Foam Chamber.**



FIGURE A.5.2.5.2.1(b) Foam Chamber Deflector.

tion of heat is then usually quite rapid, and gradual reduction in flame height and intensity will occur as the foam closes in against the tank shell and over the turbulent areas over foam injection points. If sufficient water supplies are available, cooling of the tank shell at and above the liquid level will enhance extinguishment and should be used. Care should be taken that water streams are not directed into the tank where they could disrupt the established foam blanket. After the fire has been substantially extinguished by the foam, some fire can remain over the point of injection. With flash points below 100°F (38°C) (Class IB and Class IC liquids), the fire over the turbulent area will continue until it is adequately covered by foam. With gasoline or equivalent liquids, when fire remains only over the area of injection, intermittent injection should be used so that foam will retrogress over the area during the time foam injection is stopped. Depending on local circumstances, it might be possible to extinguish any residual flickers over the turbulent area with portable equipment rather than continue the relatively high rate of application to the whole tank. If the tank contains a burning liquid capable of forming a heat wave, a slop-over can occur from either topside or subsurface injection of foam, especially if the tank has been burning for 10 minutes or longer. Slop-over can be controlled by intermittent foam injection or reduction in foam-maker inlet pressure until slop-over ceases. Once slop-over has subsided, and in the case of liquids that do not form a heat wave, the pump rate should be continuous. Figure A.5.2.6.1(a) and Figure

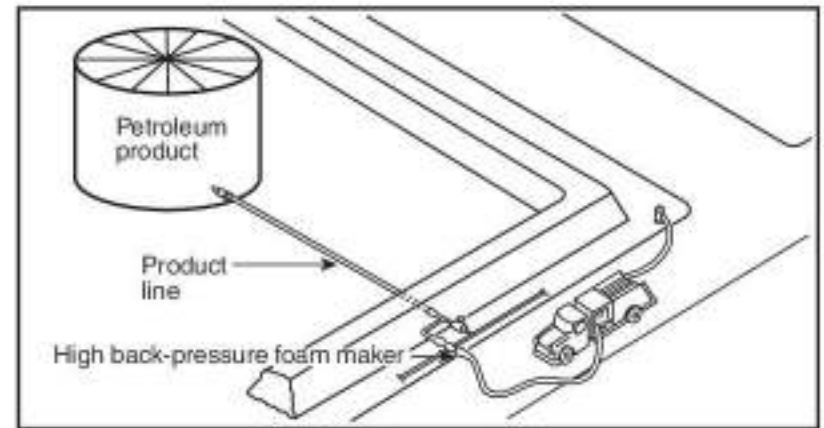


FIGURE A.5.2.6.1(a) Semifixed Subsurface Foam Installation.

A.5.2.6.1(b) illustrate typical arrangements of semifixed subsurface systems.

**A.5.2.6.1.2** The expansion ratios for subsurface injection are typically between 2:1 and 4:1. Limited testing with SFFFs applied with subsurface form injection systems suggests that, for some fuels, some SFFFs can be applied using subsurface foam injection systems. However, the user should check with the specific foam manufacturer to confirm that it has been tested for that use.

**A.5.2.6.2** Figure A.5.2.6.2(a) through Figure A.5.2.6.2(c) should be used to determine foam velocity. Expanded foam flow rate, adjusted to the supply curve, should be used for this calculation; that is, multiply the supply calculation flow rate by the maximum expansion ratio of 4:1. Expanded foam velocity also can be calculated by using the following formulas:

$$\text{English velocity (ft/sec)} = \frac{\text{Expanded foam (gpm)}}{KA} \quad [\text{A.5.2.6.2a}]$$

where:

gpm = gallons per minute

$K$  = constant 449

$A$  = area of ID of the injection pipe (ft<sup>2</sup>)

or

$$V = \frac{\text{gpm foam}}{d^2} \times 0.4085 \quad [\text{A.5.2.6.2b}]$$

where:

$d$  = pipe ID (in.)

[A.5.2.6.2c]

$$\text{Metric velocity (m/sec)} = \frac{\text{L./min foam}}{d^2} \times 21.22$$

where:

$d$  = pipe ID (mm)

Figure A.5.2.6.2(d) illustrates optional arrangements for multiple subsurface discharge outlets.

**A.5.2.6.2.4** Fire tests have proven that most types of firefighting foam applied by monitors, fixed foam appliances, and compressed air foam appliances can and will travel over a burning fuel surface greater than 100 ft (30 m). Test results show that travel of 130 ft (40 m) to as much as 150 ft (46 m) is possible. See *LASTFIRE Ongoing Testing of New Generation Foams DFW Large Scale Extended Flow Test Report* for supporting test data.

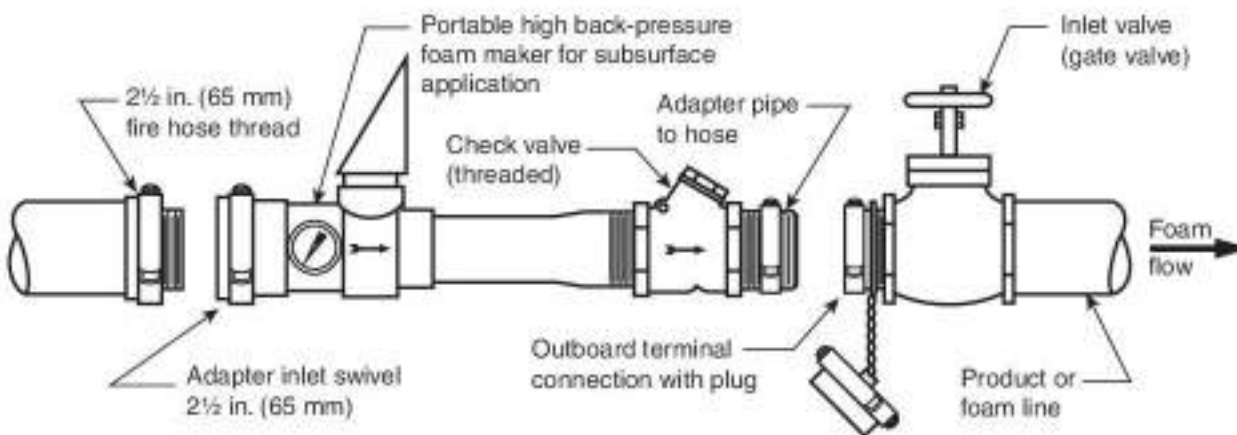
**A.5.2.6.3** Figure A.5.2.6.3 illustrates a typical foam inlet tank connection.

**A.5.2.6.3.1** Liquid hydrocarbons that contain foam-destructive products might require higher application rates. Some foams might fail to extinguish fires in gasolines containing oxygenates where subsurface discharge is used at the usually required rate. Optimum fluoroprotein foam, AFFF, and FFFP characteristics for subsurface injection purposes should have expansion ratios between 2 and 4. [See Figure A.5.2.6.3.1(a) and Figure A.5.2.6.3.1(b).]

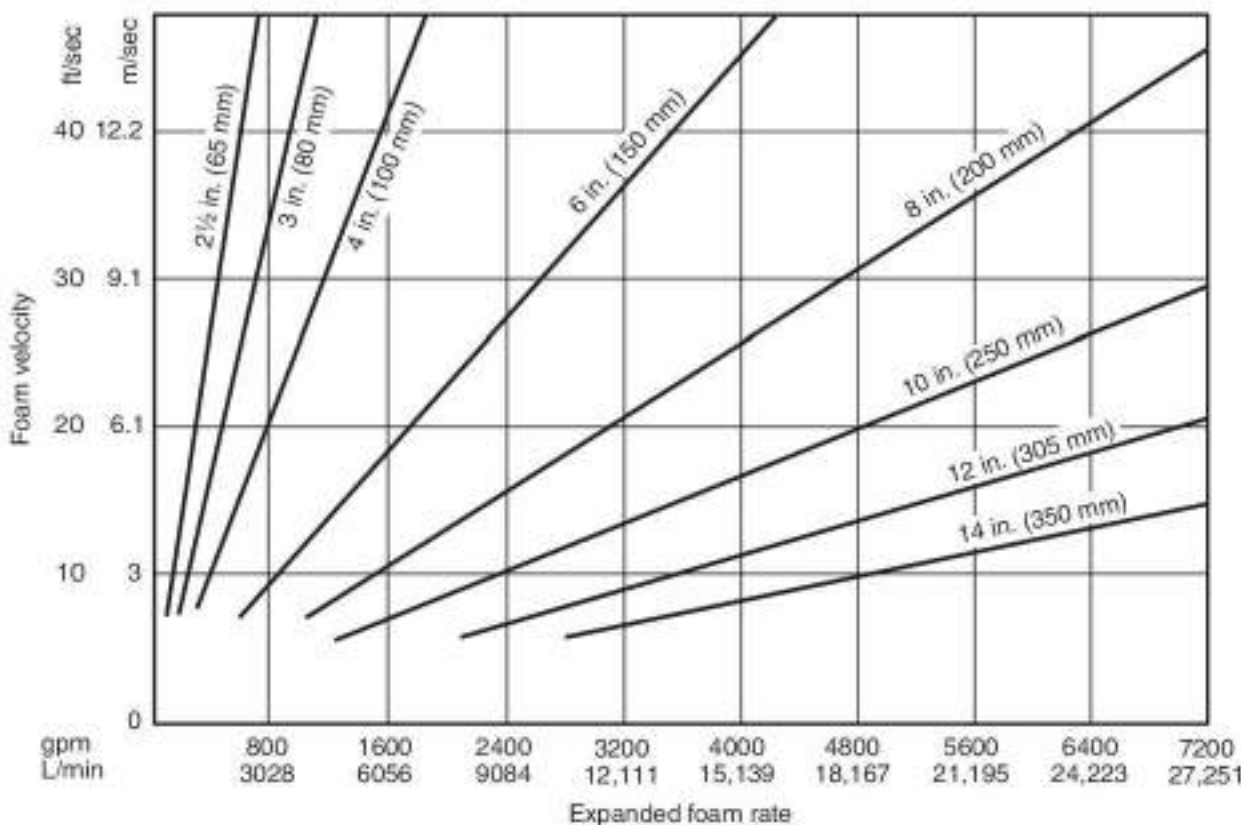
**A.5.2.6.4** The back pressure consists of the static head plus pipe friction losses between the foam maker and the foam inlet to the tank. The friction loss curves, as shown in Figure A.5.2.6.4(a) and Figure A.5.2.6.4(b), are based on a maximum foam expansion of 4, which is the value to be used for friction loss and inlet velocity calculations.

**A.5.2.6.5.2** Liquid hydrocarbons that contain foam-destructive products might require higher application rates. Some foams might fail to extinguish fires in gasolines containing oxygenates where subsurface discharge is used at the usually required rate.

**A.5.2.7** This section describes the design criteria that are applicable to systems used to apply foam to the surface of fixed-roof (cone) storage tanks via a flexible hose rising from the base of the tank. Manufacturer recommendations should be followed for the design and installation of such systems. For semisubsurface system arrangement, see Figure A.5.2.7.

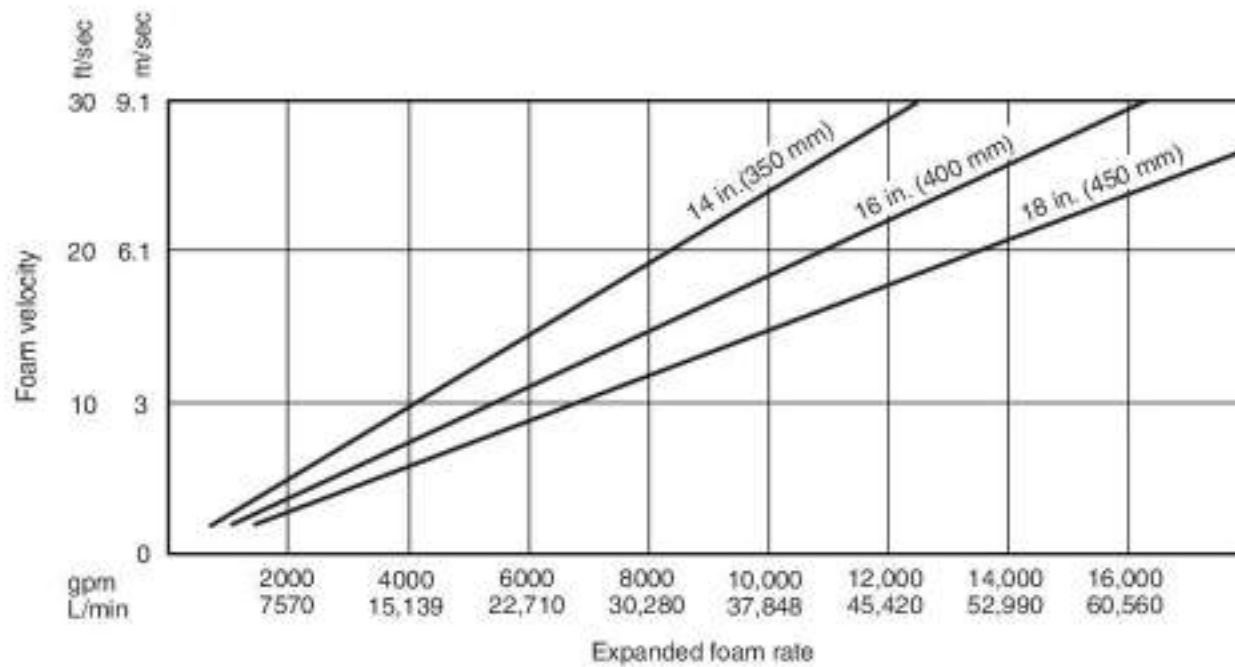


**FIGURE A.5.2.6.1(b)** Typical Connection for Portable High Back-Pressure Foam Maker for Subsurface Application in Semifixed System.



**FIGURE A.5.2.6.2(a)** Foam Velocity vs. Pipe Size [2 1/2 in. (65 mm), 3 in. (80 mm), 4 in. (100 mm), 6 in. (150 mm), 8 in. (200 mm), 10 in. (250 mm), and 12 in. (305 mm)] — Standard Schedule 40 Pipe.





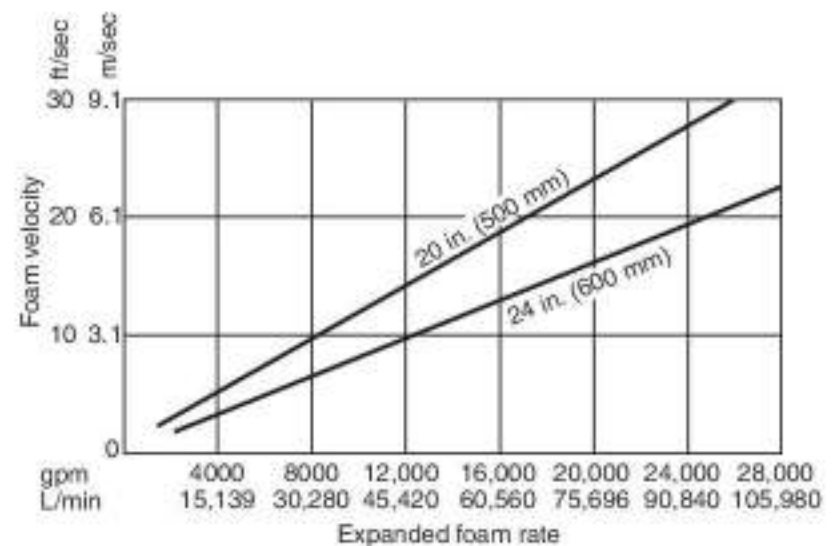
**FIGURE A.5.2.6.2(b) Foam Velocity vs. Pipe Size [14 in. (350 mm), 16 in. (400 mm), and 18 in. (450 mm)] — Standard Schedule 40 Pipe.**

These systems are not considered appropriate for floating roof tanks with or without a fixed roof because the floating roof prevents foam distribution. The flexible foam delivery hose is contained initially in a sealed housing and is connected to an external foam generator capable of working against the maximum product head. When operated, the hose is released from its housing, and the hose floats to the surface as a result of the buoyancy of the foam. Foam then discharges through the open end of the hose directly onto the liquid surface.

Consideration should be given to the following factors when selecting this type of system:

- (1) The total foam output should reach the surface of the burning liquid.
- (2) With large tanks, the semisubsurface units can be arranged to produce an even distribution over the fuel surface.
- (3) Any type of concentrate suitable for gentle surface application to the particular fuel can be used.
- (4) Foam-generating equipment and operating personnel can be located at a distance from the fire.
- (5) The system can be used for the protection of foam destructive liquids, provided the flexible hose is not affected by them.
- (6) Certain high-viscosity fuels might not be suitable for protection by this type of system.
- (7) There is no circulation of the cold fuel and, therefore, no assistance in extinguishment.
- (8) The system can be difficult to check, test, and maintain.
- (9) The high back-pressure foam generator has to produce foam at a pressure sufficient to overcome the head pressure of fuel as well as all friction losses in the foam pipe-work. Friction losses with foam differ from those with foam solution.

Design application rates and discharge times for hydrocarbons are typically the same as for Type II topside application systems [i.e., 0.1 gpm/ft<sup>2</sup> (4.1 mm/min)]. Manufacturers should be consulted for appropriate application rates and design recommendations to be followed for protection of products requiring the use of alcohol-resistant foams.



**FIGURE A.5.2.6.2(c) Foam Velocity vs. Pipe Size [20 in. (500 mm) and 24 in. (600 mm)] — Standard Schedule 40 Pipe.**

Duration of discharge should be in accordance with Table A.5.2.7(a).

Semisubsurface foam units should be spaced equally, and the number of units should be in accordance with Table A.5.2.7(b).

**A.5.3** Within the scope of this standard, open-top floating roof tanks are defined as vertical cylindrical tanks without fixed roofs that have double-deck or pontoon-type floating roofs and are constructed in accordance with the requirements of NFPA 30. The seal can be a mechanical shoe seal or tube seal. The tube seal can be equipped with a metal weather shield. Secondary seals of combustible or noncombustible materials can also be installed. [See Figure 5.3(a) through Figure 5.3(d).]

**A.5.3.1.2(3) LASTFIRE** has developed testing protocols. Examples of other tank construction include full liquid surface contact, metallic sandwich panels and full liquid surface contact, and composite sandwich roof/seal systems, designed

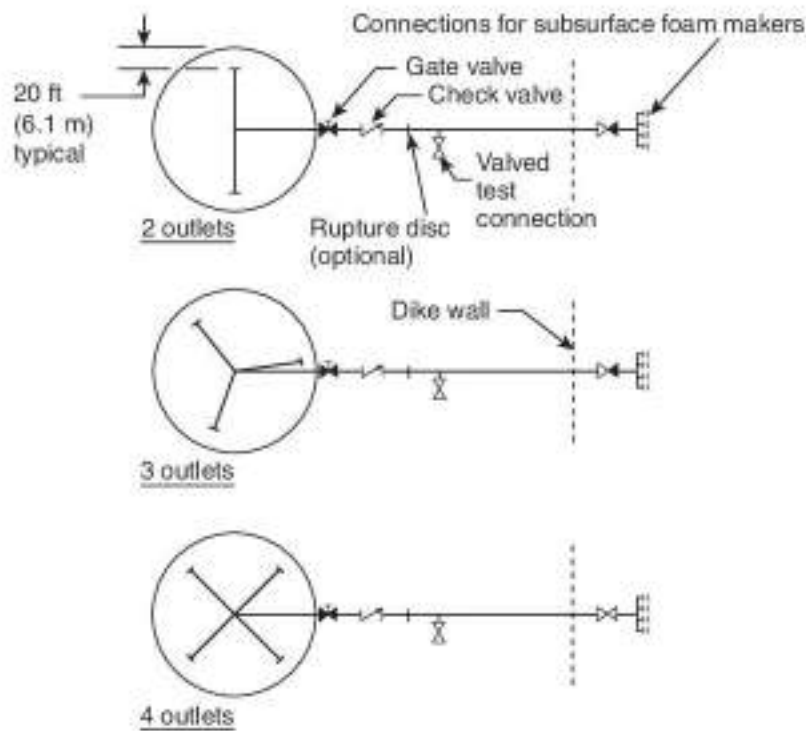


FIGURE A.5.2.6.2(d) Typical Arrangement of Semifixed Subsurface System.

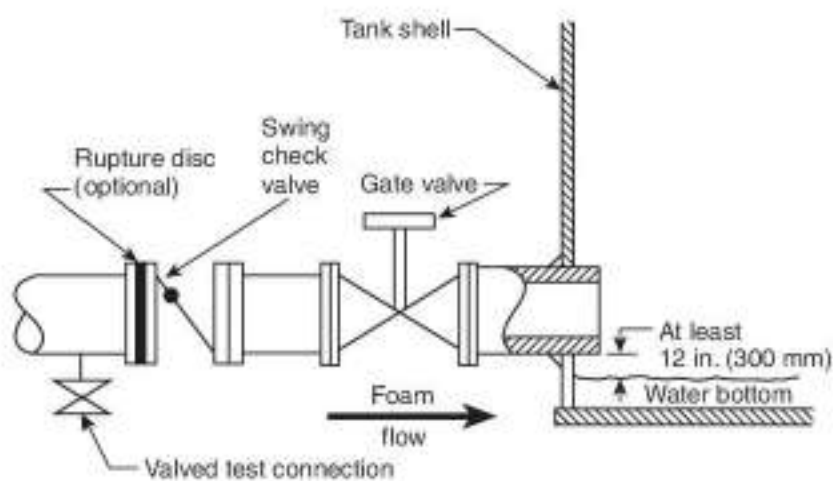


FIGURE A.5.2.6.3 Typical Tank Foam-Maker Discharge Connection for Subsurface Injection.

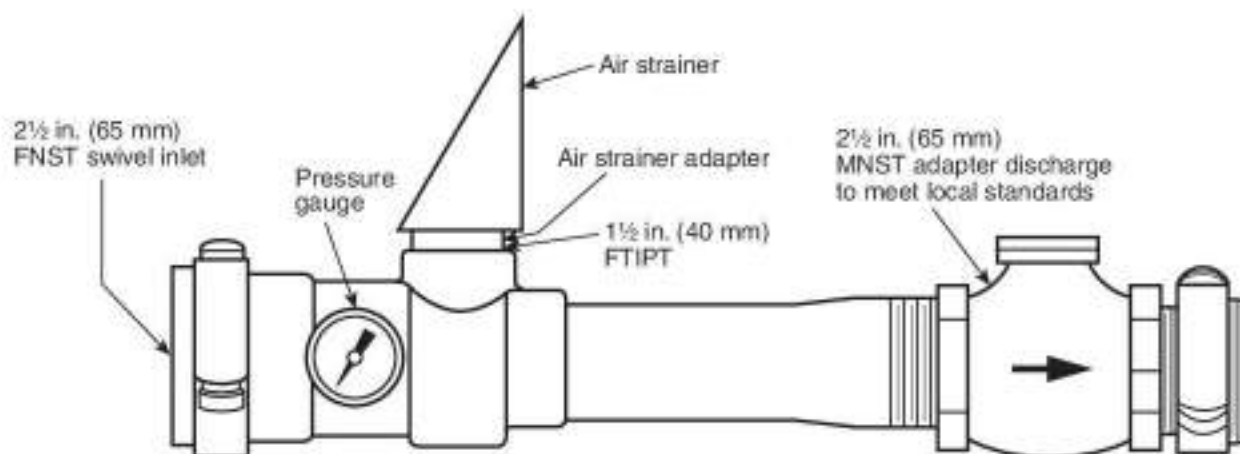


FIGURE A.5.2.6.3.1(a) Portable High Back-Pressure Foam Maker for Semifixed Systems.

in accordance with the performance criteria in Appendix H, "Internal Floating Roofs," of API STD 650.

**A.5.3.3** Open-top floating roof tanks can be subject to two distinct types of fires: a seal fire or a full surface area fire (as a result of the floating roof sinking). Experience indicates that the most frequent type of fire involves only the seal of the floating roof tank. Prior to selection of the method of protection, the type of fire that will serve as the basis for design should be defined. (See NFPA 30 for fire protection requirements.)

Most fires in open-top floating roof tanks occur in the seal areas, and these fires can be extinguished with the foam systems described in Chapter 5. However, some fires involve the full surface area when the roof sinks. These fires are very infrequent and normally do not justify a fixed system to protect for this risk. Plans should be made to fight a full surface fire in a floating roof tank with portable or mobile equipment. Large capacity foam monitor nozzles with capacities up to 6000 gpm (22,700 L/min) are currently available. If foam-proportioning devices are not provided with the foam monitors, additional foam-proportioning trucks might be required through mutual aid. Generally, the number of foam-proportioning trucks available at any location is not sufficient to fight a sunken floating roof fire, and outside assistance is required.

Generally, the fire water systems available in floating roof tank areas are not designed to fight a full surface fire, so additional water is required. Therefore, relay pumping with municipal or mutual aid water pumpers might be required to obtain enough water for foam generation.

Another aspect to consider is the amount of foam concentrate available. The foam application rate of 0.16 gpm/ft<sup>2</sup> (6.5 mm/min) of surface area listed in Chapter 5 might have to be increased for very large tanks. Therefore, the amount of foam concentrate available through mutual aid should be established prior to the fire. In some cases, it can be necessary to increase the on-site foam storage if mutual aid supplies are limited.

If it is decided to fight a fire in a tank with a sunken roof instead of protecting the adjacent facilities and allowing a controlled burnout, the most important aspect is to have planned ahead and held simulated drills. Coordinating the efforts of many different organizations and various pumping operations required for fighting potentially catastrophic fires requires well-developed plans and plenty of practice.

**A.5.3.4.1(3)** It should be recognized that overapplication of foam to a seal area can cause roof tilt and escalate the fire.

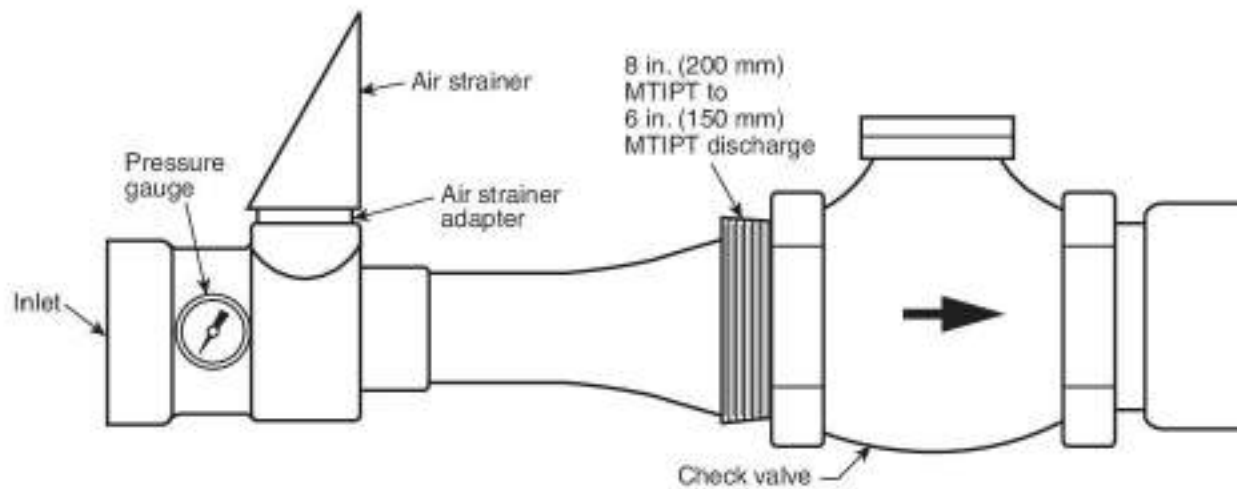


FIGURE A.5.2.6.3.1(b) Fixed High Back-Pressure Foam Maker for Fixed Systems.

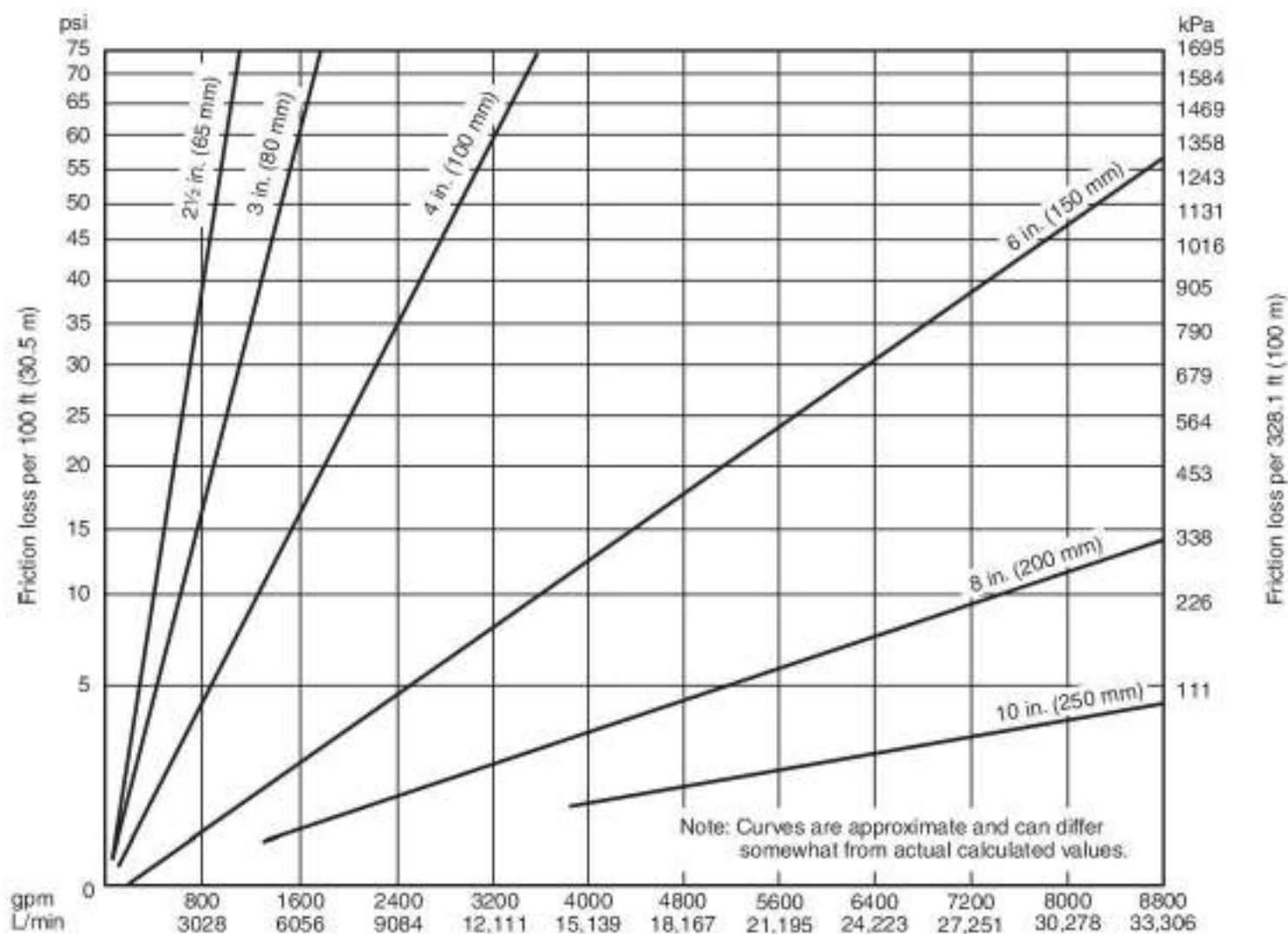


FIGURE A.5.2.6.4(a) Foam Friction Losses — 4 Expansion [2 1/2 in. (65 mm), 3 in. (80 mm), 4 in. (100 mm), 6 in. (150 mm), 8 in. (200 mm), and 10 in. (250 mm)] — Standard Schedule 40 Pipe.

**A.5.3.4.3** The requirements given in this section are based on extrapolations of test experience and appropriate listings and reflect the limitations known to date. Foam can fail to seal against the tank shell as a result of prolonged free burning prior to agent discharge. If adequate water supplies are available, cooling of the tank shell is recommended.

**A.5.3.5.2** See Figure A.5.3.5.2(a) and Figure A.5.3.5.2(b).

**A.5.3.5.2.3** Since all the discharge outlets are supplied from a common (ring) foam solution main, some vapor seal devices might not rupture due to pressure variations encountered as the system is activated. [See Figure A.5.3.5.2(a) and Figure A.5.3.5.2(b).]

**A.5.3.5.4.5** Excessive dam openings for drainage should be prohibited to prevent loss of foam through the drainage slots.

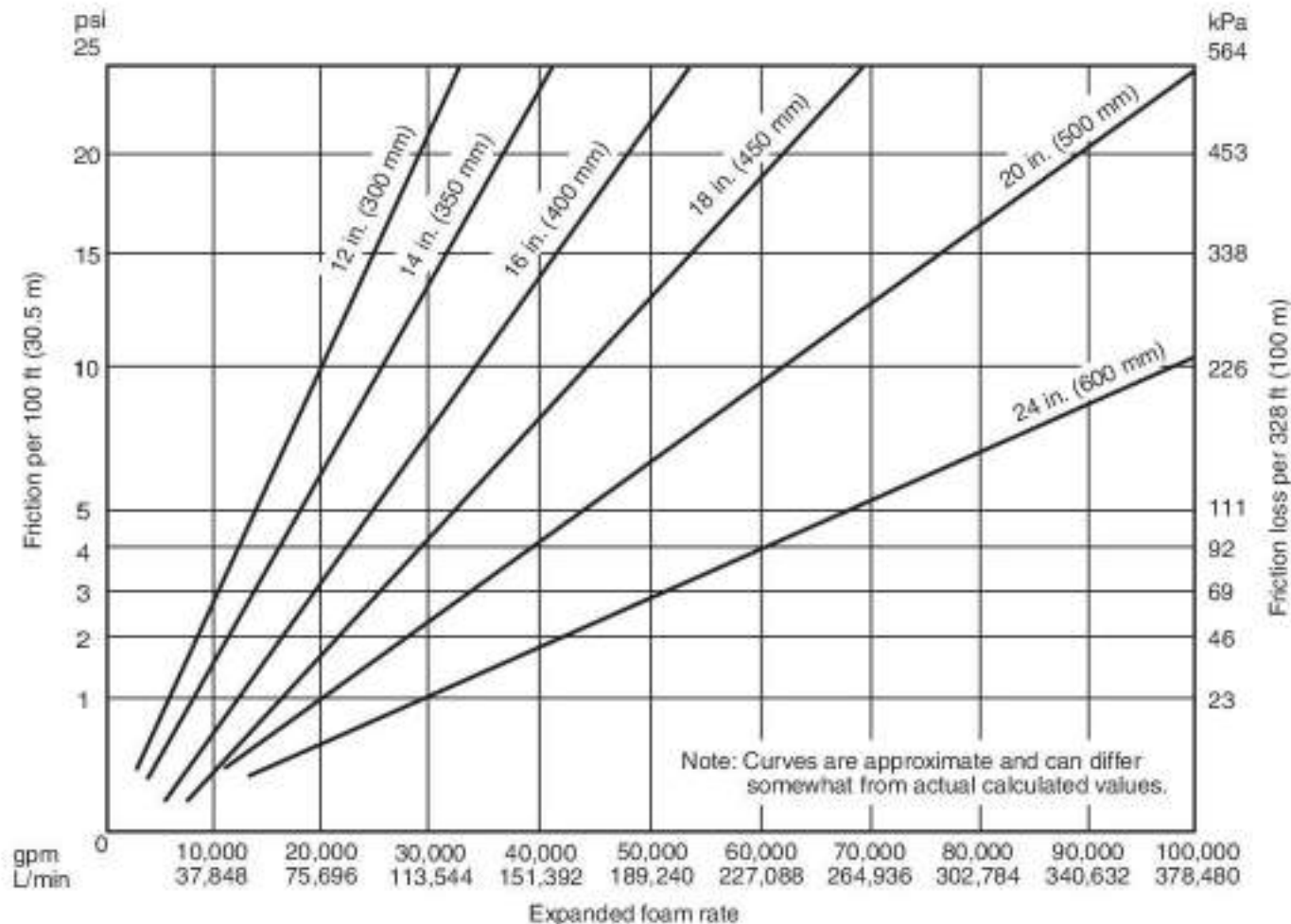


FIGURE A.5.2.6.4(b) Foam Friction Losses — 4 Expansion [12 in. (300 mm), 14 in. (350 mm), 16 in. (400 mm), 18 in. (450 mm), 20 in. (500 mm), and 24 in. (600 mm)] — Standard Schedule 40 Pipe.

**A.5.3.6** Use of foam handlines for the extinguishment of seal fires should be limited to open-top floating roof tanks of less than 250 ft (76 m) in diameter. The following design information applies to foam handline protection methods:

- (1) A foam dam should be installed in accordance with 5.3.5.4.
- (2) To establish a safe base for operation at the top of the tank, a single fixed foam discharge outlet should be installed at the top of the stairs. This fixed foam discharge outlet is supplied to provide coverage of the seal area for approximately 40 ft (12 m) on both sides of the top of the stairs.
- (3) The fixed foam discharge outlet should be designed to discharge at least 50 gpm (190 L/min).
- (4) To permit use of foam handlines from the wind girder, two 1.5 in. (40 mm) diameter valved hose connections should be provided at the top of the stairs in accordance with Figure A.5.3.6. The wind girder should be provided with a railing for the safety of the firefighters.

**A.5.4** Within the scope of this standard, covered (internal) floating roof tanks are defined as vertical cylindrical tanks with a fixed metal roof (cone or geodesic dome) equipped with ventilation at the top and containing a metal double-deck or pontoon-type floating roof or a metal floating cover supported by liquidtight metal flotation devices. They are constructed in accordance with the requirements of NFPA 30. (See Figure 5.4.)

**A.5.4.2** The decision to provide rim seal and/or full surface protection foam systems should include consideration of the tank roof and seal structure and the relative risk associated with

Table A.5.2.7(a) Duration of Discharge for Semisubsurface Systems

Product Stored Foam	Type Minimum	Discharge Time (minutes)
Hydrocarbons with flash point below 100°F (38°C)	Protein, AFFF, fluoroprotein, FFFP, and alcohol-resistant AFFF or FFFP	55
Flash point at or above 100°F (38°C)	All foams	30
Liquids requiring alcohol-resistant foams	Alcohol-resistant foams	55

potential fire scenarios. See Annex I for additional information on the rim seal fire test protocol.

**A.5.4.2(4)** Important fire-resistive properties of these roof/seal systems include:

- (1) Conductive top and bottom surfaces to prevent the buildup of static charge
- (2) Flame spread Class A rating of the top laminate
- (3) Buoyancy in accordance with API STD 650, Appendix H
- (4) Noncombustible material covering the vapor space will limit the spread of a potential rim-seal fire

Table A.5.2.7(b) Minimum Number of Subsurface Units

Tank Diameter		Minimum Number of Semisubsurface Units
ft	m	
Up to 80	Up to 24	1
Over 80 to 120	Over 24 to 37	2
Over 120 to 140	Over 37 to 43	3
Over 140 to 160	Over 43 to 49	4
Over 160 to 180	Over 49 to 55	5
Over 180 to 200	Over 55 to 61	6
Over 200	Over 61	6

Plus 1 outlet for each additional 5000 ft<sup>2</sup> (465 m<sup>2</sup>)

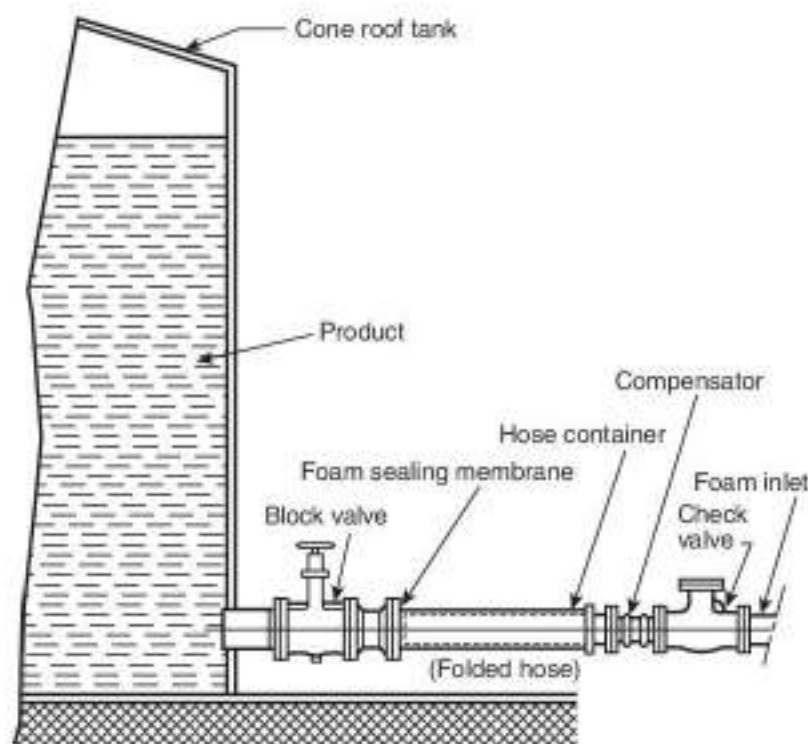


FIGURE A.5.2.7 Semisubsurface System Arrangement.

- (5) Seamless construction with chemical bonds will ensure the roof system maintains its integrity in an explosion, preventing a full-surface fire

**A.5.4.2.3.4** The hazard requiring the highest foam solution flow rate does not necessarily dictate the total amount of foam concentrate required. The requirements given in this section are based on extrapolations of test experience and appropriate listings and reflect the limitations known to date. Foam can fail to seal against the tank shell as a result of prolonged free burning prior to agent discharge. If adequate water supplies are available, cooling of the tank shell is recommended.

**A.5.5.1** For other types of indoor hazards, see the design criteria requirements of NFPA 16.

**A.5.5.4.1** Systems using these foams require special engineering consideration.

**A.5.6** To minimize life and property loss, automation of foam systems protecting a truck loading rack should be taken into account. NFPA 16 states "Foam-water deluge and preaction

systems shall be provided with automatic and auxiliary manual tripping means." [16:4.1.1]

Manual operation only can be provided where acceptable to the AHJ.

There are two methods of automating foam monitor systems for this application:

- (1) Completely automatic detection and actuation (*See applicable sections of NFPA 72 for design criteria.*)
- (2) Actuation by push-button stations or other means of manual release.

The speed of system operation is always critical in minimizing life and property loss.

**A.5.6.5.1** The correct choice of each monitor location is a very important factor in designing a foam monitor system. Traffic patterns, possible obstructions, wind conditions, and effective foam nozzle range affect the design. The appropriate monitors and nozzles should be located so that foam is applied to the entire protected area at the required application rate. Consult the manufacturer of the monitor nozzle for specific performance criteria related to stream range and foam pattern, discharge capacity, and pressure requirements. Manufacturers also should be consulted to confirm applicable listings and/or approvals.

**A.5.7** Generally, portable monitors or foam hose streams or both have been adequate in fighting spill fires in diked areas. In order to obtain maximum flexibility due to the uncertainty of location and the extent of a possible spill in process areas and tank farms, portable or trailer-mounted monitors are more practical than fixed foam systems in covering the area involved. The procedure for fighting diked area spill fires is to extinguish and secure one area and then move on to extinguish the next section within the dike. This technique should be continued until the complete dike area has been extinguished.

**A.5.7.3.2** When using SFFF, the user should refer to Annex H and the manufacturer's recommendations to determine application rates.

**A.5.7.3.3** Fixed foam discharge outlets vary considerably in capacity and range area of coverage.

**A.5.7.3.4.2** Overhead application by foam-water sprinklers or nozzles could require supplementary low-level foam application to provide coverage below large obstructions. Overhead pipework can be susceptible to damage by explosion. Overhead application by foam-water sprinklers or nozzles might require supplementary low-level foam application to provide coverage below large obstructions. Overhead pipework can be susceptible to damage by explosion.

**A.5.7.3.5.3** Low-level foam discharge outlets might require supplementary overhead foam spray application to provide coverage or cooling for overhead structures or for tank surfaces.

**A.5.8** For the purpose of this standard, nondiked spill areas are areas where a flammable or combustible liquid spill can occur, uncontained by curbing, dike walls, or walls of a room or building.

In such cases it is assumed that any fire would be classified as a spill fire [i.e., one in which the flammable liquid spill has an average depth not exceeding 1 in. (25 mm) and is bounded only by the contour of the surface on which it is lying].

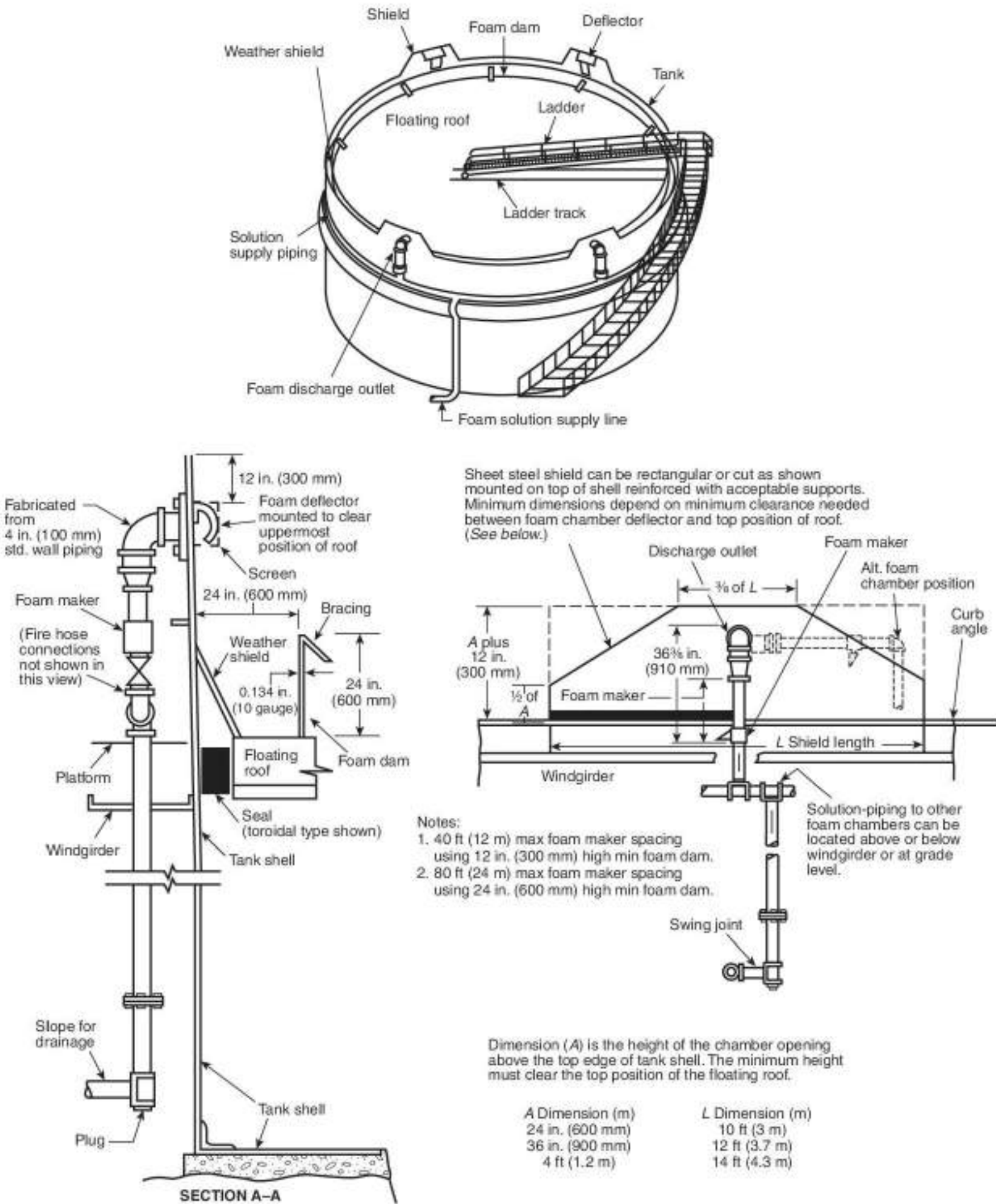
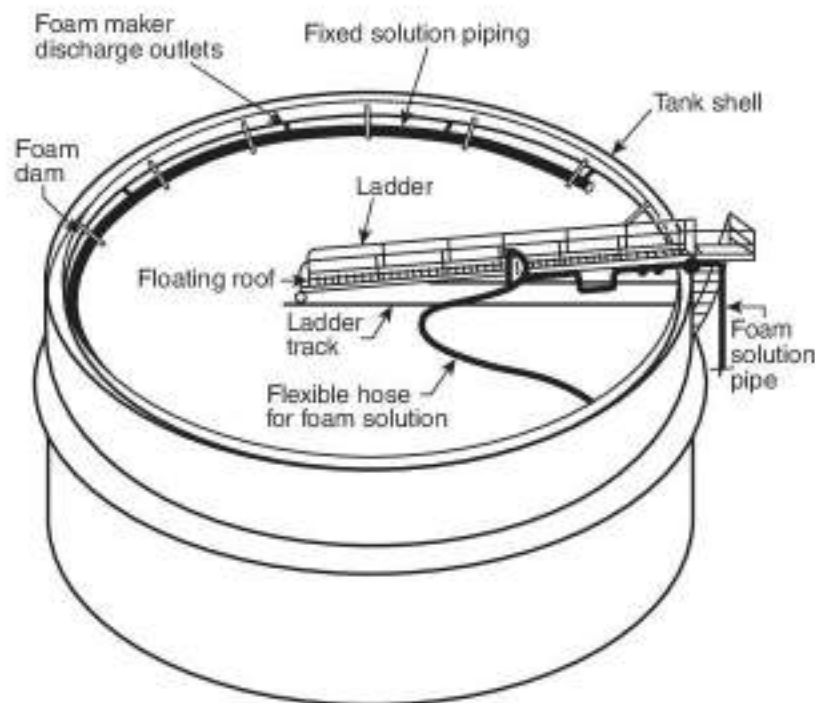


FIGURE A.5.3.5.2(a) Typical Foam Splash Board for Discharge Devices Mounted Above the Top of the Shell.



**FIGURE A.5.3.5.2(b) Fixed Foam Discharge Outlets Mounted on the Periphery of the Floating Roof.**

**A.5.9** Auxiliary foam hose streams can be supplied directly from the main system protecting the tanks (e.g., centralized fixed pipe system) or can be provided by additional equipment. The supplementary hose stream requirements provided herein are not intended to protect against fires involving major fuel spills; rather, they are considered only as first aid-type protection for extinguishing or covering small spills involving areas in square feet (square meters) equal to those covered by about six times the rated capacity [in gpm (L/min)] of the nozzle. Permanently installed foam hydrants, where used, should be located in the vicinity of the hazard protected and in safe and accessible locations. The location should be such that excessive lengths of hose are not required. Limitations on the length of hose that can be used depend on the pressure requirements of the foam nozzle.

**A.6.1.2** The uses of foam (or mechanical foam, as it was first called) for fire protection have increased greatly since it was first used in the 1930s. Original applications of this agent utilized a proteinaceous-type foam-forming liquid concentrate delivered in water solution to a turbulence-producing foam generator or nozzle that then directed the mechanically formed foam to a burning fuel tank or area of burning flammable fuel. (Details of these and similar applications are found in NFPA 402 and NFPA 403.) As the technology for using this agent developed over the years, new systems and new devices for applying the foam to the hazard being protected and new foam-forming liquid concentrates were proven useful for fire protection purposes. The application of foam from overhead sprinkler-type systems using specially designed foam-making nozzles capable of either forming a foam from protein-type foam concentrate solutions or delivering a satisfactory water discharge pattern where supplied with water only was an early development (circa 1954) in foam fire protection. Protein, fluoroprotein, and aqueous film-forming concentrates or film-forming fluoroprotein foam concentrates are suitable for use with foam-water sprinklers. This latter type of foam concentrate also has been found to be suitable for use with standard sprinklers of the type referred to in NFPA 13 where the system is provided with the necessary foam concentrate proportioning

equipment. Care should be exercised to ensure that the choice of concentrate and discharge device are listed for use together.

NFPA 11 is based on available test data and design experience concerning the design information, installation recommendations, operating methods, and maintenance needs for the types of foam-water sprinkler systems previously described and foam-water spray systems utilizing protein, fluoroprotein, or aqueous film-forming foam or film-forming fluoroprotein foam concentrates. These systems possess the common ability to either discharge foam in a spray form or discharge water in a satisfactory pattern for fire protection purposes.

**A.6.1.3.1** Caution should be exercised when auxiliary extinguishing equipment is used with these systems. Some extinguishing agents are incompatible with some foams. The manufacturers should be consulted.

Most foams are not considered suitable extinguishing agents on fires involving liquefied or compressed gases (e.g., butane, butadiene, propane), on materials that will react violently with water (e.g., metallic sodium) or that will produce hazardous materials by reacting with water, or on fires involving electrical equipment where the electrical nonconductivity of the extinguishing agent is of first importance.

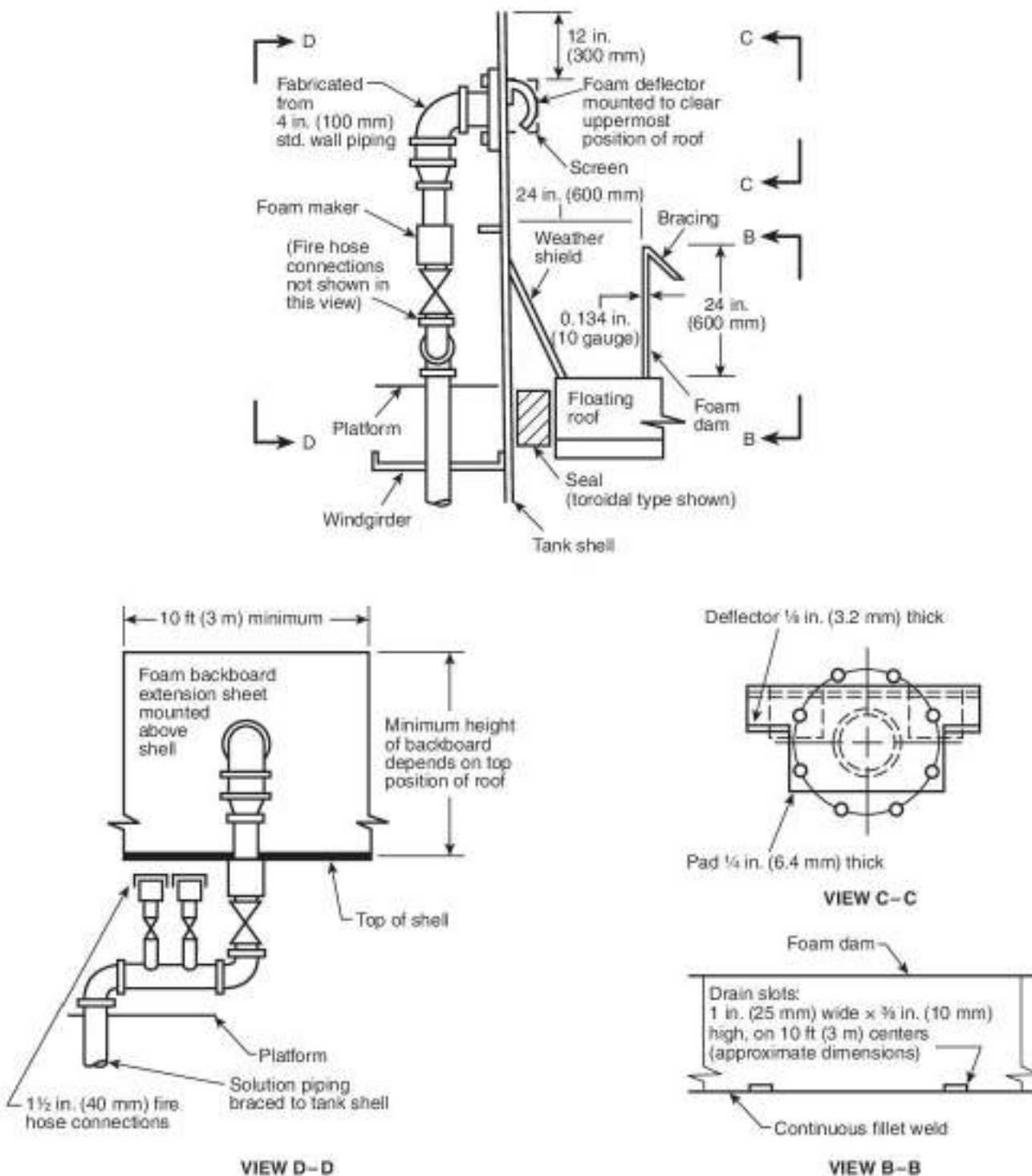
**A.6.1.3.4** Several AFFF and FFFP concentrates have been listed with standard sprinklers for use on nonmiscible hydrocarbons such as heptane, gasoline, fuel oil, crude oils, and so forth, and therefore can be permitted to be used on these products. Polar solvents in depth, such as acetone, methyl ethyl ketone, methyl isobutyl ketone, methanol, ethanol, and isopropanol, have been successfully extinguished with special alcohol-type foam concentrates and standard sprinklers. In all cases, the agent to be used should be determined to be effective on the particular hazardous product by means of listing tests or special testing by the manufacturer where necessary. Application rates can be higher than the required 0.16 gpm/ft<sup>2</sup> (6.5 mm/min) for some specific polar solvents.

**A.6.2.4** The purpose of a reserve supply of concentrate is to have the means available for returning systems to service-ready condition following system operation.

**A.6.2.5** Most test work conducted with closed-head sprinklers has been performed with preprimed systems or systems where foam solution is discharged very quickly — in less than 1 minute. The inherent design philosophy is that foam solution is discharged rapidly on the fuel hazard. Where only water is in the sprinkler piping, the designer and the AHJ should satisfy themselves that the foam solution delay time is acceptable for the given hazard. Factors to consider include the combustible/flammable liquid fuel hazard, associated ordinary combustibles, probable fire growth rate, number of sprinklers expected to operate, and the involvement of commodities at the time of foam discharge. Fire growth factors include flash point of the fuel, water miscibility, container package, and storage height.

Foam concentrate manufacturers generally do not recommend prepriming with foam solution where alcohol-type concentrates are used. The foam concentrate manufacturers should be consulted. The factors cited in the preceding paragraph should then be considered if the system is not preprimed with foam solution. (See A.3.3.17.2.1 for draining and flushing guidance.)

**A.6.4.3** Foam concentrates meeting the requirements of 6.4.3 are available in 3 percent and 6 percent concentrations. Some



**FIGURE A.5.3.6 Typical Installation of Foam Handlines for Seal Area Fire Protection.**

foam concentrates are available for use at temperatures as low as  $-20^{\circ}\text{F}$  ( $-29^{\circ}\text{C}$ ).

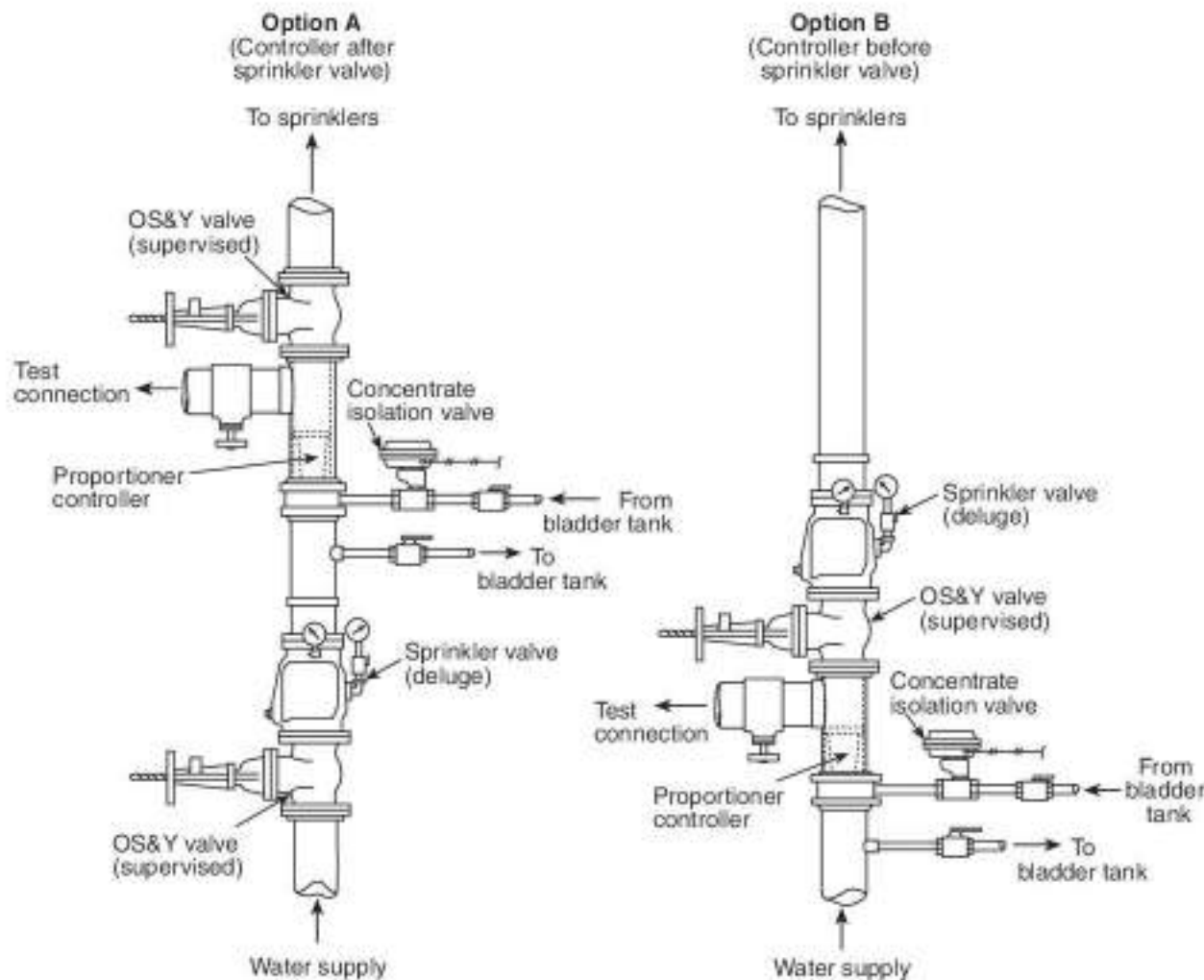
**A.6.4.5** Foam concentrate pumps should have reliability equivalent to that of approved fire pumps. Foam concentrate pumps are generally of the positive displacement variety. Centrifugal pumps might not be suitable for use with foams exhibiting high viscosity characteristics. The foam equipment manufacturer should be consulted for guidance.

**A.6.4.7.2** Some fluoroprotein foam concentrates are incompatible with stainless steel pipe. Check with the manufacturer of the foam concentrate to ensure compatibility of the foam concentrate pipe material.

**A.6.4.7.2.1** Most deluge-type foam water systems are subject to harsh environmental conditions, which can subject the foam solution feed line piping to internal and external corrosion. Types of systems that fall into this category include open head

sprinklers, foam spray nozzles, monitors, foam chambers, fixed foam makers, fixed medium expansion foam makers, and high expansion foam systems. These systems are typically utilized for protection of fuel storage tanks, diked fuel containment areas, LNG facilities, truck and rail car loading racks, aircraft hangars, warehouses, marine docks, interior fuel storage tanks, refineries, and manufacturing/processing areas. The foam solution piping on these systems is exposed to thermal changes, air movement, and other environmental conditions that can cause condensation, and the resulting corrosion can lead to the formation of debris and pipe scale. This material can inhibit proper function of the foam system discharge devices due to blockage. To alleviate the problem of foam systems with piping that is normally open to the surrounding atmosphere, these types of systems are to be constructed using pipe fitting materials identified in 4.7.2.1 and 4.7.3.2.1. Corrosive atmospheres could require other coatings.





Note: Details typical of deluge sprinkler system with bladder-type proportioner.

**FIGURE A.6.4.10** Test Connection Detail.

**A.6.4.7.2.2** See A.4.7.1.2.

**A.6.4.7.2.5** See A.4.7.2.1.

**A.6.4.7.3** Rubber-gasketed fittings subject to direct fire exposure are generally not suitable. Where necessary for piping flexibility or for locations subject to earthquake, explosion, or similar hazards, such installations can be permitted. In such cases, special hanging or bracing might be necessary.

**A.6.4.10** To provide a means of periodically checking the performance of the proportioners used in foam sprinkler systems, a test connection should be provided. Typical test connections are illustrated in Figure A.6.4.10. Two options are possible in locating the proportioning controller in the sprinkler riser: before the main sprinkler valve or after the main sprinkler valve. If the proportioning controller is located after the main sprinkler valve, an additional supervised OS&Y valve is needed to isolate the sprinkler overhead during the proportioner test. The test connection should be routed to a drain area for easy disposal of the solution produced during the test.

**A.6.4.11.1** A minimum of two sprinklers of each type and temperature rating should be provided. [13:A.16.2.7.1]

**A.6.4.11.6** One sprinkler wrench design can be appropriate for many types of sprinklers and should not require multiple wrenches of the same design. [13:A.16.2.7.6]

**A.6.4.11.7.1** The minimum information in the list contained in the spare sprinkler cabinet should be marked with the sprin-

Sprinklers Contained in this Cabinet			
Sprinkler Identification, SIN	General Description	Temperature Rating, °F	Sprinkler Quantity Maintained
TY9128	Extended Coverage, K-25, upright	165	6
VK494	Residential concealed pendent	155	6

Issued: 8/31/19      Revised:

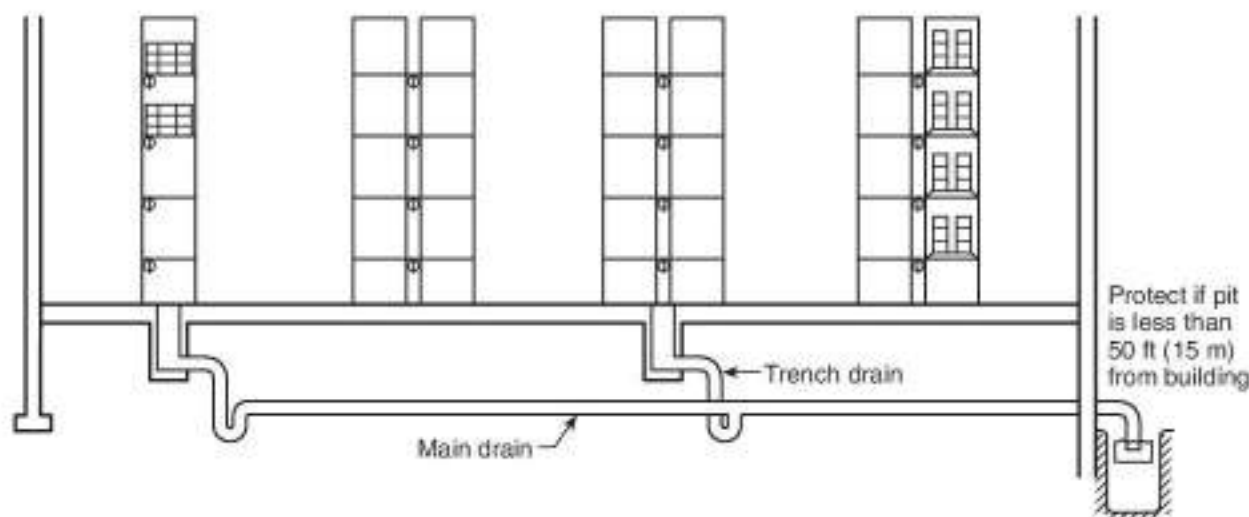
**FIGURE A.6.4.11.7.1** Sample List. [13:Figure A.16.2.7.7.1]

kler identification described in 6.4.11.7.1; a general description of the sprinkler, including upright, pendent, residential, ESFR, and so forth; and the quantity of sprinklers that is to be maintained in the spare sprinkler cabinet. [13:16.2.7.7.1]

An example of the list is shown in Figure A.6.4.11.7.1. [13:A.16.2.7.7.1]

**A.6.5.2.1** For supervision of valves, refer to NFPA 24. See NFPA occupancy standards, where applicable.

**A.6.5.2.2** For protection of some flammable liquids, foam manufacturers might recommend application densities consid-



**FIGURE A.6.5.2.6.1(a) General Scheme for Warehouse Spill Control of Liquids. [30:Figure A.16.8.2(a)]**

erably higher than the minimum densities specified herein or by occupancy standards. These higher application densities generally are a result of specific fire tests performed on a particular fuel and should be considered in a system design. Individual hazards might require minimum discharge pressures to adequately compensate for environmental effects such as wind. See NFPA 15 for additional information.

**A.6.5.2.2.2.1(A)** The design area can only be modified by occupancy standards, such as NFPA 409. The design area modifiers of NFPA 13 for remote area increases or decreases, such as increases for dry-pipe or double-interlock systems and sloped ceilings, and reductions for the use of quick-response sprinklers, are not intended to be applied to any NFPA 11 system.

**A.6.5.2.5.1** Where piping integrity is checked by pressurization from a jockey pump or other suitable means, care should be taken to prevent overpressurization of system components and piping. A suitable means of pressure relief should be provided if necessary.

**A.6.5.2.6.1** Section 16.8 of NFPA 30 requires that control of liquid spread be provided to prevent a pool fire on the floor from spreading and opening more sprinkler than the design of the sprinkler system anticipates. For example, if the foam-water sprinkler system is designed to provide 0.45 gpm/ft<sup>2</sup> over 3000 ft<sup>2</sup> (18 mm/min over 280 m<sup>2</sup>), 16.8.2 of NFPA 30 requires that the spread of liquid also be limited to 3000 ft<sup>2</sup> (280 m<sup>2</sup>). Various means are available to achieve this control. [30:A.16.8.2]

Typical methods use trench or spot drains that divide the floor of the storage area into rectangles having areas equal to or less than the design area of the sprinkler system. Drains are centered under racks, and the floor is sloped toward the drain trenches with a minimum slope of 1 percent. The floor is made highest at the walls. See Figure A.6.5.2.6.1(a) and Figure A.6.5.2.6.1(b). Trenches are arranged as described in NFPA 15 and as shown in Figure A.6.5.2.6.1(c). Note particularly the dimensions of the trenches, and note that the solid covering spans one-third of the width on either side of the open grate and the open grate spans the middle third. Spot drains can be similarly arranged. Another method, shown in Figure A.6.5.2.6.1(d), uses spot drains located at building columns, where the area between any four columns does not exceed the design area of the sprinkler system. The floor is sloped to direct water flow to the drains. [30:A.16.8.2]

Connections to the drains are provided at trapped sumps, arranged as described in NFPA 15. See Figure A.6.5.2.6.1(e). To provide a safety factor, the drain pipes are sometimes sized to carry 150 percent of anticipated sprinkler discharge. The following equation can be used to calculate the flow of the drain pipe:

$$F = 1.5DA \quad [\text{A.6.5.2.6.1}]$$

where:

$F$  = flow (gpm or L/min)

$D$  = sprinkler design density (gpm/ft<sup>2</sup> or L/min/m<sup>2</sup>)

$A$  = sprinkler design area (ft<sup>2</sup> or m<sup>2</sup>)

[30:A.16.8.2]

Additional information can be found in *Guidelines for Safe Warehousing of Chemicals*, Center for Chemical Process Safety, American Institute of Chemical Engineers. [30:A.16.8.2]

A foam-water sprinkler system requires the following containment volume:

In U.S. units:

$$0.16 \text{ gpm/ft}^2 \times 5000 \text{ ft}^2 + 250 \text{ gpm} = 1050 \text{ gpm}$$

$$1050 \text{ gpm} \times 60 \text{ min} = 63,000 \text{ gal} + \text{volume of liquid in gal}$$

In SI units:

$$6.5 \text{ mm/m}^2 \times 465 \text{ m}^2 + 946 \text{ L/min} = 3969 \text{ L/min}$$

$$3969 \text{ L/min} \times 60 \text{ min} = 238,140 \text{ L} + \text{volume of liquid in L}$$

**A.6.5.8.1.1** The spacing of automatic detection equipment for systems installed for protection against fire exposure might call for an arrangement different from that required for other types of systems.

**A.6.5.8.5** See *NFPA 70*, Chapter 5, particularly Article 500.

**A.6.5.9.1** Wherever practicable, the fire department connection to the foam-water sprinkler system should be separate from the normal building fire sprinkler system. Signs and placards could be appropriate to alert the fire department.

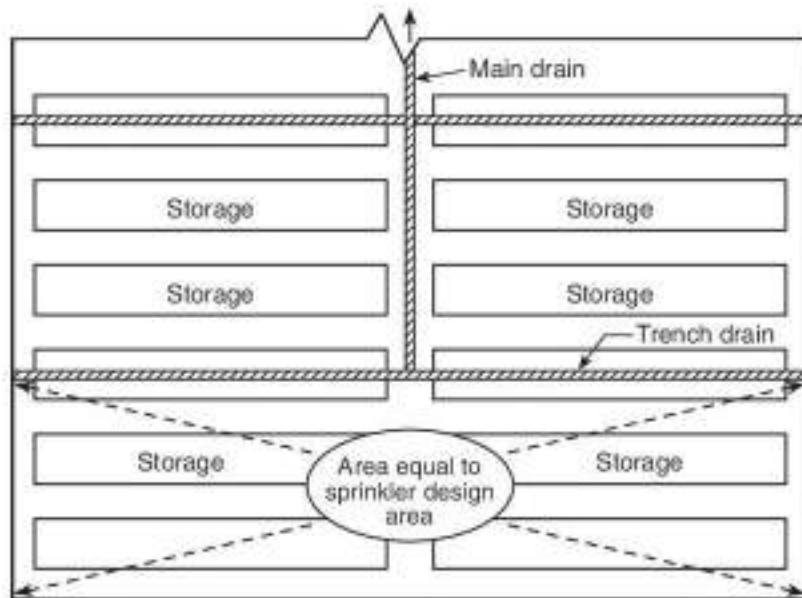


FIGURE A.6.5.2.6.1(b) Plan View of Warehouse Spill Control of Liquids. [30:Figure A.16.8.2(b)]

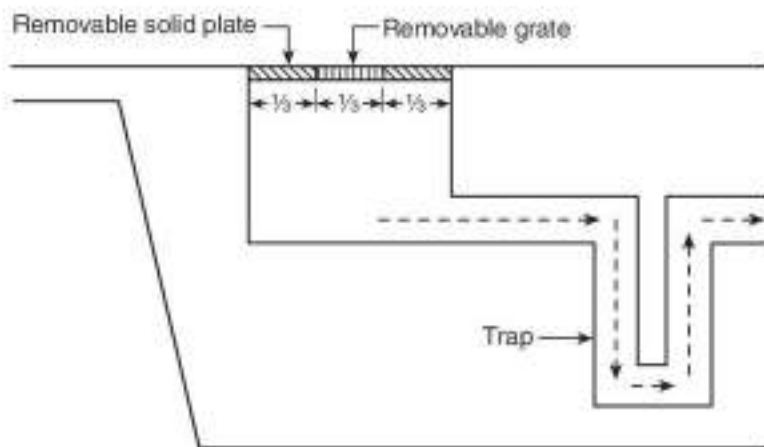
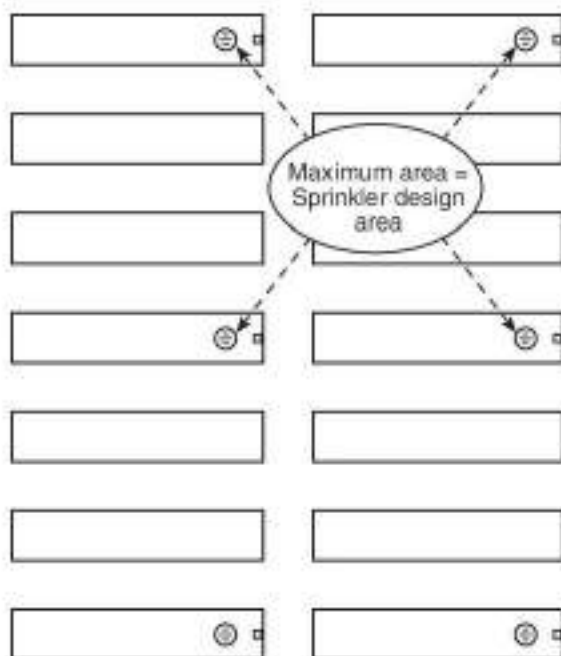


FIGURE A.6.5.2.6.1(c) Details of Drainage Trench Design. [30:Figure A.16.8.2(c)]



Key:  
 ⊙ Drain   □ Column

FIGURE A.6.5.2.6.1(d) Typical Arrangement of Floor Drains. [30:Figure A.16.8.2(d)]

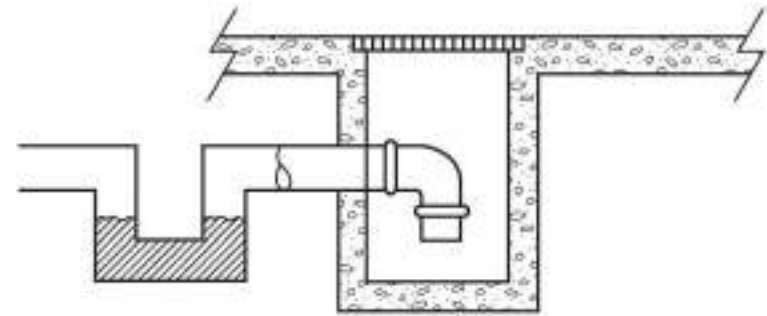


FIGURE A.6.5.2.6.1(e) Details of Liquid-Seal Trap. [30:Figure A.16.8.2(e)]

**A.6.5.10.1.4** The friction losses in piping carrying foam concentrate can be calculated by using the Darcy-Weisbach formula, also known as the Fanning formula.

For U.S. customary units:

Darcy formula:

$$\Delta P = 0.000216 \left( \frac{f \rho Q^2}{d^5} \right)$$

Reynolds number:

[A.6.5.10.1.4a]

$$\Delta R = \frac{50.6 Q \rho}{d \mu}$$

where:

$\Delta P$  = friction loss (psi)

$f$  = friction factor

$L$  = length of pipe (ft)

$\rho$  = weight density of fluid (lb/ft<sup>3</sup>)

$Q$  = flow (gpm)

$d$  = pipe diameter (in.)

$R$  = Reynolds number

$\mu$  = absolute (dynamic) viscosity (cP)

For SI units:

Darcy formula:

[A.6.5.10.1.4b]

$$\Delta P_s = 2.252 \left( \frac{f \rho Q^2}{d^5} \right)$$

Reynolds number:

$$\Delta R_s = 21.22 \left( \frac{Q \rho}{d \mu} \right)$$

where:

$\Delta P_s$  = friction loss (bar)

$f$  = friction factor

$L$  = length of pipe (m)

$\rho$  = density of fluid (kg/m<sup>3</sup>)

$Q$  = flow (L/min)

$d$  = pipe diameter (mm)

$R$  = Reynolds number

$\mu$  = absolute (dynamic) viscosity (cP)

**A.6.5.10.1.4.4** The Darcy-Weisbach formula is suitable for Newtonian fluids; however, some alcohol-resistant foams are non-Newtonian fluids. The foam manufacturer should be consulted for friction losses in alcohol-resistant foams.

**A.6.5.10.2.2** Where the specified areas of demand are selected close to the source of supply, the higher available pressures can increase the flow beyond the capacity of the foam proportioning equipment.

**A.6.5.10.2.3** Where excessive variations exist between calculated demand and available water supply, the actual excess discharge can exceed the capacity of the foam system to operate for the minimum 7-minute run time. A verification calculation should be made as follows:

Multiply the actual predicted system flow by the foam concentrate percentage, then divide this answer into the foam quantity as determined in 6.5.2.3.1. The time indicated should be 7 minutes or greater.

**A.7.1** Medium- and high-expansion foam extinguishes fire by reducing the concentration of oxygen at the seat of the fire, by cooling, by halting convection and radiation, by excluding additional air, and by retarding flammable vapor release. (See Annex C.)

**A.7.3** Use of high-expansion foam for polar solvents should be proven by fire tests using polar solvents that are to be used in the protected area.

**A.7.3.2** Under certain circumstances, it might be possible to utilize medium- or high-expansion foam systems for control of fires involving flammable liquids or gases issuing under pressure, but no general recommendations can be made in this standard due to the infinite variety of particular situations that can be encountered in actual practice. Ability to control or extinguish a fire in a given hazard might depend on such factors as expansion, drainage, and fluidity. These factors will vary with the concentrate, equipment, water supply, and air supply.

**A.7.6** The discharge of large amounts of medium- or high-expansion foam can inundate personnel, while blocking vision, making hearing difficult, creating some discomfort in breathing, and causing spatial disorientation. This breathing discomfort will increase with a reduction in expansion ratio of the foam while the foam is under the effect of sprinkler discharge.

**A.7.6.1** Additional exits and other measures might be necessary to ensure safe evacuation of personnel.

**A.7.6.2** The following information is provided as a best practice for conducting search and rescue in a foam-filled aircraft hangar. The use of life-lines is not recommended as they can become entangled in obstacles hidden beneath the foam. The foam environment will create a total sensory deprivation for rescue personnel. Thermal imaging cameras are ineffective in locating victims.

**A.7.6.2.2** Water should be applied utilizing handlines and aircraft rescue and firefighting vehicle turrets in an indirect, semi-fog pattern, application method aimed above the foam, discharging side to side creating a raindrop effect. Mass application of water will knock-down the top layer of foam creating a foam/water slurry. The application of industrial silicone-based de-foaming agent through a handline (direct method) metered at 6 percent, utilizing a foam eductor, will effectively disperse the foam slurry.

**A.7.6.2.3** Rescue personnel should line up abreast of each other so as to have search wand overlap. Rescue personnel should conduct primary and secondary searches to ensure methodical coverage of the facility. In aircraft hangars, the search pattern should start at the center of the hangar bay as this area will have initial agent application. Note that a search wand can be a simple 6 ft (1.8 m) piece of PVC pipe. See Figure A.7.6.2.3(a) through Figure A.7.6.2.3(d).

**A.7.6.2.3.1** Portable radios might not work under foam blanket; therefore, rescue personnel should make entry when they have line-of-sight with each other to ensure effective communications.

**A.7.6.3** As used in this standard, "clearance" is the air distance between medium- or high-expansion foam equipment, including piping and nozzles, and unenclosed or uninsulated live electrical components at other than ground potential. Since medium- or high-expansion foams are conductive, these clearances do not prevent conduction through foam. (See 7.6.1.3.) Up to electrical system voltages of 161 kV, the design BIL kV and corresponding minimum clearances, phase to ground, have been established through long use.

**A.7.6.3.2.1** The clearances are based on minimum general practices related to design basic insulation level (BIL) values.

**A.7.7.1** Fires or conditions likely to produce fire can be detected by human senses or by automatic means.

**A.7.7.1.1.1** In outdoor locations with minimal or no exposures or life hazards, such as LNG spill retention areas, immediate detection and suppression of a fire is not critical for protection of life and property. Detection by personnel and manual operation of a fixed system is considered acceptable.

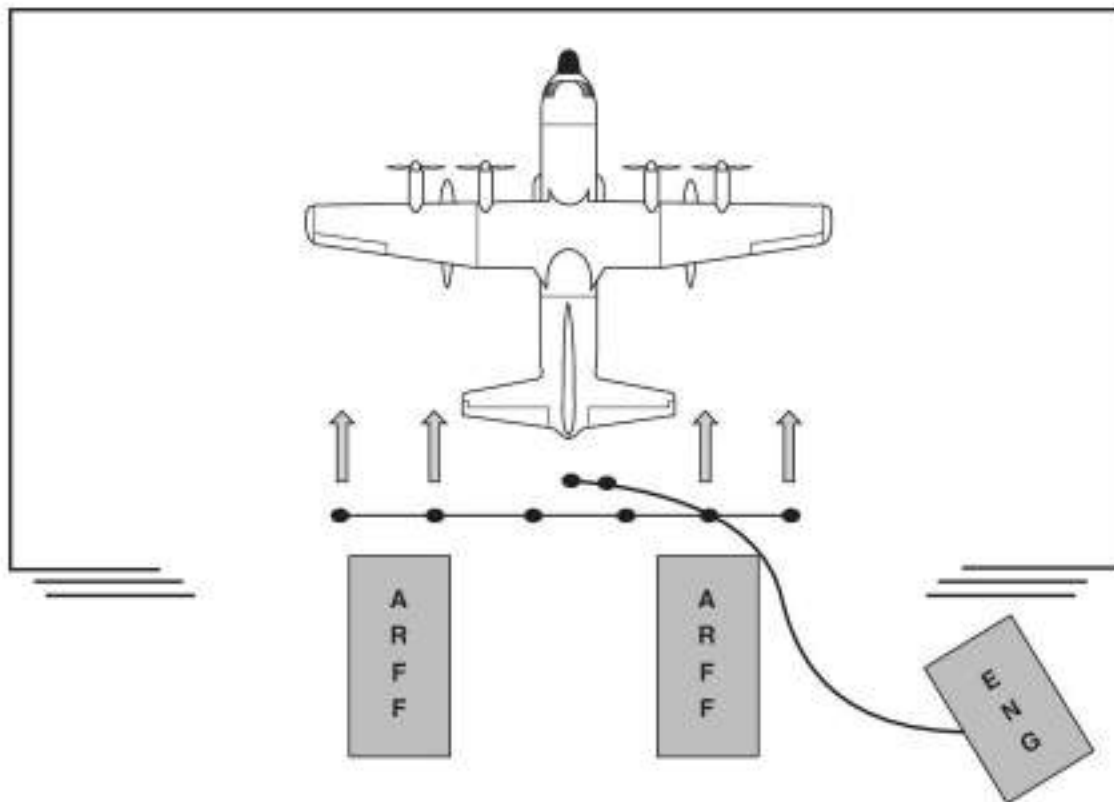
**A.7.7.1.2** See *NFPA 72*.

**A.7.7.1.4** See applicable provisions of *NFPA 72* for power supply requirements.

**A.7.7.4** A block diagram of a typical automatic medium- or high-expansion foam system is shown in Figure A.7.7.4(a). At the present time, foam generators for medium- and high-expansion foam are of two types, depending on the means for introducing air — by aspirator or blower. In either case, the properly proportioned foam solution is made to impinge at appropriate velocity on a screen or porous or perforated membrane or series of screens in a moving airstream. The liquid films formed on the screen are distended by the moving airstream to form a mass of bubbles or medium- or high-expansion foam. The foam volume varies from about 20 to 1000 times the liquid volume, depending on the design of the generator. The capacity of foam generators is generally determined by the time required to fill an enclosure of known volume by top application within 1 minute to 5 minutes.

*Foam Generators — Aspirator Type.* Aspirator-type foam generators can be fixed or portable. Jet streams of foam solution aspirate sufficient amounts of air that is then entrained on the screens to produce foam. [See Figure A.7.7.4(b).] These generators usually produce foam with expansion ratios of not more than 250:1.

*Foam Generators — Blower Type.* Blower type foam generators can be fixed or portable. The foam solution is discharged as a spray onto screens through which an airstream developed by a fan or blower is passing. The blower can be powered by electric motors, internal combustion engines, air, gas, or hydraulic



**FIGURE A.7.6.2.3(a)** Beginning at Hangar Center Where Initial Foam Knockdown Occurs, Conduct Primary and Secondary Searches of the Facility.

motors or water motors. The water motors are usually powered by foam solution. [See Figure A.7.7.4(c).]

**A.7.10.2** To determine its ability to withstand fire exposure from the hazard area, a generator and its associated piping and electrical wiring, protected in accordance with the manufacturers' recommendations, should be started and operated satisfactorily after a 5-minute exposure 10 ft (3 m) above a 50 ft<sup>2</sup> (4.6 m<sup>2</sup>) *n*-heptane fire using 100 gal (380 L) of fuel. The test fire should be shielded to ensure flame impingement on the generator.

**A.7.12.2** Examples of hazards that can be permitted to be successfully protected by total flooding systems include rooms, vaults, storage areas, warehousing facilities, and buildings containing Class A and Class B combustibles either singly or in combination.

See NFPA 13.

**A.7.12.4.1** To assure the efficiency of a total flowing medium- or high-expansion foam system, the development and maintenance of a suitable quantity of foam within the particular enclosure to be protected is required. Leakage from the enclosure area should be avoided by sealing openings with doors and windows that close automatically.

**A.7.12.7.1** It is imperative that the integrity of primary structural members be maintained under fire exposure (which, in sprinklered structures, normally support the sprinkler system). Light, unprotected bar joists, and other similar types of supports are especially vulnerable to damage by fast-developing fires as compared to supports in heavy steel construction. Heavy, unprotected steel framing is also more vulnerable than fire-resistive (concrete) or protected structural members.



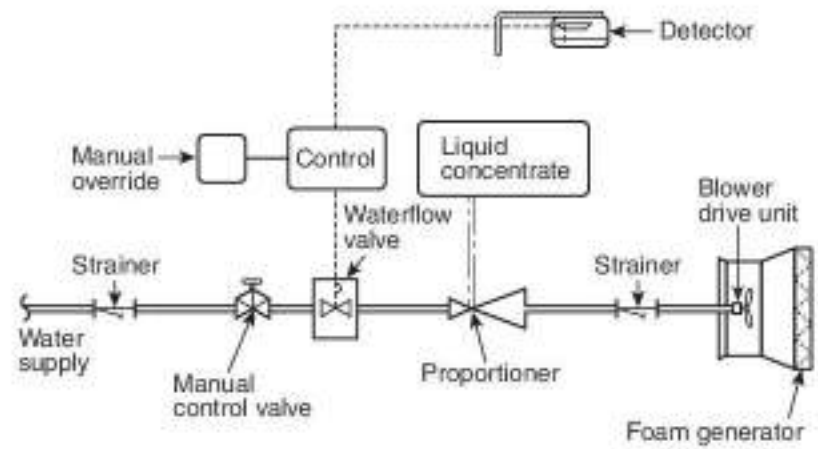
**FIGURE A.7.6.2.3(b)** Firefighters Lined up Abreast of Each Other Moving Methodically Through the Foam.

**A.7.12.8** Tests with foams of above 400:1 expansion ratio have shown that extinguishment times for flammable liquid fires increased significantly at rates of foam rise less than 3 ft/min (0.9 m/min). It is expected that at some expansion ratio below 400:1, lower rates of foam rise would be adequate, but insufficient tests have been conducted to identify this ratio.

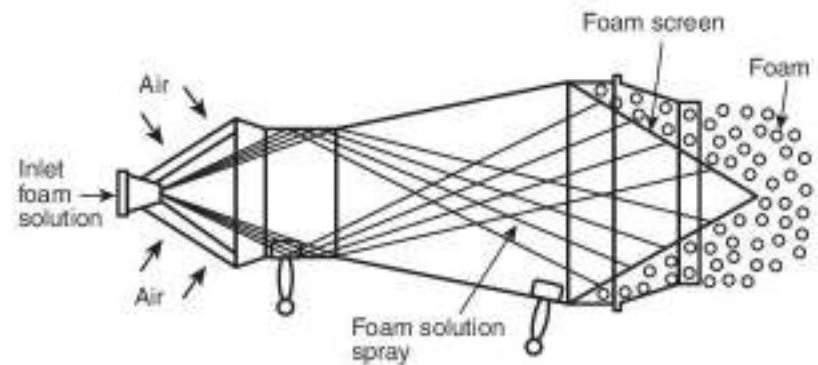
**A.7.12.8.2.1** The rate also depends on foam properties, such as expansion ratio, water retention, effect of water contaminants, and temperature effects on water retention.



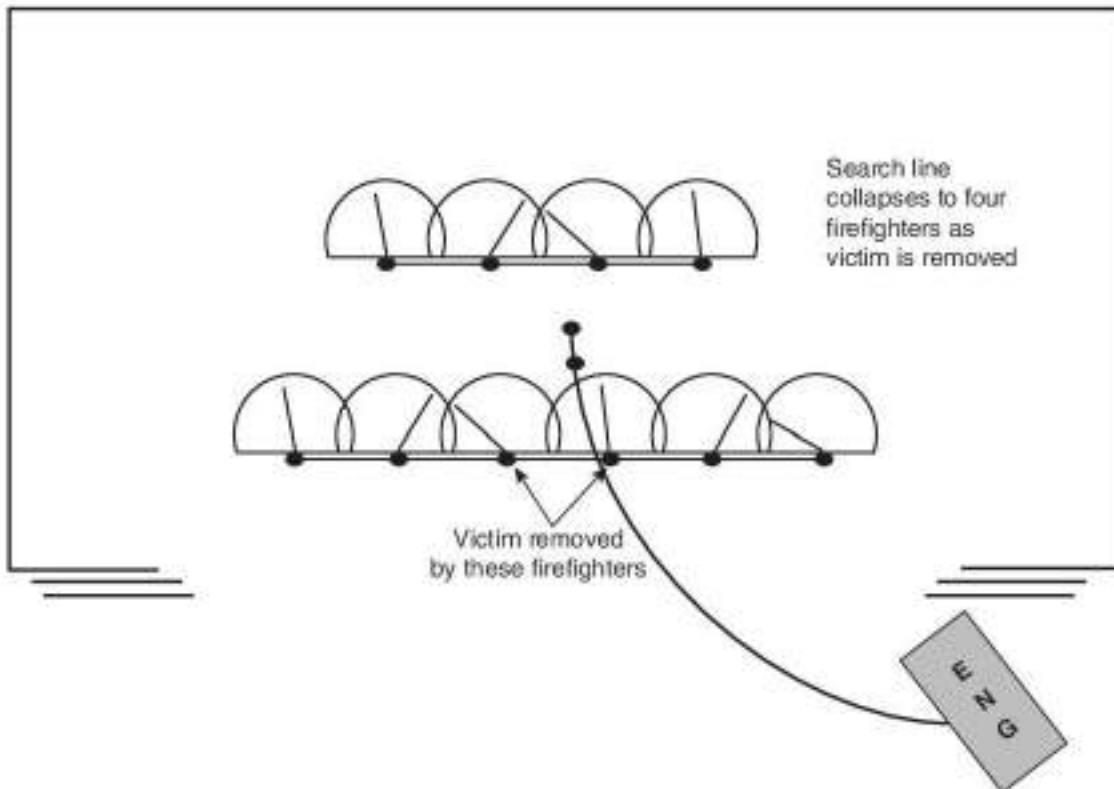
**FIGURE A.7.6.2.3(c)** Firefighters Sweeping 6 ft (1.8 m) Wands in a 180-Degree Motion Searching for Anything Hidden Beneath the Foam.



**FIGURE A.7.7.4(a)** Block Diagram of Automatic Medium- or High-Expansion Foam System.



**FIGURE A.7.7.4(b)** Aspirating-Type Foam Generator.



**FIGURE A.7.6.2.3(d)** Search Line Shrinking and Continuing Forward After Victims Are Found and Removed.

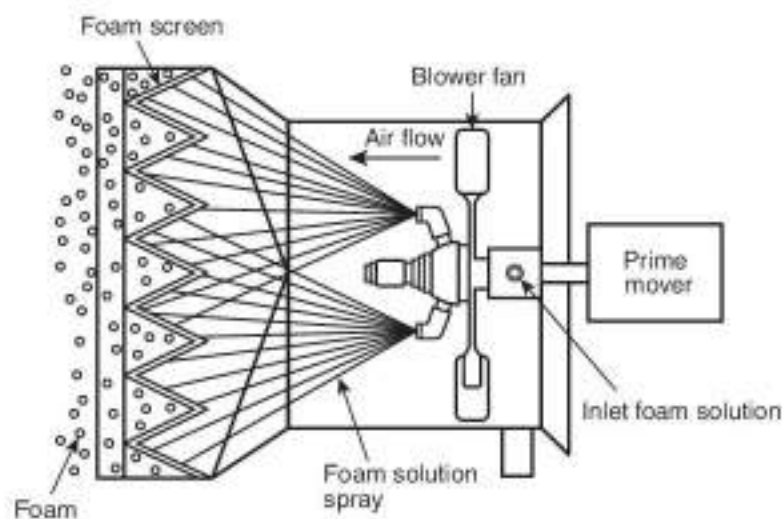
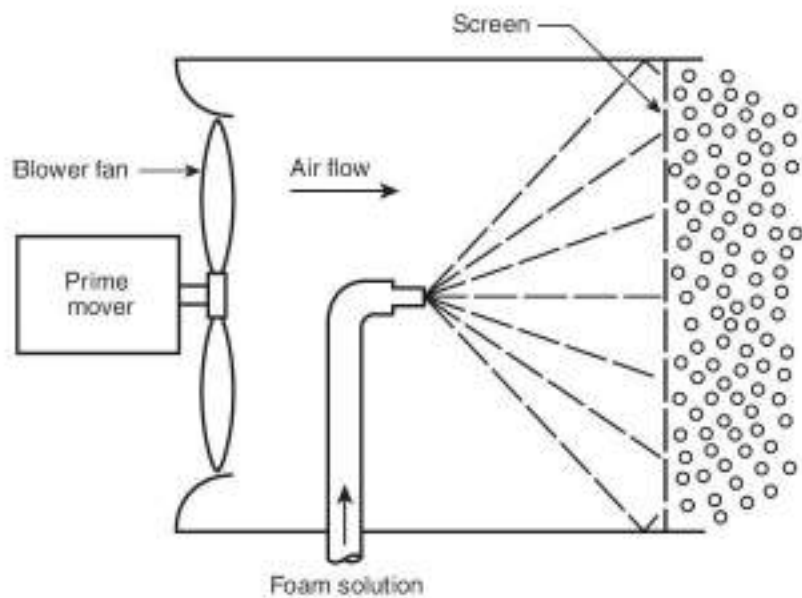


FIGURE A.7.7.4(c) Blower-Type Foam Generators.

**A.7.12.8.2.3.1** The following are sample calculations of total high-expansion foam generator capacity:

*Calculation Using U.S. Units*

- (1) Given: Building size — 100 ft × 200 ft × 30 ft high.
- (2) Building construction — Light bar joist, Class I steel deck roof, adequately vented. Masonry walls with all openings closable.
- (3) Sprinkler protection — Wet system 10 ft × 10 ft spacing, 0.25 gpm/ft<sup>2</sup> density.
- (4) Occupancy — Vertically stacked unbanded rolled kraft paper 25 ft high.
- (5) Assume: Fire will open 50 sprinkler heads. Foam leakage around closed doors, drains, and so forth, hence  $C_l = 1.2$ .
- (6) Calculation
  - (a) Foam depth: Depth = 25 × 1.1 = 27.5 ft (This depth is greater than minimum cover of 2 ft.)
  - (b) Submergence volume:  $V = 100 \times 200 \times 27.5 = 550,000 \text{ ft}^3$
  - (c) Submergence time:  $T = 5$  minutes (from Table 7.12.7.1)
  - (d) Rate of foam breakdown by sprinklers:
 
$$S = 10 \text{ ft}^3/\text{min} \cdot \text{gpm} \text{ [from 7.12.8.2.3.2]}$$

$$Q = \text{Number of heads} \times \text{area/head} \times \text{density}$$

$$= 50 \times (10 \times 10) \times 0.25 = 1250 \text{ gpm}$$

$$R_s = S \times Q = 10 \times 1250 = 12,500 \text{ ft}^3/\text{min}$$

- (e) Normal foam shrinkage:  $C_N = 1.15$  [from 7.12.8.2.3.3]
- (f) Leakage:  $C_l = 1.2$  (assumption)
- (g) Total generator capacity

[A.7.12.8.2.3.1a]

$$R = \left( \frac{V}{T} + R_s \right) \times C_N \times C_l$$

$$R = \left( \frac{550,000}{5} + 12,500 \right) \times 1.15 \times 1.2$$

$$R = 169,000 \text{ ft}^3/\text{min}$$

The number of generators required will depend upon the capacity of the generators available.

*Calculation Using SI Units*

- (1) Given: Building size — 30 m × 61 m × 9.1 m high.
- (2) Building construction — Same as U.S. units calculation.
- (3) Sprinkler protection — Wet system 3 m × 3 m spacing, 10.2 mm/min density.
- (4) Occupancy — Vertically stacked unbanded rolled kraft paper 7.6 m high.
- (5) Assume: Same assumption as U.S. units calculation.
- (6) Calculation
  - (a) Foam depth: Depth = 7.6 × 1.1 = 8.4 m (This depth is greater than minimum cover of 0.6 m.)
  - (b) Submergence volume:  $V = 30.5 \times 61 \times 8.4 = 15,628 \text{ m}^3$
  - (c) Submergence time:  $T = 5$  minutes (from Table 7.12.7.1)
  - (d) Rate of foam breakdown by sprinklers:
 
$$S = 0.0748 \text{ m}^3/\text{min} \cdot \text{L}/\text{min} \text{ [from 7.12.8.2.3.2]}$$

$$Q = \text{Number of heads} \times \text{area/head} \times \text{density}$$

$$= 50 \times (3 \times 3) \times 10.2 = 4590 \text{ L}/\text{min}$$

$$R_s = S \times Q = 0.0748 \times 4590 = 343 \text{ m}^3/\text{min}$$
  - (e) Normal foam shrinkage:  $C_N = 1.15$  [from 7.12.8.2.3.3]
  - (f) Leakage:  $C_l = 1.2$  (assumption)
  - (g) Total generator capacity:

[A.7.12.8.2.3.1b]

$$R = \left( \frac{V}{T} + R_s \right) \times C_N \times C_l$$

$$R = \left( \frac{15,628}{5} + 343 \right) \times 1.15 \times 1.2$$

$$R = 4787 \text{ m}^3/\text{min}$$

**A.7.12.8.2.3.2** Where sprinklers are present in an area to be protected by high-expansion foam, simultaneous operation will cause breakdown of the foam. The rate of breakdown will depend on the number of sprinklers operating and the subsequent total rate of water discharge. The number of sprinklers expected to operate will depend on various factors as outlined in NFPA 13.

**A.7.12.8.2.3.4** It is essential that uncontrolled leakage be reduced to an absolute minimum through the use of foamtight barriers at all openings below the effective hazard control level or depth. There will be an increased rate of foam escape as its fluidity is increased by anticipated sprinkler discharge. Such

leakage through drains, trenches, under doors, around windows, and so forth can be minimized by use of suitable automatic closures, seals, or mechanisms. Additional generator capacity should be added to compensate for the aggregate losses where foam escapement cannot be effectively controlled.

**A.7.12.10** The choice of a total flooding foam system for protection of a hazard does not necessarily imply that it is expected that the system will completely extinguish the fire or even so nearly extinguish it as to render the fire incapable of regaining the offensive. Rather, the effect sought might often be speedy control with minimum fire damage to contents not involved in the fire.

When high-expansion foam is establishing or has established control of a fire, care must be exercised that control is not lost. The following points should be kept in mind; depending on the particular fire, some or all might be vital:

- (1) All persons should be aware of the necessity for tight closure. Employees, brigade members, and the fire department should move rapidly to close any openings through which foam is being lost. Improvised closures can be made of practically any available material such as fine mesh screening, plastic, plywood, or cardboard.
- (2) If the material involved is liable to sustain deep-seated fires, such as furniture, packaged material, fibers, and rolls of paper, particular care must be exercised in opening up the areas and removing the foam. Even where only surface fire is thought possible, as in flammable liquids, smoldering Class A material can cause reignition.
- (3) A "soaking" period should elapse before foam is removed. This period can be as long as an hour and should be predetermined based on the fuel in the area.

**A.7.12.10.3.2** Additional foam concentrate could be needed should reignition occur.

**A.7.12.10.4** The following points should be considered during overhaul operations:

- (1) All foam and sprinkler systems that are shut off should have personnel standing by valves to turn them back on if this should become necessary.
- (2) Foam supplies should be replenished if depleted.
- (3) Hand hoselines should be charged and manned. Personal protective equipment should be donned. Self-contained breathing apparatus must be worn in the "ready" position so there will be no delay in putting it in service.
- (4) Foam should be removed first from the fire area and should be coordinated with overhaul and salvage operations. The total loss will be kept to a minimum if thoughtless operations are avoided. Once the fire is under control, undue haste to extinguish the last ember can greatly increase the loss.
- (5) Caution should be taken in entering previously foam-filled areas, particularly in structures with pits or openings in the floor.
- (6) The area should be well ventilated, but openings through which foam might be lost should be kept to a minimum and manned for closing if this should become necessary.
- (7) Consideration should be given to disposal of the foam to prevent any undue hazard to adjacent areas.

**A.7.13.1.2** These systems are best adapted to the protection of essentially flat surfaces such as confined spills, open tanks, drainboards, curbed areas, pits, trenches, and so forth.

**A.7.13.3.2** Fences constructed of ordinary metal window screen mesh have been shown to provide an effective barrier that allows confinement of medium- and high-expansion foam to a protected area.

**A.7.14** High-expansion foam has been shown to be effective in controlling LNG spill test fires and in reducing downwind vapor concentration from unignited LNG spill test fires in confined areas up to 1200 ft<sup>2</sup> (110 m<sup>2</sup>).

Special provisions for liquefied natural gas (LNG) fire and vapor control are as follows:

- (1) *Application concepts for fire control.* Tests sponsored by the American Gas Association (AGA) have shown that the amount of radiation from a burning LNG spill can be reduced by as much as 95 percent with some high-expansion foams. This reduction is due in part to the foam barrier, which reduces vaporization by blocking heat feedback from the flames to the LNG. Foams having a low-expansion ratio contain a great deal of water at ambient temperature that tends to increase the vaporization rate when it drains into the LNG. In the AGA tests, control was established with expansion ratios greater than 250:1, although an expansion ratio of about 500:1 proved most effective. Different brands of foam show considerable variation in their ability to control LNG fires. A rapidly draining foam will increase the LNG vaporization rate and exaggerate the fire intensity. The drier foam remaining is less resistant to thermal effects and breaks down more readily. Other factors such as bubble size, fluidity, and linear burn rate can affect fire control. Therefore, test results on LNG fires, including the test described in Section G.4 should be reviewed before selecting a foam for LNG fire control.
- (2) *Downwind vapor hazard control.* When first evolved from a spill, unignited LNG vapors are heavier than air. As these vapors are heated by sunlight or by contact with the air, they eventually become buoyant and disperse upward. Before this upward dispersal occurs, however, high vapor concentrations can form downwind of an unignited spill at or near ground level. High-expansion foam can be used to reduce this vapor concentration by adding heat from the water in the foam to the LNG vapors as they pass through the foam blanket. Because of the induced buoyancy, the application of high-expansion foam can reduce downwind gas concentrations at ground level. Expansions in the range of 750:1 to 1000:1 have been found to provide the most effective dispersion control, but the higher expansions can be adversely affected by wind. However, as with fire control, ability to control vapor dispersion varies among different foams and should be demonstrated by tests.

See NFPA 59A for information on fire protection requirements for LNG facilities.



**A.7.14.1** LNG fire and vapor control reference publications are as follows:

- (1) American Gas Association Project IS-3-1, "LNG Spills on Land," November 15, 1973.
- (2) American Gas Association Project IS-100-1, "An Experimental Study on the Mitigation of Flammable Vapor Dispersion and Fire Hazards Immediately Following LNG Spills on Land," February 1974.
- (3) Gremeles, A. E., and Drake, E. M., "Gravity Spreading and Atmospheric Dispersion of LNG Vapor Clouds," Fourth International Symposium on Transport of Hazardous Cargoes by Sea and Inland Waterways, Jacksonville, FL, October 1975.
- (4) Humbert-Basset, R., and Montet, A., "Flammable Mixture Penetration in the Atmosphere from Spillage of LNG," Third International Conference on LNG, Washington, DC, September 1972.
- (5) "Liquefied Natural Gas/Characteristics and Burning Behavior," Conch Methane Services, Ltd., 1962.
- (6) "LNG Vapor Concentration Reduction and Fire Control with MSAR High Expansion Foam," Mine Safety Appliances Research Corp., Evans City, PA.
- (7) Schneider, Alan L., "Liquefied Natural Gas Safety Research Overview," National Technical Information Service, Springfield, VA, December 1978.
- (8) Welker, J., et al., "Fire Safety Aboard LNG Vessels," January 1976.
- (9) Wesson, H. R., Welker, J. R., and Brown, L. E., "Control LNG Spill Fires," *Hydrocarbon Processing*, December 1972. This paper contains 105 additional references on many aspects of LNG safety research, including the use of high-expansion foam on LNG.

Since time to initiate actuation is a critical factor in LNG fire control, special attention should be given to heat effects and potential fire spread to adjacent areas during the time period for application of foam into the LNG spill.

**A.7.14.2** Application rates are generally established by specific fire tests such as that in Section G.4, where the equipment, water supply, fuel, and physical and chemical makeup of the candidate foam concentrate are carefully controlled. While these tests can be useful for comparing various foams, they often give minimum application rates because they are conducted under ideal weather conditions with no obstructions or barriers to fire control. The final design rates are generally 3 to 5 times the test rates. Thus, the rates can vary significantly from one foam agent to another.

**A.7.14.3.3** The minimum foam depth at any point in the hazard area will vary, but most designs have attempted to obtain 18 in. to 36 in. (450 mm to 900 mm) of foam depth over the LNG spill area within the time established in the analysis.

**A.7.15.6** Successful extinguishment of fire with portable foam-generating devices is dependent on the individual ability and technique of the operator.

**A.9.1** It is good practice for the owner or his or her designated representative (i.e., architect, contractor, or other authorized person) to review the basic hazard or modifications with the AHJ to obtain guidance and preliminary approval of the proposed protection concept. The possibility and extent of damage by the agent should be evaluated when selecting any extinguishing system. In certain cases, such as tanks or containers of edible oils, cooking oils, or other food-processing agents,

or in other cases where contamination through the use of foam could increase the loss potential substantially, the AHJ should be consulted regarding the type of extinguishing agent preferred.

**A.9.2.3** The cost of testing beyond the requirements of this standard, but requested by the AHJ, should be considered. The specification should indicate how testing costs are to be met.

**A.9.3.3(27)** See Chapter 23 of NFPA 13 for hydraulic calculation procedures.

**A.9.3.7.2(10)** Actual discharge conditions are based on the supply calculations (i.e., balanced to the available supply calculations, per 6.5.10.2.2).

**A.10.3.4** Limited service controllers generally do not have a service disconnect means. In order to perform routine inspection and maintenance safely, it might be desirable to provide an external service disconnect. Special care must be taken to ensure that the disconnect is not left in a position rendering the foam concentrate pump inoperable.

**A.10.4.2** One of the following designs can be used:

- (1) Piping less than 4 in. (100 mm) in diameter
  - (a) Where piping is buried, a swing joint or other means should be provided at each tank riser to absorb the upward force. The swing joint should consist of approved standard weight steel, ductile, or malleable iron fittings.
  - (b) Where piping is supported aboveground, it should not be secured for a distance of 50 ft (15 m) from the tank shell to provide flexibility in an upward direction so that a swing joint is not needed. If there are threaded connections within this distance, they should be back welded for strength.
- (2) The vertical piping of 4 in. (100 mm) in diameter and greater on the protected tank should be provided with one brace at each shell course. This design should be permitted to be used in lieu of swing joints or other approved aboveground flexibility, as specified in A.10.4.2(1)(a) and A.10.4.2(1)(b). This riser can be welded to the tank by means of steel brace plates positioned perpendicular to the tank and centered on the riser pipe.

**A.10.4.3** With all-welded construction, this could be the only joint that can be opened.

**A.10.5.7** Failure to isolate the water supply feed to the bladder tank can cause a continuation of foam concentrate discharge into the system riser. This continued discharge can cause damage to the bladder and siphon tube inside the tank and can waste foam concentrate. Risers that have filled with foam concentrate due to this issue can be inadvertently drained, thus contaminating the environment with foam concentrate.

**A.11.1** The provisions of this marine chapter were developed based on knowledge of practices of this standard, SOLAS, the IBC Code, and USCG regulations and guidance. In order to harmonize the requirements of this chapter with the practices of these other standards, the values given in the metric conversions in Chapter 12 should be considered the required value.

**A.11.1.3** Approvals of specialized foam equipment components are typically based on compliance with a standard equivalent

lent to UL 162. Component review should include the following:

- (1) Fire suppression effectiveness
- (2) Reliability
- (3) Mechanical strength
- (4) Corrosion resistance
- (5) Material compatibility
- (6) Proper operation
- (7) Stress, shock, and impact
- (8) Exposure to salt water, sunlight, temperature extremes, and other environmental elements
- (9) Proportioning system test data (demonstrating acceptable injection rate over the intended flow range of the system)
- (10) Foam stream range data (based on still air testing with monitor and nozzle combinations)
- (11) Foam quality test data (demonstrating satisfactory performance corresponding to small-scale fire test nozzle foam quality)

Quality control of specialty foam proportioning and application equipment as well as foam concentrates should be achieved through a listing program that includes a manufacturing follow-up service, independent certification of the production process to ISO 9001, or a similar quality control program approved by the AHJ.

**A.11.1.4.3** Foams for polar solvents are first tested for hydrocarbon performance using a test derived from Federal Specification O-F-555C that was published from 1969 through 1990. The foams are further tested for polar solvent system application on the basis of 50 ft<sup>2</sup> (4.6 m<sup>2</sup>) fire test performance in accordance with UL 162. Approved manufacturers' deck system design application rates and operating times incorporate design factors that are applied to the fire test application rates and times.

**A.11.2.1** This system is intended to supplement, not replace, any required total flooding machinery space fire suppression system. Foam systems comprising a portion of required primary machinery space protection can require longer application times.

**A.11.3.1** Although shipboard foam systems share many similarities with tank farm foam systems on land, there are important differences between shipboard and land-based fire protection. These differences, identified in (1) through (15), result in foam system designs and arrangements that differ from systems used in what can appear to be similar land-based hazards. The differences are as follow:

- (1) Foam fire tests of the type described in Annex F are very severe.
- (2) There is limited data regarding use of systems meeting USCG or IMO requirements on actual fires.
- (3) There is little or no separation between tanks.
- (4) The vessel might be widely separated from other hazards or might be alongside another vessel or a terminal.
- (5) The vessel might not have access to immediate firefighting assistance.
- (6) Fires resulting from catastrophic events, such as explosions and collisions, historically are beyond the onboard firefighting capabilities of the involved vessels, necessitating use of outside firefighting assistance. Many large fires have taken several days to extinguish.

- (7) The number of firefighting personnel is limited to the available crew.
- (8) Fires not substantially controlled within the first 20 minutes can exceed the capability of the crew and the onboard system.
- (9) Ships are subject to rolling, pitching, and yawing, which can cause sloshing of the burning liquid and reduced performance of the foam blanket.
- (10) Application of foam to the fire is likely to be much faster than on land because the deck foam system is in place and can be activated simply by starting a pump and opening certain valves. There is little or no setup time.
- (11) Tank fires do not seem to occur unless preceded by an explosion.
- (12) Explosions can cause substantial damage to foam systems. They can have unpredictable results on the vessel structure, including bending deck plating in such a way as to obstruct foam application. They can also cause involvement of any number of tanks or spaces.
- (13) Most tankers use inert gas systems to reduce vapor spaces above cargo tanks to less than 8 percent oxygen, thereby reducing the likelihood of an explosion.
- (14) Ships pay the cost of transporting their fire suppression systems on every voyage.
- (15) There is a finite amount of space on each ship design. Tanker deck foam monitors are located at or above the elevation of top of the tank as contrasted with typical tank farm arrangements where monitors must project foam up and over the rim of a tank.

**A.11.3.2.2** Color coding the valves aids in identification. For example, all valves that are to be opened might be painted some distinctive color.

**A.11.3.3** A fire main system can provide other services in addition to fire protection. Other services, which could be left operational during a fire, need to be included in calculations.

**A.11.3.4** Rates of application are as follows:

- (1) Differences between this section and SOLAS or the IBC Code: The application rates prescribed in this section for hydrocarbon fuels are higher than the rates given in the International Maritime Organization's International Convention for the Safety of Life at Sea (SOLAS) Chapter 212, Regulation 61, as follows:
  - (a) For deck spills, this section requires 0.16 gpm/ft<sup>2</sup> (6.5 mm/min) applied over the 10 percent of the cargo block versus 0.147 gpm/ft<sup>2</sup> (5.98 mm/min) in SOLAS. This difference is based on a long history of fire extinguishment experience using 0.16 gpm/ft<sup>2</sup> (6.5 mm/min). It is also understood that the value 0.16 gpm/ft<sup>2</sup> (6.5 mm/min) is generally regarded as the minimum foam application rate for industrial hazards and reflects the minimum application rate on the fuel surface, not at the discharge device. Thus, loss of foam due to wind, obstructions, and so forth, should be compensated for to provide 0.16 gpm/ft<sup>2</sup> (6.5 mm/min) on the liquid surface.
  - (b) For the single largest tank, this section requires 0.24 gpm/ft<sup>2</sup> (9.77 mm/min) over the single largest hydrocarbon tank versus 0.147 gpm/ft<sup>2</sup> (5.98 mm/min) in SOLAS. This difference is based on the need to deliver a minimum of 0.16 gpm/ft<sup>2</sup> (6.5 mm/min) onto the surface of the burning fuel and takes into consideration the impact of wind,

evaporation, and thermal updrafts. This value is consistent with recent experience with the extinguishment of shore-based storage tanks using mobile foam equipment similar to the monitors used in deck foam systems.

- (c) For polar solvents, the *International Bulk Chemical Code (IBC Code)* provides two design methods. The first method requires a foam application rate of 0.5 gpm/ft<sup>2</sup> (20.3 mm/min) without restriction to the type of chemicals that can be carried or where on the ship's cargo block they can be carried. The second method allows arrangements with application rates lower than 0.5 gpm/ft<sup>2</sup> (20.3 mm/min). This method is allowed if the country where the vessel is registered has determined through fire tests that the actual foam application rate at each cargo tank is adequate for the chemicals carried in that tank. The design practices given in this section comply with the second method of the *IBC Code*.
- (2) For reliance on monitor application, it is recognized that for land applications this standard generally restricts monitor application of foam according to tank diameter and surface area. A significant difference between monitor applications on land and those on tank ships is that the monitors on tank ships are located at or above the elevation of the top of the tank. Therefore, shipboard systems do not suffer losses of agent associated with long throws getting foam up and over tank rims. Additionally, tank ship monitors can be placed in operation immediately after an incident, as there is little or no setup time and each monitor is required to be sized to deliver at least 50 percent of the required foam application rate.
- (3) The application rates given in this section incorporate design factors that allow the results of small-scale fire tests to be applied to full-scale fires. Design factors include scaling factors that allow the results of small-scale tests to be extrapolated to large scale. In addition, compensation factors are included to account for losses expected from wind, thermal updraft, stream break-up, plunging, and

other adverse conditions. The application rates and incorporated design factors are shown in Table A.11.3.4.

- (4) The design philosophy given in this standard reflects that outlined in NVIC 11-82. NVIC 11-82 assumes that the minimum single tank design application rate will be 0.16 gpm/ft<sup>2</sup> (6.5 mm/min). It then allows monitors to be calculated using 45 percent of the single tank rate. SOLAS and the IBC Code require the monitor to be calculated at 50 percent of the single tank rate. However, SOLAS starts with a single tank application rate of 0.147 gpm/ft<sup>2</sup> (6 mm/min) so that 50 percent of that rate exactly equals 0.0735 gpm/ft<sup>2</sup> (3 mm/min), which is 45 percent of the NVIC 11-82 minimum application rate of 0.16 gpm/ft<sup>2</sup> (6.5 mm/min). The IBC Code also requires monitors to be sized for 50 percent of the single tank flow rate.

**A.11.3.5.1** Foam application durations given in this section are generally lower than those given in other sections of this standard. This difference is based on historically quick deployment of marine deck foam systems and also takes into account all of the factors listed in A.11.3.1.

**A.11.3.5.4** The flow rates during an actual system discharge will generally be greater than the minimum rates calculated during system design because pumps, eductors, and nozzles are typically not available in sizes for the exact minimum flow rate needed. Therefore, this equipment will typically be selected at the next larger commercially available size. Because the system, built of components larger than the minimum required, will flow foam at a rate greater than the minimum calculated, the foam concentrate will be used faster than the minimum usage rate. Since the concentrate will be used at a rate higher than the minimum, the storage quantity should be sized to provide the actual delivery rate during the entire required discharge duration.

**A.11.4** Although foam handlines are required for supplementary protection, it is not practical to rely on handlines for primary firefighting. Therefore, all required foam application must be provided by monitors that cover the protected area.

**Table A.11.3.4 Foam Application Rates**

Fuel	Scenario	100 ft <sup>2</sup> Test Fire	Scaling Design Factor	Fuel Surface Application Rate	Compensation Design Factor	Required Application Rate
Hydrocarbon	Deck spill	0.06 gpm/ft <sup>2</sup> (2.4 mm/min)	2.67 (8/3)	0.16 gpm/ft <sup>2</sup> (6.5 mm/min)	1.0	0.16 gpm/ft <sup>2</sup> (6.5 mm/min)
Hydrocarbon	Single largest tank	0.06 gpm/ft <sup>2</sup> (2.4 mm/min)	2.67	0.16 gpm/ft <sup>2</sup> (6.5 mm/min)	1.5	0.24 gpm/ft <sup>2</sup> (9.8 mm/min <sup>2</sup> )
Polar	Deck spill	Rate ≥ 0.06 gpm/ft <sup>2</sup> (2.4 mm/min) as determined by test	2.67	Test rate × 2.67 ≥ 0.16 gpm/ft <sup>2</sup> (6.5 mm/min)	1.0	≥ 0.16 gpm/ft <sup>2</sup> (6.5 mm/min)
Polar	Single largest tank	Rate ≥ 0.06 gpm/ft <sup>2</sup> (2.4 mm/min) as determined by test	2.67	Test rate × 2.67 ≥ 0.16 gpm/ft <sup>2</sup> (6.5 mm/min)	1.5	≥ 0.24 gpm/ft <sup>2</sup> (9.8 mm/min <sup>2</sup> )

Note: L/min-m<sup>2</sup> is equivalent to mm/min.

**A.11.9.2** Pipe should be uniformly supported to prevent movement due to gravity, heaving of the vessel in heavy weather, impact, and water hammer. Pipe should be supported by steel members.

**A.11.9.3** Deck foam system piping is not a substitute for any portion of a vessel's fire main system. Conversely, the requirement is intended to clarify that foam injected into the ship's fire main is not a substitute for a dedicated foam system on the weather deck. The requirement is not intended to prevent the proportioning of foam into a ship's fire main. Such a capability may be of great value during a machinery space fire or any other fire involving flammable liquids.

**A.11.9.5** The system should be arranged to prevent ice from forming in any portion of the system. Sloped piping and manual low point drains are considered to meet the requirement that the system be self-draining.

**A.11.10.1** Refer to the environmental report (*Annex E*) for further information related to environmental issues when system discharge tests are performed.

**A.11.11.1.1** The primary foam concentrate tank is the tank containing the supply calculated to satisfy the requirements of 11.3.4 and 11.3.5. The location of emergency back-up supplies and supplies of concentrate for refilling the primary tank are not subject to the storage location restrictions of 11.11.2. However, all foam concentrate storage is subject to other provisions of this chapter such as those regarding prevention of freezing and foam compatibility.

**A.11.11.2.1** Corrosion occurs at the air/foam/tank interface. Therefore, the small surface area of this interface in the tank dome results in less corrosion than if the interface occurs in the body of the tank. Tank domes are also used to reduce the available free surface subject to sloshing. Sloshing causes premature foaming and adversely affects foam proportioning. In addition, sloshing can cause cracking or other damage to the tank. Foam also evaporates, so the use of a pressure vacuum (PV) vent is necessary. A PV vent allows air to enter the tank as liquid is discharged, allows air to leave the tank as liquid fills the tank, and allows the PV valve to prevent evaporation of the concentrate.

**A.11.12.1** Examples of acceptable arrangements are shown in Figure A.3.3.26.1 and Figure A.3.3.26.1.1(a). Consideration should be given to the need for spare or redundant critical equipment.

**A.11.12.3** Where foam concentrate pumps are flushed with sea water, the pump should be constructed of materials suitable for use with sea water.

**A.11.12.4** Portions of TP 127 E are generally considered equivalent to IEEE 45.

**A.11.13.5** Some pipe joint sealants are soluble in foam concentrate.

**A.12.3** Acceptance tests should encompass the following:

(1) A foam system will extinguish a flammable liquid fire if operated within the proper ranges of solution pressure and concentration and at sufficient discharge density per square foot (square meter) of protected surface. The acceptance test of a foam system should ascertain the following:

- (a) All foam-producing devices are operating at system design pressure and at system design foam solution concentration.
  - (b) Laboratory-type tests have been conducted, where necessary, to determine that water quality and foam liquid are compatible.
- (2) The following data are considered essential to the evaluation of foam system performance:
- (a) Static water pressure
  - (b) Stabilized flowing water pressure at both the control valve and a remote reference point in the system
  - (c) Rate of consumption of foam concentrate

The concentration of foam solution should be determined. The rate of solution discharge can be computed from hydraulic calculations utilizing recorded inlet or end-of-system operating pressure or both. The foam liquid concentrate consumption rate can be calculated by timing a given displacement from the storage tank or by refractometric or conductivity means. The calculated concentration and the foam solution pressure should be within the operating limit recommended by the manufacturer.

**A.12.6** The rate of concentrate consumption can be measured by timing a given displacement from the foam concentrate storage tank, but only in systems where the storage tank is small enough and the test run time is long enough so that this can be accomplished with reasonable accuracy.

**A.12.6.2(1)** Instruments should have automatic temperature compensation.

**A.12.6.2(2)** Digital electric conductivity can be accomplished by handheld or online computer data acquisition devices. Instruments should have automatic temperature compensation.

**A.12.6.3** Recording the expansion ratio and drain time of SFFF and comparing them to the manufacturer's listing report or manufacturer's specifications can help to ensure system performance. See Annex H.

**A.12.6.4** FM Approvals 5138 should be consulted for possible listing requirements.

**A.12.7(3)** A sample material and test certificate is provided in Figure A.12.7(3).

**A.12.9.1** Underground mains and lead-in connections to system risers should be flushed through hydrants at dead ends of the system or through accessible aboveground flushing outlets, allowing the water to run until clear. If water is supplied from more than one source or from a looped system, divisional valves should be closed to produce a high-velocity flow through each single line.

It is recommended that foam concentrate lines be tested using foam concentrate as the testing medium.

**A.12.9.2.1** To prevent the possibility of serious water damage in case of a break, pressure should be maintained during the 2-hour test period by a small-capacity pump, with the main controlling gate closed tightly during this period.

Contractor's Material and Test Certificate for Low-Expansion Foam												
<b>PROCEDURE</b>												
Upon completion of work, inspection and tests shall be made by the contractor's representative and witnessed by an owner's representative. All defects shall be corrected and system left in service before contractor's personnel finally leave the job.												
A certificate shall be filled out and signed by both representatives. Copies shall be prepared for approving authorities, owners, and contractor. It is understood the owner's representative's signature in no way prejudices any claim against contractor for faulty material, poor workmanship, or failure to comply with approving authority's requirements or local ordinances.												
Property name						Date						
Property address												
<b>Plans</b>	Accepted by approving authorities (names)											
	1 _____											
	2 _____											
	3 _____											
<b>Plans</b>	Address											
	1 _____											
	2 _____											
	3 _____											
Installation conforms to accepted plans								<input type="checkbox"/> Yes	<input type="checkbox"/> No			
Equipment used is approved								<input type="checkbox"/> Yes	<input type="checkbox"/> No			
If no, explain deviations												
<b>Instructions</b>	Has person in charge of fire equipment been instructed as to location of control valves and care and maintenance of this new equipment?								<input type="checkbox"/> Yes	<input type="checkbox"/> No		
	If no, explain											
	Have copies of the following been left on premises?											
	1. System components instructions								<input type="checkbox"/> Yes	<input type="checkbox"/> No		
2. Care and maintenance instructions								<input type="checkbox"/> Yes	<input type="checkbox"/> No			
3. NFPA 25								<input type="checkbox"/> Yes	<input type="checkbox"/> No			
4. With whom have the copies been left? _____												
<b>Location of system</b>	Supplies buildings					Square footage						
	_____					_____						
	_____					Total square footage						
<b>Discharge devices</b>	Make		Model		Year of manufacture		Orifice size	Quantity		Other		
	_____		_____		_____		_____	_____		_____		
<b>Pipe and fittings</b>	Type of pipe _____											
	Type of fittings _____											
<b>Alarm valve or flow indicator</b>	Alarm device					Maximum time to operate through test connection						
	Type		Make		Size	Model		Min.		Sec.		
	_____		_____		_____	_____		_____		_____		
<b>Dry pipe operating test</b>	Dry valve				Q. O. D.							
	Make	Size	Model	Serial no.	Type		Make	Size	Model	Serial no.		
	_____	_____	_____	_____	<input type="checkbox"/> Accelerator		_____	_____	_____	_____		
	Time to trip thru test connection		Water pressure		Air pressure		Trip point air pressure		Time water reached test outlet*		Alarm operated properly	
		Min.	Sec.	PSI	PSI	PSI	Min.	Sec.	Yes	No		
	Without Q. O. D.	_____	_____	_____	_____	_____	_____	_____	_____	_____		
With Q. O. D.	_____	_____	_____	_____	_____	_____	_____	_____	_____			
If no, explain												
*Measured from time inspector's test connection is opened.												
© 2020 National Fire Protection Association												
NFPA 11 (p. 1 of 3)												

FIGURE A.12.7(3) Sample Material and Test Certificate.

<b>Deluge &amp; preaction valves</b>	Operation <input type="checkbox"/> Pneumatic <input type="checkbox"/> Electric <input type="checkbox"/> Hydraulic																				
	Piping supervised? <input type="checkbox"/> Yes <input type="checkbox"/> No				Detecting media supervised? <input type="checkbox"/> Yes <input type="checkbox"/> No																
	Does valve operate from the manual trip, remote, or both control stations? <input type="checkbox"/> Yes <input type="checkbox"/> No																				
	Is there an accessible facility in each circuit for testing? If no, explain: <input type="checkbox"/> Yes <input type="checkbox"/> No																				
			Model		Does each circuit operate supervision loss alarm?		Does each circuit operate valve release?		Maximum time to operate release												
				Yes No		Yes No		Min. Sec.													
<b>Pressure-reducing valve test</b>	Location and floor		Make and model		Setting		Static pressure		Residual pressure (flowing)		Flow rate										
							Inlet (psi) Outlet (psi)		Inlet (psi) Outlet (psi)		Flow (gpm)										
<b>Backflow preventers</b>	Make			Model			Size														
<b>Foam</b>	High flow rate _____ gpm @ _____ psi Results fall within -0% to +30% for balanced pressure system: <input type="checkbox"/> Yes <input type="checkbox"/> No																				
	Low flow rate _____ gpm @ _____ psi Results fall within -0% to +30% for balanced pressure system: <input type="checkbox"/> Yes <input type="checkbox"/> No																				
<b>Test description</b>	For positive pressure systems with pump or pressure controlled bladder tank and in-line balanced pressure type proportioning systems: -0% to +30% or greater: <input type="checkbox"/> Yes <input type="checkbox"/> No																				
	Foam concentrate induction rate -0% to +30% of manufacturers listed induction rate or 1 percentage point, whichever is less at listed flow rates: <input type="checkbox"/> Yes <input type="checkbox"/> No																				
	Balanced pressure proportioning systems produce the minimum percentage of manufacturers requirements -0% at minimum listed flow rate: <input type="checkbox"/> Yes <input type="checkbox"/> No																				
	Positive pressure proportioning with pumps or pressure-controlled bladder tanks produce the maximum percentage of manufacturers requirement +30% or 1 percentage point, whichever is less at the minimum listed flow rate: <input type="checkbox"/> Yes <input type="checkbox"/> No																				
	Variable pressure orifice type proportioners produce the percentage -0% to +30% or 1 percentage point, whichever is less: <input type="checkbox"/> Yes <input type="checkbox"/> No																				
	Foam discharge was collected and disposed of properly: <input type="checkbox"/> Yes <input type="checkbox"/> No																				
<b>Tests</b>	Approved simulated foam concentrates were used for this test: <input type="checkbox"/> Yes <input type="checkbox"/> No																				
	Type _____																				
	All foam residue was removed from the piping system by flushing with clean water <input type="checkbox"/> Yes <input type="checkbox"/> No																				
	<b>Hydrostatic:</b> Hydrostatic tests shall be made at not less than 200 psi (13.6 bar) for 2 hours or 50 psi (3.4 bar) above static pressure in excess of 150 psi (10.2 bar) for 2 hours. Differential dry-pipe valve clappers shall be left open during the test to prevent damage. All aboveground piping leakage shall be stopped. Maximum static pressure: _____																				
	<b>Pneumatic:</b> Establish 40 psi (2.7 bar) air pressure and measure drop, which shall not exceed 1 1/2 psi (0.1 bar) in 24 hours. Test pressure tanks at normal water level and air pressure and measure air pressure drop, which shall not exceed 1 1/2 psi (0.1 bar) in 24 hours.																				
<b>Tests</b>	All piping hydrostatically tested at _____ psi (_____ bar) for _____ hrs. If no, state reason																				
	Dry piping pneumatically tested <input type="checkbox"/> Yes <input type="checkbox"/> No																				
	Equipment operates properly <input type="checkbox"/> Yes <input type="checkbox"/> No																				
	Do you as the sprinkler contractor certify that additives and corrosive chemicals, sodium silicate or derivatives of sodium silicate, brine, or other corrosive chemicals were not used for testing systems or stopping leaks? <input type="checkbox"/> Yes <input type="checkbox"/> No																				
	<table border="1"> <tr> <td>Drain test</td> <td colspan="5">Reading of gauge located near water supply test connection: _____ psi (_____ bar)</td> <td colspan="5">Residual pressure with valve in test pipe open wide _____ psi (_____ bar)</td> </tr> </table>											Drain test	Reading of gauge located near water supply test connection: _____ psi (_____ bar)					Residual pressure with valve in test pipe open wide _____ psi (_____ bar)			
Drain test	Reading of gauge located near water supply test connection: _____ psi (_____ bar)					Residual pressure with valve in test pipe open wide _____ psi (_____ bar)															
Underground mains and lead-in connections to system risers flushed before connection made to sprinkler piping. Verified by copy of the U Form No. 85B <input type="checkbox"/> Yes <input type="checkbox"/> No Other Explain																					
Flushed by installer of underground sprinkler piping <input type="checkbox"/> Yes <input type="checkbox"/> No																					
If powder-driven fasteners are used in concrete, has representative sample testing been satisfactorily completed? <input type="checkbox"/> Yes <input type="checkbox"/> No																					
If no, explain																					

FIGURE A.12.7(3) Continued

Blank testing gaskets	Number used	Locations	Number removed
	Welded piping <input type="checkbox"/> Yes <input type="checkbox"/> No		
	If yes . . . .		
	Do you certify as the sprinkler contractor that welding procedures comply with the requirements of at least AWS B2.1?		<input type="checkbox"/> Yes <input type="checkbox"/> No
	Do you certify that the welding was performed by welders qualified in compliance with the requirements of at least AWS B2.1/B2.1M?		<input type="checkbox"/> Yes <input type="checkbox"/> No
	Do you certify that welding was carried out in compliance with a documented quality control procedure to ensure that all discs are retrieved, that openings in piping are smooth, that slag and other welding residue are removed, and that the internal diameters of piping are not penetrated?		<input type="checkbox"/> Yes <input type="checkbox"/> No
Cutouts (discs)	Do you certify that you have a control feature to ensure that all cutouts (discs) are retrieved?		<input type="checkbox"/> Yes <input type="checkbox"/> No
Hydraulic data nameplate	Nameplate provided <input type="checkbox"/> Yes <input type="checkbox"/> No If no, explain		
Remarks	Date left in service with all control valves open:		
Signatures	Name of sprinkler contractor _____		
	Address _____		
	Phone _____		
	Fax _____		
	Tests witnessed by		
	For property owner (signed)	Title	Date
	For sprinkler contractor (signed)	Title	Date
Additional explanation and notes			
© 2020 National Fire Protection Association			
NFPA 11 (p. 3 of 3)			

FIGURE A.12.7(3) *Continued*

**A.12.9.3.1** The following are acceptance test recommendations:

- (1) All tests should be made by the contractor in the presence of the inspector for the AHJ.
- (2) Before asking for final approval of the protective equipment by the AHJ, installation companies should furnish a written statement to the effect that the work covered by its contract has been completed and all specified flushing of underground, lead-in, and system piping has been successfully completed, together with specified hydrostatic pressure tests and system foam discharge tests.
- (3) The samples of the contractor's material and test certificates for aboveground and underground piping that appear in Chapter 16 of NFPA 13 can be useful to the contractor as a guide in filing written statements as described in A.12.9.3.1 (2).
- (4) Where full flow tests with foam cannot be performed for foam-water deluge systems, a full flow discharge test with water only and a test of component function to verify design capability should be considered. Where full discharge tests with water cannot be performed, a test of component function to verify design capability should be performed.
- (5) Foams produced from foam-water discharge outlets are generally of lower expansion and faster drainage than

foams from other foam-producing devices. Laboratory listing and test data demonstrate that satisfactory fire control and extinguishment of petroleum fuels can be achieved using foam-water sprinklers producing foam characteristics as in Table A.12.9.3.1.

Numerical values developed by use of the test methods referenced in Table A.12.9.3.1 are not directly comparable, so care should be taken to use the proper test method. In general, AFFF drains much more rapidly than protein and fluoroprotein foams, necessitating use of the alternate method.

**A.12.9.4** NFPA 11 is a standard for installation of foam-water fixed spray and sprinkler systems used as deluge open discharge devices (fixed nozzles or sprinklers) and closed systems utilizing heat-activated fusible sprinklers applied in wet pipe, dry pipe, or preaction-type systems. This standard includes the use of low-expansion foams such as aqueous film forming foam (AFFF) for hydrocarbon fuel, alcohol or water-miscible fuels using foams that are AFFF/ARC, and film forming fluoroprotein (FFFP) foams for use on hydrocarbon fuels. Foam concentrates are proportioned into the supply to the discharge system using several different methods of proportioning systems, depending on the type of application and the type of foam concentrate being applied. Also, different manufacturers include several different methods of proportioning their

Table A.12.9.3.1 Foam Expansion Drainage Time

Type of Foam	Expansion	25 Percent Drainage Time, Minimum (sec)
Protein foam and fluoroprotein foam	3:1 to 8:1	15
Aqueous film-forming foam	3:1 to 8:1	60

Note: Test data apply to foam characteristics determined by the method specified in Annex D of NFPA 11.

foam concentrates based on performance of the proportioning equipment and combination of use with different foam concentrates and equipment size restraints. Past full-scale fire testing has shown that when applying foam-water solution of AFFF or AFFF/ARC foams through sprinklers or fixed spray nozzles, reduced application density and/or higher storage or quicker extinguishment is possible. Also, the systems allow for continued flow of water to be used for cooling after extinguishment of flammable or combustible fuel fires. If the installed proportioning equipment is insufficient to provide the proper foam-water mixture to the discharge system across the critical flow range of the system in a fire situation, then the system will fail to control the fire. The type of proportioning equipment is very critical to each application due to the type of discharge system, open sprinklers, and/or nozzles in deluge systems having a fixed discharge flow to system and closed sprinklers such as used in wet pipe, dry pipe, and preaction systems that include variable flow rate from initial fire to maximum design capacity of system. The type of foam concentrate also plays an important role in the system performance where AFFF and FFFP foams have a low viscosity close to water and AFFF/ARC foams, which have a very high viscosity close to molasses.

Proportioning systems provided by many manufacturers that are applied in accordance with this standard require that they must be listed with a third party laboratory agency with all the foam concentrates with which they are desired to be applied. The UL 162 foam standard, *Standard for Safety for Foam Equipment and Liquid Concentrates*, is utilized in most cases for this listing, of which all proportioning devices are tested under full-scale flow conditions to determine the minimum and maximum flow rate of each device and all sizes at which the proportioning percentage of the foam concentrate meets the allowed variance of plus 30 percent or 1 percentage point, whichever is smallest, above the manufacturer's specified percentage of foam-to-water mixture and minus 0 for minimum percentage of foam-water mixture. In addition, all foam concentrates must be flow tested for proportioning performance in one configuration size at the minimum allowed storage temperature to verify that the foam can be proportioned to within 85 percent or greater than at ambient temperature. This testing provides the mechanics of each type of system to determine the performance at minimum and maximum flow ranges of the equipment with each type of foam concentrate. Also, this testing can determine the performance that is critical for the type of system and the type of foam concentrate being applied.

The listed types of proportioning systems available include the following:

- (1) Vacuum induction, where a venturi device, called an inductor, decreases the pressure in the foam concentrate proportioning inlet tube to the system flow passageway to system, requires a fixed discharge flow that matches the

flow capacity of the inductor device. The supply pressure and backpressure of the discharge side of the system are very critical for proper operation of this type of system. This system is limited to deluge systems, and the friction loss of the discharge system to the discharge devices must be considered for proper performance. Proportioning percentage can vary based on the discharge and supply characteristics as well as the foam concentrate. These systems require full system discharge flow testing to determine proper installation and sizing.

- (2) Foam concentrate pump discharging foam through a metering orifice directly into the discharge system through a metering orifice specifically sized for the system performance that is being installed. The foam pump discharge pressure must be higher than the system discharge pressure at a predetermined value. This type of system is limited to deluge-type systems and must be flow tested at the desired maximum flow rate of the system. Each installation must be full system flow tested due to specific design parameters for a particular installation.
- (3) Balanced pressure proportioning using foam pump or bladder tank. This type of system uses a modified venturi proportioning device in the system water supply pipe. The water flow to the system through the modified venturi causes a metered pressure drop in the foam concentrate inlet chamber. As the flow increases, the metered pressure loss increases, causing increased flow of foam concentrate through a calibrated orifice into the system water supply. With a foam pump system a balancing valve is used to measure the supply pressure at the inlet of the modified venturi proportioner and balance the foam concentrate pressure down to equal that pressure. This is accomplished by causing the foam concentrate to bypass through the balancing valve back to the foam atmospheric storage tank and by keeping the foam concentrate supply at the same inlet pressure as the water supply. When using a bladder tank the foam concentrate is stored inside a bladder within a pressure vessel where the supply water in the system supply is directed to the outside of the bladder, causing the foam concentrate to push out from the top or bottom of the tank and travel to the inlet of the modified venturi device. As the water pressure increases or decreases due to flow conditions, so does the foam concentrate pressure. In both the balanced pump system and the bladder tank system, when the inlet pressures of both foam concentrate and water supply match the inlet calibrated orifice of the modified venturi device, the proper mixture of foam to water as specified by the manufacturer is provided. All manufacturers publish a minimum and maximum flow for each size device for each foam concentrate listed with each device. When the minimum flows for these systems are given, the percentage of foam concentrate to water is at the mini-



imum. For flow rates less than those published as minimum the foam-to-water percentage is less than the specified percentage. Also, the maximum flow is established at the maximum flow allowed for the system using the specified device and size. For these types of systems AFFF and FFFP foams will generally have a low flow rate per given size of supply device, compared to ARC foams that will have as high a flow rate as the minimum flow for the same given size as AFFF devices. The minimum flow of the most remote (4) sprinklers must be considered as the minimum flow rate of the system when using closed-type sprinkler systems. This is a common result of many full-scale fire tests. The riser size will need to be determined for supply of the proper foam percentage, or a different proportioning system should be used. These types of systems should be flow tested at the minimum listed flows as given by the manufacturer. For both deluge and closed systems, if the percentage of foam to water is at the desired percentage at the minimum flow rate as listed, this demonstrates that the equipment has been properly installed. A mid-range flow might also be desired to indicate a higher percentage of foam mixture at the higher flow rate to indicate proper design. Also, these systems allow for system isolation test valves to be applied and divert test foam solution flow to a containment area that can be easily disposed of.

- (4) Positive-pressure proportioning using foam pump or pressure-controlled bladder tank system uses a system that supplies foam concentrate to a modified venturi at a higher pressure than the supply water pressure. The modified venturi includes a calibrated orifice that is sized to match the system equipment and the foam concentrate being used. These systems also include a balancing valve that senses the water supply pressure and balances the foam supply pressure down to equal the supply water pressure at all flow points. These systems are usually designed to supply the foam concentrate pressure at 15 to 30 psi (1 bar to 2 bar) higher than the water supply pressure to the system. This type of system also is specified with minimum and maximum flow rates for each proportioner size and foam concentrate type. At the listed minimum flow rates of these types of systems the foam percentage is at the maximum listed percentage, and for flows less than the minimum listed the foam concentrate ratio to water percentage increases. This provides rich foam at low flow rates for (4) sprinklers or fewer flows, which is desirable for closed sprinkler systems and where multiple riser systems and variable pressure might exist. Also, where ARC-type foam concentrates are applied this type of system is required for closed sprinkler systems or the system must be broken up into smaller riser sizes using smaller proportioners that meet the required (4) sprinklers flow requirements. These systems provide the best flexibility for multiple risers, variable pressures, and ARC closed sprinklers systems. Proportioner systems testing for these types of systems should include the minimum flow of the system using as a minimum (4) sprinklers nozzle flow rate to see if the foam concentrate proportioning is at least equal to the percentage specified plus 30 percent if at the minimum listed flow or if less than the minimum listed flow the percentage should be greater than the specified maximum percentage. In addition to the minimum flow rate, a test should be performed at a flow rate just above the minimum listed flow rate to determine that the proportioner will perform

within its desired limits. These types of systems can also have and are recommended to have a system isolation valve and discharge test connection to perform flow testing and to direct foam solution to a containment area that can use a controlled disposal method.

Foam-water sprinkler systems have been applied for many years and have been shown to provide control and extinguishment capabilities of highly hazardous flammable and combustible liquids both in process and in storage. In order to guarantee that the system is designed and installed properly for the application for which it was intended, it is imperative that verification is made that the foam being discharged meets the intent of the system and the listed performance of the product. Most of these systems are installed at the job site, and in order to make sure all correct equipment and proper foam concentrate for the protection has been installed properly and in the correct arrangement the systems require at a minimum the performance test that indicates performance as specified under the listings of the products. Also, this makes sure all components are installed in their proper orientation and pressure settings. It is desired to note performance of installation at new commissioning of the installation and then compare in future testing done annually to flag any potential equipment problems.

In these types of systems, if the foam proportioning is inadequate as listed with each product, then the result is equal to shutting off the supply water of a sprinkler system.

In recent years stewardship of disposal is required for AFFF foam solution in non-fire situations as well as in large fire situations to protect from contamination of environment. In order to minimize foam solution flow testing and causing large disposal problems while still providing insurance of proper system and equipment performance, minimizing foam system flow to that described above will provide confidence in system performance, and by utilizing test and discharge containment practices in the system disposal problems will be minimized. These practices will provide proper stewardship of protecting the environment while providing properly installed and designed systems.

**A.12.9.4.2.2** See Annex D.

**A.12.9.4.3.1** Particular attention should be given to strainers or other small openings.

**A.12.9.7** See Figure A.12.9.7.

**A.13.1.1.1** An inspection contract for the equipment service tests and operation at regular intervals is recommended.

**A.13.1.5** Samples of foam liquid concentrate should be referred to the manufacturer to check its condition annually. Samples should be submitted in accordance with the manufacturer's recommended sampling procedure.

**A.13.1.6** Examples of system alterations include replaced or relocated equipment and replacement foam concentrate.

**A.13.2.1** Flushing of the concentrate pump might be necessary at periodic intervals or following complete discharge of concentrate.

**A.13.2.2** Regular service contracts are recommended.

Foam-Water Sprinkler System — General Information for	
_____	
_____	
_____	
System type _____	Date: _____
Proportioning method _____	<b>Flow test data:</b>
Foam concentrate type: _____	Static: _____ psi bar
Percent concentration _____	Residual: _____ psi bar
	Flow: _____ gpm L/min
	Pitot: _____ psi bar
	Date: _____
High-piled storage <input type="checkbox"/> Yes <input type="checkbox"/> No	Location: _____
Rack storage: <input type="checkbox"/> Yes <input type="checkbox"/> No	Location of auxiliary/low point drains:
Commodity class: _____	_____
Max. storage height _____ ft m	_____
Aisle width (min.) _____ ft m	_____
Encapsulation <input type="checkbox"/> Yes <input type="checkbox"/> No	Dry pipe/double interlock preaction valve
Solid shelving: <input type="checkbox"/> Yes <input type="checkbox"/> No	test results _____
<b>Flammable/</b>	<b>Original main drain test results:</b>
<b>combustible liquids:</b> <input type="checkbox"/> Yes <input type="checkbox"/> No	Static: _____ psi bar
Other storage: <input type="checkbox"/> Yes <input type="checkbox"/> No	Residual: _____ psi bar
	Venting valve location: _____
<b>Hazardous materials:</b> <input type="checkbox"/> Yes <input type="checkbox"/> No	
Location: _____	
<b>Where injection systems are used to treat MIC or corrosion:</b>	
Type of chemical: _____ Concentration: _____ For proper disposal, see: _____	
Name of contractor or designer: _____	
Address: _____	
Phone: _____	

FIGURE A.12.9.7 Foam-Water Sprinkler System – General Information.

**A.13.2.2.2.1** In some cases the primary discharge outlet on foam chambers must be temporarily blocked to prevent flow into the hazard area.

**A.13.2.2.2.2** See NFPA 25, Chapter 14, for alternative methods.

**A.13.2.2.3** Test results that deviate more than 10 percent from those recorded in acceptance testing should be investigated and, if necessary, discussed immediately with the manufacturer.

**A.13.3.1.1** To provide a means of periodically checking the performance of the proportioners used in foam sprinkler systems, a test connection should be provided. Typical test connections are illustrated in Figure A.6.4.10. Two options are possible in locating the proportioning controller in the sprinkler riser: before the main sprinkler valve or after the main sprinkler valve. If the proportioning controller is located after the main sprinkler valve, an additional supervised OS valve is needed to isolate the sprinkler overhead during the proportioner test. This is done to eliminate the problems caused by air cushions in wet pipe sprinkler systems or the servicing delays caused during charging and draining of preaction or deluge sprinkler systems. The test connection should be routed to a drain area for easy disposal of the solution produced during

the test. The manufacturer's test procedures should be followed closely.

**A.13.3.2.1** Directional-type foam-water discharge devices are quite often located in heavy traffic areas and are more apt to be dislocated compared to ordinary sprinkler locations. Of particular concern are low-level discharge devices in loading racks in and around low-level tankage and monitor-mounted devices that have been pushed out of the way for convenience. Inspection frequency might have to be increased accordingly. [25:A.11.2.4]

**A.13.3.2.1.4** Discharge devices are listed or approved for particular foam concentrates. [25:A.11.2.4.4]

**A.13.3.2.2.2** Water supply piping should be free of internal obstructions that can be caused by debris (e.g., rocks, mud, tubercles) or by closed or partially closed control valves. See Chapter 5 [of NFPA 25] for inspection and maintenance requirements. [25:A.11.2.5.2]

**A.13.3.2.5** Proportioning systems might or might not include foam concentrate pumps. If pumps are part of the proportioning system, the driver, pump, and gear reducer should be inspected in accordance with the manufacturer's recommenda-

tions, and the inspection can include items such as lubrication, fuel, filters, oil levels, and clutches. [25:A.11.2.8]

**A.13.3.2.5.4** In some cases, an adequate supply of foam liquid is available without a full tank. This is particularly true of foam liquid stored in nonmetallic tanks. If liquid is stored in metallic tanks, the proper liquid level should be one-half the distance into the expansion dome. [25:A.11.2.8.4]

**A.13.3.2.5.5.1(A)** The standard pressure proportioner is a pressure vessel. Although under normal standby conditions this type of proportioning system should not be pressurized, some installations allow for inadvertent pressurization. Pressure should be removed before inspection. [25:A.11.2.8.5.1.1]

**A.13.3.2.5.5.2(A)** The bladder tank proportioner is a pressure vessel. When inspecting for a full liquid tank, the manufacturer's instructions should be followed. If inspected incorrectly, the tank sight gauges could indicate a full tank when the tank actually is empty of foam liquid. Some foam liquids, due to their viscosity, might not indicate true levels of foam liquid in the tank where inspected via the sight glass.

**CAUTION:** Depending on system configuration, this type of proportioner system might be pressurized or nonpressurized under normal conditions. Pressure should be removed before inspection. [25:A.11.2.8.5.2.1]

**A.13.3.2.5.5.3(1)** See 13.3.2.3.1.

**A.13.3.2.5.5.3(2)** See Figure A.13.3.2.5.5.3(2).

**A.13.3.2.5.5.4(1)** See 13.3.2.3.1.

**A.13.3.2.5.5.4(2)** See Figure A.13.3.2.5.5.3(2).

**A.13.3.2.5.5.5(1)** See 13.3.2.3.1.

**A.13.3.2.5.5.5(2)** See Figure A.13.3.2.5.5.3(2).

**A.13.3.2.5.5.6(1)** See 13.3.2.3.1.

**A.13.3.2.5.5.6(2)** See Figure A.13.3.2.5.5.3(2)

**A.13.3.3** Operational tests generally should be comprised of the following:

- (1) A detection/actuation test with no flow to verify that all components such as automated valves, foam and water pumps, and alarms operate properly

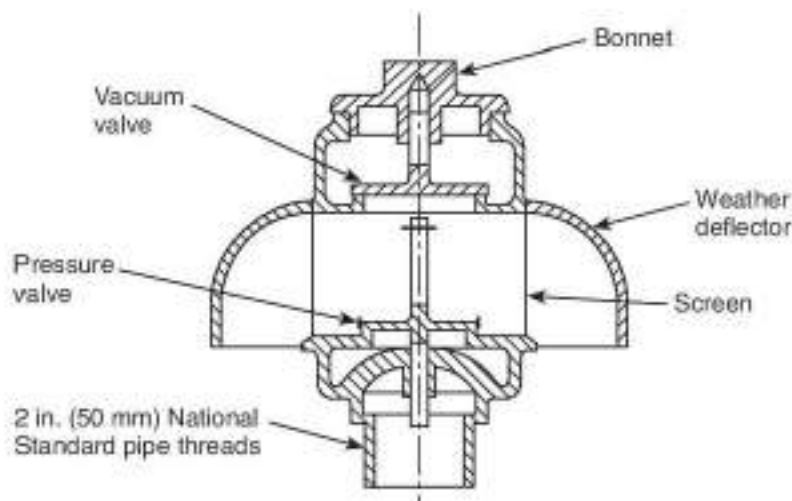
- (2) A water-only flow test to inspect piping continuity, discharge patterns, pressures, and line flushing
- (3) A foam flow test to verify solution concentration
- (4) Resetting of system to its normal standby condition, including draining of lines and filling of foam liquid tank [25:A.11.3]

**A.13.3.3.1** The property owner or designated representative should take care to prevent damage to equipment or the structure during the test. Damage could be caused by the system discharge or by runoff from the test site. It should be verified that there is adequate and unobstructed drainage. Equipment should be removed or covered as necessary to prevent damage. Means such as curbing or sandbagging should be used to prevent entry of the foam-water solution. [25:A.11.3.1]

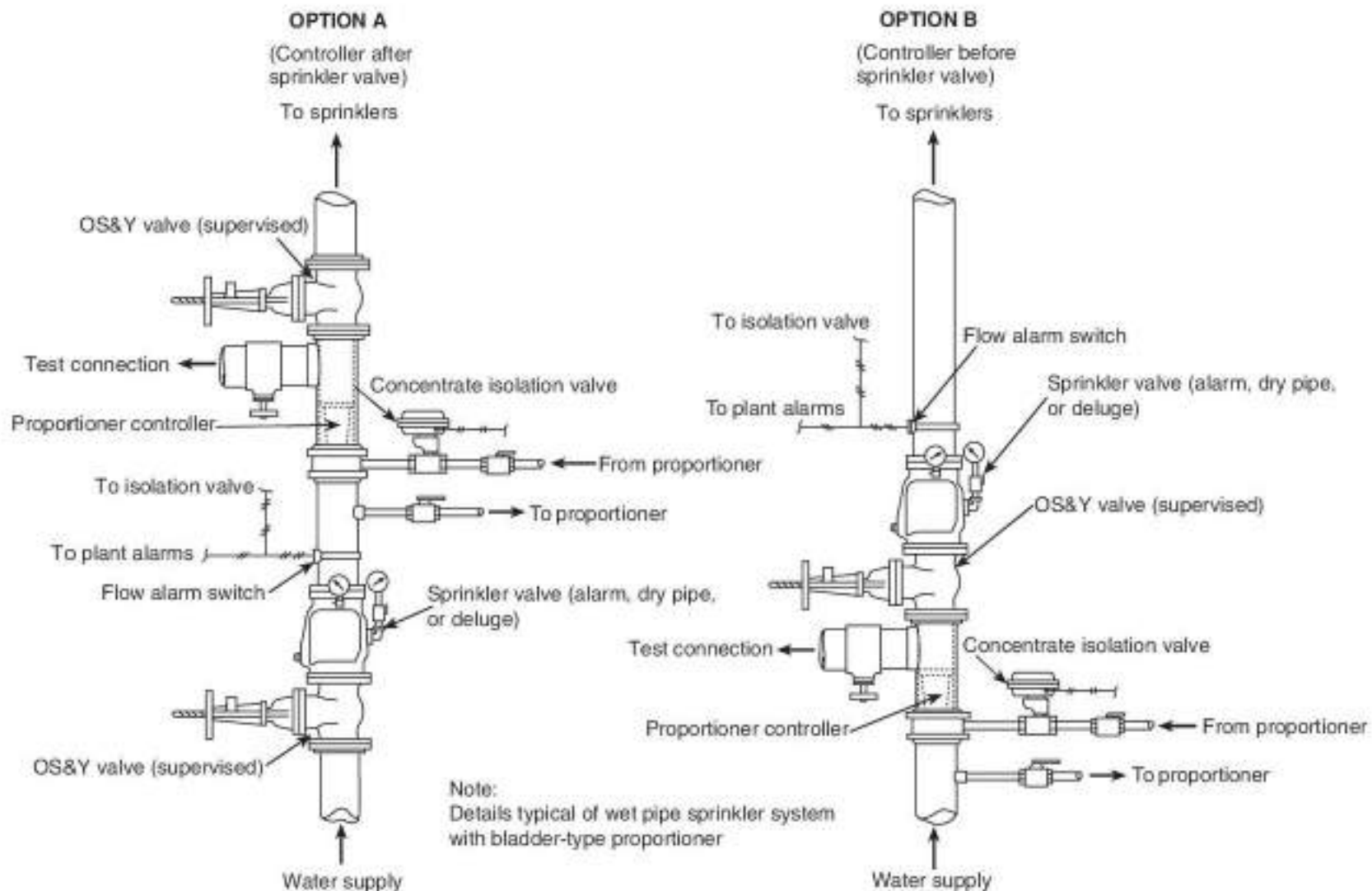
**A.13.3.3.2** An alternative method for achieving flow can be permitted to be an installation as shown in Figure A.13.3.3.2. This type of testing does not verify system pipe conditions or discharge device performance but only the water supply, foam concentrate supply, and proportioning accuracy. [25:A.11.3.2]

**A.13.3.3.2.7** Specific foam concentrates typically are listed or approved with specific sprinklers. Part of the approval and listing is a minimum sprinkler operating pressure. Sprinkler operating pressure affects foam quality, discharge patterns, and fire extinguishment (control) capabilities. Discharge pressures less than this specified minimum pressure should be corrected immediately; therefore, it is necessary to test under full flow conditions. [25:A.11.3.2.7]

**A.13.3.4** The maintenance items specified in the body of this standard are in addition to the typical inspection and test procedures indicated. Foam-water sprinkler systems are, as are all fire protection systems, designed to be basically maintenance free. There are, however, some areas that need special attention. Foam concentrate shelf life varies between liquids and is affected by factors such as heat, cold, dilution, contamination, and many others. As with all systems, common sense dictates those maintenance-sensitive areas that should be given attention. Routine testing and inspection generally dictate the need for additional maintenance items. Those maintenance items specified are key procedures that should be performed routinely. [25:A.11.4]



**FIGURE A.13.3.2.5.5.3(2)** Pressure Vacuum Vent. [25:Figure A.3.3.34]



**FIGURE A.13.3.3.2 Foam System/Test Header Combination.** [25:Figure A.11.3.2]

**A.13.3.4.4.2** Foam concentrates tend to settle out over time. Depending on the specific characteristics of the foam concentrate, sedimentation accumulates in the bottom of the storage vessel. This sediment can affect proportioning and foam concentrate integrity. Some concentrates tend to settle out more rapidly than others. If the annual samples indicate excessive sediment, flushing the tank could be required more frequently. [25:A.11.4.4.2]

**A.13.3.4.5.2** When hydrostatically testing bladder tanks, the generation of a pressure differential across the diaphragm could cause damage to the diaphragm. Tanks should be filled

with agent to no less than the normal fill capacity and air should be vented from inside and outside the bladder before pressurizing. [25:A.11.4.5.2]

### Annex B Storage Tank Protection Summary

*This annex is not a part of the requirements of this NFPA document but is included for informational purposes only.*

**B.1 Storage Tank Protection Summary Table.** See Table B.1.

Table B.1 Storage Tank Protection Summary

Foam Application Method	Fixed-Roof (Cone) Tanks and Pan-Type Floating Roof Tanks	No. of Chambers		Applicable Floating Roof Tanks (Open-Top or Covered) Annular Seal Area
<b>Top Side Foam Application</b>				
Number of foam outlets required	Up to 80 ft (24 m) dia.	1 foam chamber		1 — For each 40 ft (12 m) of circumference with a 12 in. (300 mm) high foam dam
	81 to 120 ft (25 to 37 m) dia.	2 foam chambers		
	121 to 140 ft (37 to 43 m) dia.	3 foam chambers		1 — For each 80 ft (24 m) of circumference with a 24 in. (609 mm) high foam dam
	141 to 160 ft (43 to 49 m) dia.	4 foam chambers		
	161 to 180 ft (49 to 55 m) dia.	5 foam chambers		(See 5.3.3.1 and Section 5.4.)
	181 to 200 ft (55 to 61 m) dia.	6 foam chambers		
	Over 201 ft (61 m) dia.	1 additional for each 5000 ft <sup>2</sup> (465 m <sup>2</sup> )		
	(See Table 5.2.5.2.1.)			
Hydrocarbon application rates	0.10 gpm/ft <sup>2</sup> (4.1 mm/min*) of liquid surface			0.30 gpm/ft <sup>2</sup> (12.2 mm/min*) of annular ring area, above seal, between tank wall and foam dam
	(See Table 5.2.5.2.2.)			
Polar solvent rates	See Manufacturer's Approval Report.			Not covered by NFPA 11
Hydrocarbon discharge times		Type I	Type II	
	Flash point 100°F to 140°F (38°C to 60°C)	20 min	30 min	20 min
	Flash point below 100°F (38°C)	30 min	55 min	
	Crude petroleum	30 min	55 min	(See Section 5.3.)
Polar solvents	Type I	30 min		Not covered by NFPA 11
	Type II	55 min		
<b>Foam Outlets Under Floating Roof Tank Seals or Metal Secondary Seal</b>				
Number required	Not applicable			Mechanical shoe seal 1 — For each 130 ft (40 m) of tank circumference (no foam dam required) Tube seal — Over 6 in. (150 mm) from top of seal to top of pontoon with foam outlets under metal weather shield or secondary seal 1 — For each 60 ft (18 m) of tank circumference (no foam dam required) Tube seal — Less than 6 in. (150 mm) from top of seal to top of pontoon with foam outlets under metal weather shield or secondary seal 1 — For each 60 ft (18 m) of tank circumference [foam dam at least 12 in. (300 mm) high required] (See 5.3.5.4.)
Hydrocarbon application rates	Not applicable			Top-of-seal protection with foam dam at 0.30 gpm/ft <sup>2</sup> (12.2 mm/min*) of annular ring area. All below-the-seal with or without foam dam at 0.50 gpm/ft <sup>2</sup> (20.4 mm/min*)
Discharge times	Not applicable			20 min — with foam dam or under metal weather shield or secondary seal
Polar solvents	Not applicable			Not covered by NFPA 11

(continues)

Table B.1 *Continued*

Foam Application Method	Fixed-Roof (Cone) Tanks and Pan-Type Floating Roof Tanks	No. of Chambers	Applicable Floating Roof Tanks (Open-Top or Covered) Annular Seal Area
<b>Foam Handlines and Monitors for Tank Protection</b>			
Size of tank	Monitors for tanks up to 60 ft (18 m) in diameter Hand hoses for tanks less than 30 ft (9 m) in diameter and less than 20 ft (6.1 m) high (See 5.2.4.2.2.)		Monitors not recommended  Handlines are suitable for extinguishment of rim fires in open-top floating roof tanks (See 5.3.4.)
Hydrocarbon application rates	0.16 gpm/ft <sup>2</sup> (6.5 mm/min*) (See 5.2.4.2.2.)		0.16 gpm/ft <sup>2</sup> (6.5 mm/min*) For rim fires in open-top floating roof tanks (See 5.2.4.2.2.)
Discharge times	Flash point below 100°F (38°C)	65 min	Use same times as for open-top floating roof tank rim fires
	Flash point 100°F to 140°F (38°C to 60°C)	50 min	
	Crude oil (See 5.2.4.2.2.)	65 min	
<b>Subsurface Application Outlets</b>			
Number required	Same as table for foam chambers. See above. (See 5.2.6.2.8.)		Not recommended
Hydrocarbon application rates	Minimum 0.1 gpm/ft <sup>2</sup> (4.1 mm/min*) of liquid surface Maximum 0.2 gpm/ft <sup>2</sup> (8.2 mm/min*) Foam velocity from outlet shall not exceed 10 ft/sec (3 m/sec) for Class IB liquids or 20 ft/sec (6 m/sec) for all other liquids (See 5.2.6.5.1.)		Not recommended
Discharge times	Flash point 100°F (38°C) to 140°F (60°C)	30 min	Not recommended
	Flash point below 100°F (38°C)	55 min	
	Crude petroleum (See 5.2.6.5.1.)	55 min	
Polar solvents	Not recommended		Not recommended

\*L/min-m<sup>2</sup> is equivalent to mm/min.

### Annex C Medium- and High-Expansion Foam

*This annex is not a part of the requirements of this NFPA document but is included for informational purposes only.*

**C.1** High-expansion foam is an agent for control and extinguishment of Class A and Class B fires and is particularly suited as a flooding agent for use in confined spaces. Development of the use of high-expansion foams for firefighting purposes started with the work of the Safety in Mines Research Establishment of Buxton, England, based on the difficult problem of fires in coal mines. It was found that by expanding an aqueous surface active agent solution to a semistable foam of about 1000 times the volume of the original solution, it was possible to force the foam down relatively long corridors, thus providing a means for transporting water to a fire inaccessible to ordinary hose streams.

This work led to the development of specialized high-expansion foam-generating equipment for fighting fires in mines, for application in municipal industrial firefighting, and for the protection of special hazard occupancies. Medium-expansion foam was developed to meet the need for a foam that was more wind resistant than high-expansion foam for outdoor applications.

*Description.* Medium- and high-expansion foams are aggregations of bubbles that are mechanically generated by the passage of air or other gases through a net, screen, or other porous medium that is wetted by an aqueous solution of surface active foaming agents. Under proper conditions, firefighting foams of expansions from 20:1 to 1000:1 can be generated. These foams provide a unique agent for transporting water to inaccessible places; for total flooding of confined spaces; and for volumetric displacement of vapor, heat, and smoke. Tests have shown that, under certain circumstances, high-expansion foam, when used in conjunction with water sprinklers, will provide more positive control and extinguishment than either extinguishment system by itself. High-piled storage of rolled paper stock is an example. Optimum efficiency in any one type of hazard depends to some extent on the rate of application and the foam expansion and stability. Medium- and high-expansion foams, which are generally made from the same type of concentrate, differ mainly in their expansion characteristics. Medium-expansion foam can be used on solid fuel and liquid fuel fires where some degree of in-depth coverage is necessary — for example, for the total flooding of small enclosed or partially enclosed volumes such as engine test cells and transformer rooms. Medium-expansion foam can provide quick and effective coverage of flammable liquid spill fires or some toxic liquid spills where rapid vapor suppression is essential. It is effective both indoors and outdoors.

High-expansion foam can also be used on solid- and liquid-fuel fires, but the in-depth coverage it provides is greater than for medium-expansion foam. Therefore, it is most suitable for filling volumes in which fires exist at various levels. For example, experiments have shown that high-expansion foam can be used effectively against high-rack storage fires, provided that the foam application is started early and the depth of foam is rapidly increased. It also can be used to extinguish fires in enclosures, such as in basement and underground passages, where it might be dangerous to send personnel. It can be used to control fires involving liquefied natural gases (LNGs) and liquefied petroleum gases (LPGs) and to provide vapor dispersion control for LNG and ammonia spills.

High-expansion foam is particularly suited for indoor fires in confined spaces. Its use outdoors can be limited because of the effects of wind and lack of confinement. Medium- and high-expansion foam have the following effects on fires:

- (1) Where generated in sufficient volume, medium- and high-expansion foam can prevent the free movement of air, which is necessary for continued combustion.
- (2) Where forced into the heat of a fire, the water in the foam is converted to steam, thus reducing the oxygen concentration by dilution of the air.
- (3) The conversion of the water to steam absorbs heat from the burning fuel. Any hot object exposed to the foam will continue the process of breaking the foam, converting the water to steam, and cooling.
- (4) Because of its relatively low surface tension, solution from the foam that is not converted to steam will tend to penetrate Class A materials. However, deep-seated fires might require overhaul.
- (5) Where accumulated in depth, medium- and high-expansion foam can provide an insulating barrier for protection of exposed materials or structures not involved in a fire and can thus prevent fire spread.
- (6) For LNG fires, high-expansion foam will not normally extinguish a fire, but it will reduce the fire intensity by blocking radiation feedback to the fuel.
- (7) Class A fires are controlled when the foam completely covers the fire and burning material. If the foam is sufficiently wet and is maintained long enough, the fire can be extinguished.
- (8) Class B fires involving high-flash-point liquids can be extinguished when the surface is cooled below the flash point. Class B fires involving low-flash-point liquids can be extinguished when a foam blanket of sufficient depth is established over the liquid surface. Refrigerated or cryogenic liquefied flammable gas fires can be safely controlled, and vapor concentrations downwind of unignited spills can be reduced by application of high-expansion foam when the vapor density at ambient temperature and pressure is less than that of air. High-expansion foam should not be applied to refrigerated liquefied petroleum gas (LPG) fires unless careful consideration is given to the resulting possibly hazardous condition. Extinguishment can occur with evolution of heavier-than-air vapors beneath the foam blanket. The vapors will accumulate or drain from beneath the foam blanket to low areas with the danger of vapor cloud formation or reignition or both. For LPG fire control, see *Control and Extinguishment of LPG Fires*, D. W. Johnson, et al.

### Annex D Tests for Foam Systems

*This annex is not a part of the requirements of this NFPA document but is included for informational purposes only.*

#### D.1 Procedures for Measuring Expansion and Drainage Rates of Foams.

**D.1.1 Foam Sampling.** The object of foam sampling is to obtain a sample of foam typical of the foam to be applied to burning surfaces under anticipated fire conditions. Because foam properties are readily susceptible to modification through the use of improper techniques, it is extremely important that the prescribed procedures are followed.

A collector is designed chiefly to facilitate the rapid collection of foam from low-density patterns. In the interest of standardization, it is used also for all sampling, except where pressure-produced foam samples are being drawn from a line tap. A backboard is inclined at a 45-degree angle suitable for use with vertical streams falling from overhead applicators as well as horizontally directed streams. [See Figure D.1.1(a) and Figure D.1.1(b).]

The standard container has a nominal 4 in. (100 mm) inside diameter with a volume of 54 fl oz (1600 mL) and preferably made of  $\frac{1}{16}$  in. (1.6 mm) thick aluminum, brass, or plastic. The bottom is sloped to the center, where a  $\frac{1}{4}$  in. (6 mm) drain fitted with a  $\frac{1}{4}$  in. (6 mm) valve is provided to draw off the foam solution. [See Figure D.1.1(b).]

**D.1.2 Turrets or Handline Nozzles.** It is presumed that the turret or nozzle is capable of movement during operation to facilitate collection of the sample. It is important that the foam samples taken for analysis represent as nearly as possible the foam reaching the burning surface in a normal firefighting procedure. With adjustable stream devices, samples should be taken from both the straight stream position and the fully dispersed position and possibly from other intermediate positions. Initially, the collector should be placed at the proper distance from the nozzle to serve as the center of the ground pattern. The nozzle or turret should be placed in operation while it is directed off to one side of the collector.

After the pressure and operation have become stabilized, the stream is swung over to center on the collector. When a sufficient foam volume has accumulated to fill the sample containers, usually within only a few seconds, a stopwatch is started for each of the two samples in order to provide the "zero" time for the drainage test described later. Immediately, the nozzle is turned away from the collector, the sample containers removed, and the top struck off with a straight edge. After all foam has been wiped off from the outside of the container, the sample is ready for analysis.

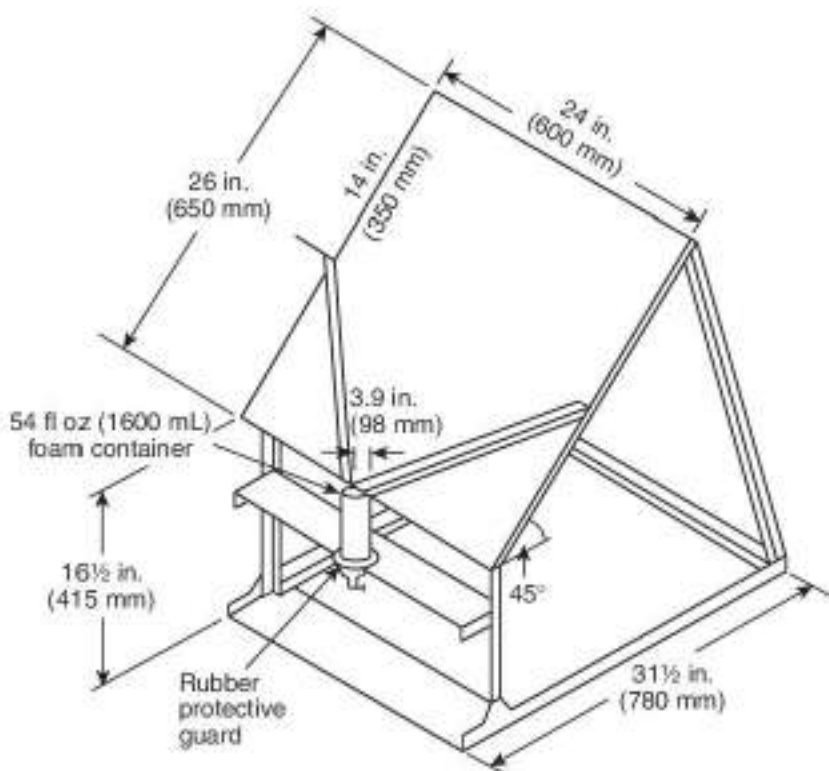


FIGURE D.1.1(a) Foam Sample Collector.

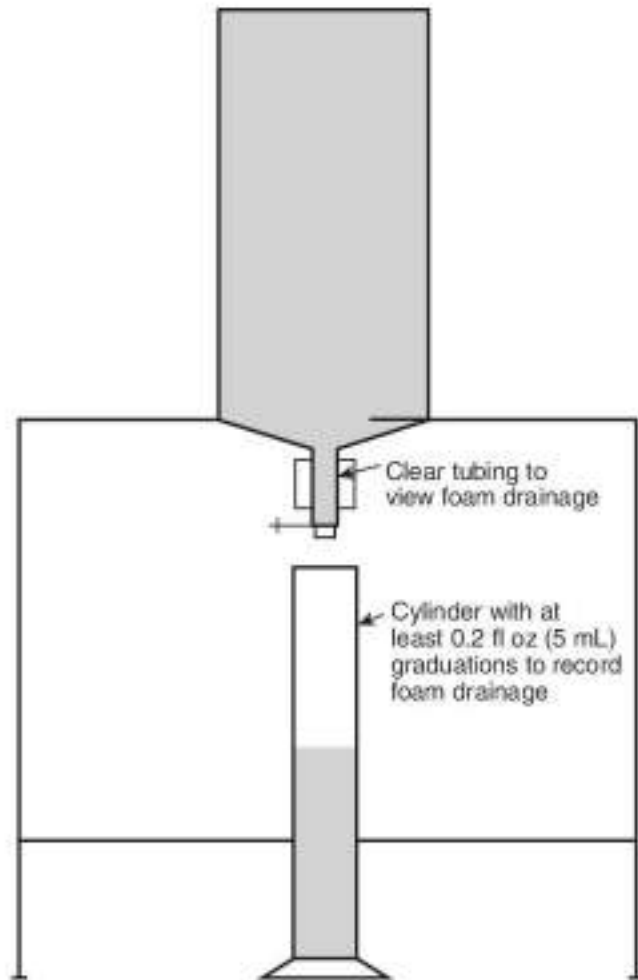


FIGURE D.1.1(b) 54 fl oz (1600 mL) Foam Container.

**D.1.3 Overhead Devices.** It is presumed that the devices are fixed and not capable of movement. Prior to starting up the stream, the collector is situated within the discharge area where it is anticipated a representative foam pattern will occur. The two sample containers are removed before the collector is positioned. The foam system is activated and permitted to achieve equilibrium, after which time the technician, wearing appropriate clothing, enters the area without delay. The sample containers are placed and left on the collector board until adequately filled. Stopwatches are started for each of the samples to provide the "zero" time for the drainage rate test described later. During the entry and retreat of the operator through the falling foam area, the containers should be suitably shielded from extraneous foam. Immediately after the samples are removed from under the falling foam, the top should be struck off with a straight edge and all foam wiped off from the outside of the container. The sample is then ready for analysis.

**D.1.4 Pressure Foam.** It is presumed that foam is flowing under pressure from a foam pump or high-pressure aspirator toward an inaccessible tank outlet. A 1 in. (25 mm) pipe tap fitted with a globe valve should be located as close to the point of foam application as practicable. The connection should terminate in an approximate 18 in. (450 mm) section of flexible rubber tubing to facilitate filling the sample container. When drawing the sample, the valve should be opened as wide as possible without causing excessive splashing and air entrainment in the container. Care should be exercised to eliminate air pockets in the sample. As each container is filled, a stopwatch is started to provide the "zero" time for the drainage test described later. Any excess foam is struck off the top with a



straight edge, and all foam clinging to the outside of the container is wiped off. The sample is then ready for analysis.

**D.1.5 Foam Chambers.** In some instances where the foam makers are integral with the foam chambers on the top ring of a tank, the methods of sampling described in D.1.1 through D.1.4 might not be workable. In this case, it will be necessary to improvise, making sure any unusual procedures or conditions are pointed out in reporting the results. Where access can be gained to a flowing foam stream, the container can be inserted into the edge of the stream to split off a portion for the sample. The other alternative is to scoop foam from a layer or blanket already on the surface. Here an attempt should be made to obtain a full cross section of foam from the entire depth but without getting any fuel below the foam layer. The greatest difficulty inherent in sampling from a foam blanket is the undesirable lag-in-time factor involved in building up a layer deep enough to scoop a sample. At normal rates of application, it can take a few minutes to build up the several inches in depth required, and this time is likely to affect the test results. The degree of error thus incurred will in turn depend on the type of foam involved, but it can vary from zero percent to several hundred percent. In a Moeller tube installation, it is advisable to sample right alongside the tube as foam oozes out in sufficient volume. Immediately after filling the container, a stopwatch is started to provide the "zero" time for the drainage test described later. Any excess foam is struck off the top with a straight edge, and all foam wiped off from the outside of the container. The sample is then ready for analysis.

**D.1.6 Foam Testing.** The foam samples, as obtained in the procedures described in D.1.1 through D.1.5, are analyzed for expansion, 25 percent drainage time, and foam solution concentration. It is recommended that duplicate samples be obtained whenever possible and the results averaged for the final value. However, when a shortage of personnel or equipment or both creates a hardship, one sample should be considered acceptable.

The following apparatus is required:

- (1) Two 54 fl oz (1600 mL) sample containers
- (2) One foam collector board
- (3) One balance [triple beam balance, 5.7 lb (2610 g) capacity]

**D.1.7 Procedure.** Prior to the testing, the empty containers fitted with a drain hose and clamp should be weighed to obtain the tare weight. (All containers should be adjusted to the same tare weight to eliminate confusion in handling.) Each foam sample is weighed to the nearest gram and the expansion calculated from the following equation:

$$\frac{54 \text{ fl oz}}{(\text{full weight} - \text{empty weight})} = \text{Expansion} \quad [\text{D.1.7}]$$

**D.1.8 Foam 25 Percent Drainage Time Determination.** The rate at which the foam solution drops out from the foam mass is called the drainage rate and is a specific indication of degree of water retention ability and the fluidity of the foam. A single value is used to express the relative drainage rates of different foams in the "25 percent drainage time," which is the time in minutes that it takes for 25 percent of the total solution contained in the foam in the sample containers to drain.

The following apparatus are required:

- (1) Two stopwatches
- (2) One sample stand
- (3) 3.38 fl oz (100 mL) capacity plastic graduates

**D.1.9 Procedure.** This test is performed on the same sample as used in the expansion determination. Dividing the net weight of the foam sample by 4 will give the 25 percent volume (in milliliters) of solution contained in the foam. To determine the time required for this volume to drain out, the sample container should be placed on a stand, as indicated in Figure D.1.1(b), and the accumulated solution in the bottom of the container should be drawn off into a graduate at regular, suitable intervals. The time intervals at which the accumulated solution is drawn off are dependent on the foam expansion. For foams of expansion 4 to 10, 30-second intervals should be used, and for foams of expansion 10 and higher, 4-minute intervals should be used because of the slower drainage rate of these foams. In this way, a time-drainage-volume relationship is obtained, and after the 25 percent volume has been exceeded, the 25 percent drainage time is interpolated from the data. The following example shows how this is done. The net weight of the foam sample is 6 oz (180 grams). Since 1 gram of foam solution occupies a volume of essentially 0.03 fl oz (1 mL), the total volume of foam solution contained in the given sample is 6.1 fl oz (180 mL).

[D.1.9a]

$$\text{Expansion} = \frac{54 \text{ fl oz}}{6.1 \text{ fl oz}} = 8.9$$

[D.1.9b]

$$25\% \text{ volume} = \frac{6.1 \text{ fl oz}}{4} = 1.52 \text{ fl oz}$$

The time-solution volume data is recorded as shown in Table D.1.9.

The 25 percent volume of 1.52 fl oz (44 mL) falls between the 2.0- and 2.5-minute period. The proper increments to add to the lower value of 2.0 minutes is determined by interpolation of the data:

[D.1.9c]

$$\frac{1.52 \text{ fl oz (25\% vol.)} - 1.35 \text{ fl oz (2.0 min vol.)}}{1.69 \text{ fl oz (2.5 min vol.)} - 1.35 \text{ fl oz (2.0 min vol.)}} = \frac{0.17}{0.34} = \frac{1}{2}$$

The 25 percent drainage time is halfway between 2.0 and 2.5 minutes, or 2.25 minutes, which is rounded off to 2.3 minutes.

An effort should be made to conduct foam tests with water temperatures between 60°F and 80°F (15.6°C and 26.7°C). The water, air, and foam temperatures should be noted in the results. Lower water temperature tends to depress the expansion values and increase the drainage time values. When handling fast-draining foams, remember that they lose their solution rapidly and that the expansion determination should be carried out with speed in order not to miss the 25 percent drainage volume. The stopwatch is started at the time the foam container is filled and continues to run during the time the sample is being weighed. It is recommended that expansion

weighing be deferred until after the drainage curve data has been received.

## D.2 Foam Solution Concentration Determination.

**D.2.1 General.** This test is used to determine the percent concentration of a foam concentrate in the water being used to generate foam. It typically is used as a means of determining the accuracy of a system's proportioning equipment. It is also used to measure the concentration of surrogate liquids described in D.5.2.2 or to perform the initial foam concentration test using the water equivalency method described in D.5.2.3. If the level of foam concentrate injection varies widely from that of the design, it can abnormally influence the expansion and drainage foam quality values, which can influence the foam's fire performance. There are two acceptable methods for measuring foam concentrate percentage in water. Both methods are based on comparing foam solution test samples to premeasured solutions that are plotted on a baseline graph of percent concentration versus instrument reading.

**D.2.1.1 Refractive Index Method.** A handheld refractometer is used to measure the refractive index of the foam solution samples. This method is not particularly accurate for AFFF or alcohol-resistant AFFFs since they typically exhibit very low refractive index readings. For this reason, the conductivity method might be preferred where these products are used.

**D.2.1.1.1 Equipment.** A base (calibration) curve is prepared using the following apparatus:

- (1) Four 35 fl oz (1000 mL) or larger plastic bottles with caps
- (2) One measuring pipette [3.4 fl oz (100 mL)] or syringe [3.4 fl oz (100 cc)]
- (3) One 35 fl oz (1000 mL) or larger graduated cylinder
- (4) Three plastic-coated magnetic stirring bars
- (5) One digital refractometer
- (6) Standard graph paper or electronic means
- (7) Ruler or other straight edge

**D.2.1.1.2 Procedure.** Using water and foam concentrate from the system to be tested, make up three standard solutions using the 35 fl oz (1000 mL) or larger graduate. These samples should include the nominal intended percentage of injection, the nominal percentage plus 1 percent, and the nominal percentage minus 1 percent. Place the water in the 35 fl oz (1000 mL) or larger graduate (leaving adequate space for the foam concentrate), and then carefully measure the foam concentrate samples into the water using the syringe. Use care not to pick up air in the foam concentrate samples. Pour each measured foam solution from the 35 fl oz (1000 mL) or larger

graduate into a 35 fl oz (1000 mL) plastic bottle. Each bottle should be marked with the percent solution it contains. Add a plastic stirring bar to the bottle, cap it, and shake it thoroughly to mix the foam solution.

After the foam solution samples are thoroughly mixed, a refractive index reading should be taken of each percentage foam solution sample. This is done by placing a few drops of the solution on the refractometer prism, closing the cover plate, and observing the scale reading at the dark field intersection. Since the refractometer is temperature compensated, it can take 10 seconds to 20 seconds for the sample to be read properly. It is important to take all refractometer readings at ambient temperatures of 50°F (10°C) or above. Using standard graph paper, plot the refractive index readings on one axis and the percent concentration readings on the other. (See Figure D.2.1.1.2.)

This plotted curve will serve as the known baseline for the test series. Set the solution samples aside in the event the measurements need to be checked.

**D.2.1.1.3 Sampling and Analysis.** Collect foam solution samples from the proportioning system, using care to be sure the sample is taken at an adequate distance downstream from the proportioner being tested. Take refractive index readings of the sample and compare them to the plotted curve to determine the percentage of the samples.

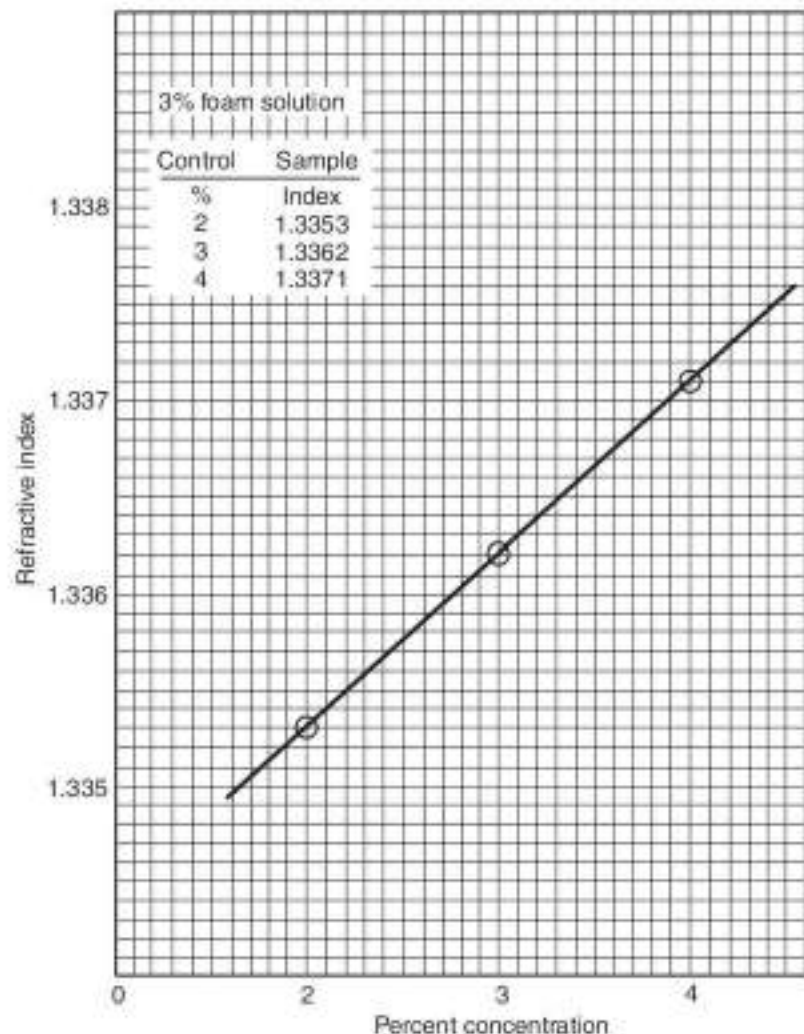


FIGURE D.2.1.1.2 Typical Graph of Refractive Index Versus Foam Concentration.

Table D.1.9 Foam Sample Drain Time

Time (minutes)	Drained Solution Volume	
	fl oz	mL
0	0	0
0.5	0.34	10
1.0	0.68	20
1.5	1.0	30
2.0	1.4	40
2.5	1.7	50
3.0	2.0	60

**D.2.1.2 Conductivity Method.** This method is based on changes in electrical conductivity as foam concentrate is added to water. A handheld conductivity meter, shown in Figure D.2.1.2, is used to measure the conductivity of foam solutions in microsiemen units. Conductivity is a very accurate method, provided there are substantial changes in conductivity, as foam concentrate is added to the water in relatively low percentages. Since salt or brackish water is very conductive, this method might not be suitable due to small conductivity changes as foam concentrate is added. It will be necessary to make foam and water solutions in advance to determine if adequate changes in conductivity can be detected if the water source is salty or brackish.

**D.2.1.2.1 Equipment.** Prepare a base (calibration) curve using the following apparatus:

- (1) Four 35 fl oz (1000 mL) or larger plastic bottles with caps
- (2) One measuring pipette [3.4 fl oz (100 mL)] or syringe [0.34 fl oz (10 cc)]
- (3) One 35 fl oz (1000 mL) or larger graduated cylinder
- (4) Three plastic-coated magnetic stirring bars
- (5) A portable temperature compensated conductivity meter
- (6) Standard graph paper or electronic equivalent
- (7) Ruler or other straight edge

**D.2.1.2.2 Procedure.** Using the water and foam concentrate from the system to be tested, make up three standard solutions using the 35 fl oz (1000 mL) or larger graduate. These samples should include the nominal intended percentage of injection, the nominal percentage plus 1 percent, and the nominal percentage minus 1 percent. Place the water in the 35 fl oz (1000 mL) or larger graduate (leaving adequate space for the foam concentrate), and then carefully measure the foam concentrate samples into the water using the syringe. Use care not to pick up air in the foam concentrate samples. Pour each measured foam solution from the 35 fl oz (1000 mL) or larger graduate into a 35 fl oz (1000 mL) or larger plastic bottle. Each bottle should be marked with the percent solution it contains. Add a plastic stirring bar to the bottle, cap it, and shake it thoroughly to mix the foam solution.

After making the three foam solutions in this manner, measure the conductivity of each solution. Refer to the instructions that came with the conductivity meter to determine proper procedures for taking readings. It will be necessary to switch the meter to the correct conductivity range setting in order to



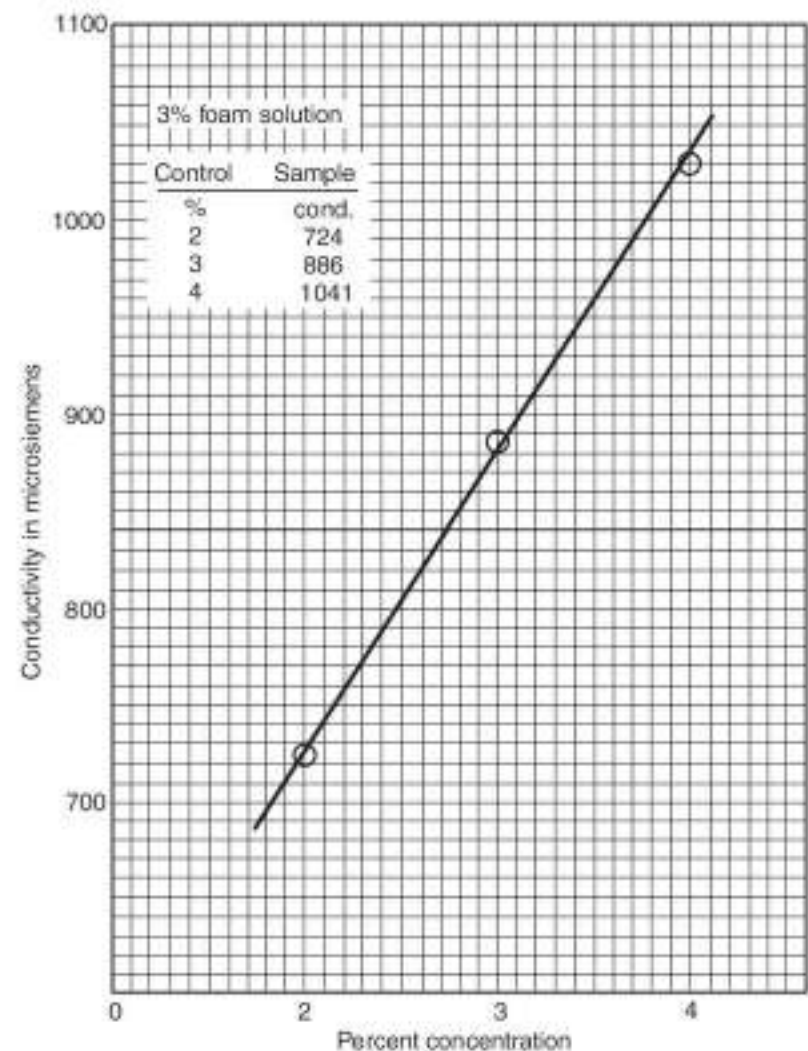
**FIGURE D.2.1.2** Equipment Needed for Conductivity Method of Proportioning Measurement.

obtain a proper reading. Most synthetic-based foams used with freshwater result in foam solution conductivity readings of less than 2000 microsiemens. Protein-based foams generally produce conductivity readings in excess of 2000 in freshwater solutions. Due to the temperature compensation feature of the conductivity meter, it can take a short time to obtain a consistent reading.

Once the solution samples have been measured and recorded, set the bottles aside for control sample reference. The conductivity readings then should be plotted on the graph paper. (See Figure D.2.1.2.2.) It is most convenient to place the foam solution percentage on the horizontal axis and the conductivity readings on the vertical axis.

Use a ruler or straight edge to draw a line that approximates connecting all three points. While it might not be possible to hit all three points with a straight line, they should be very close. If not, repeat the conductivity measurements and, if necessary, make new control sample solutions until all three points plot in a nearly straight line. This plot will serve as the known base (calibration) curve to be used for the test series.

**D.2.1.2.3 Sampling and Analysis.** Collect foam solution samples from the proportioning system, using care to be sure the sample is taken at an adequate distance downstream from the proportioner being tested. Using foam solution samples that are allowed to drain from expanded foam can produce misleading conductivity readings and, therefore, this procedure is not recommended.



**FIGURE D.2.1.2.2** Typical Graph of Conductivity Versus Foam Concentration.

Once one or more samples have been collected, read their conductivity and find the corresponding percentage from the base curve prepared from the control sample solutions.

**D.3 Interpretation of Foam Test Results.** Where the intent of conducting the tests described in Sections D.1 and D.2 is to check the operating efficiency or standby condition, it is necessary only to compare the results with the manufacturers' standards. The manufacturers should be consulted if any appreciable deviations occur.

After a short period of experience with the test procedure, it will be observed that foams exist in a wide variety of physical properties. Not only can the expansion vary in value from 3 to 20, but at the same time the 25 percent drainage time can also vary from a few seconds to several hours.

These variations result in foams that range in appearance from a watery consistency to the stiffest whipped cream.

It is observed here that the foam solution rapidly drains out of the very watery foams, while the dropout is very slow with the stiff foams. It is not possible to make a foam that is fluid and free flowing and, at the same time, able to hold onto its foam solution. From the standpoint of quickly forming a cohesive foam blanket and rapid flow around obstructions, a fluid-type foam is desirable; however, foams of this nature lose their water more rapidly, which may reduce their resistance to flame burn-back and shorten the effective time of sealability. On the other hand, foams that retain their water for a long time are stiff and do not spread readily over a burning area. Thus, good firefighting practice indicates a compromise between these two opposite foam properties in order to obtain an optimum foam. An optimum foam is defined as that foam, with physical properties defined by expansion and drainage time, that will extinguish a fire faster, at a lower application rate, or with less water consumed than any other foam.

Numerous test fires conducted in the course of research and development work have shown that the characteristics of an optimum foam depend on the type of the fire and the manner of foam application. Experience over many years of satisfactory results has supported this viewpoint. For example, in a large fuel storage tank, foam may be gently applied from one chamber and be required to flow 65 ft (20 m) across a burning surface to seal off the fuel. In this case, the optimum foam is physically different from that applied in a splashing manner from a turret that can direct the foam application as needed, where the foam has to flow no more than 42 in. (1050 mm) to form a seal. The formation of a complete specification for the various methods of application has not as yet been accomplished; however, for guidance purposes, the best data available to date are presented.

**D.4 Inspection of Foam Concentrate.** In order to determine the condition of the apparatus and foam concentrate and in order to train personnel, foam should be produced annually with portable foam nozzles. Following this operation, the concentrate container (can) should be cut open and examined for deposits of sludge, scale, and so forth, which are capable of impairing the operation of the equipment.

Where the concentrate is stored in tanks, a sample should be drawn from the bottom of the tank annually, and actual foam production tested as specified above, using a portable foam nozzle and the withdrawn sample to verify the quality of foam

produced. In the event that sludging of the concentrate is noted, the manufacturer should be promptly consulted.

#### D.5 Foam Injection Rate Tests.

**D.5.1 Test Using Foam Concentrate.** The major focus when evaluating foam system performance is to confirm proper function of the foam proportioning system. This is done by conducting a foam injection rate test. Manufacturer's recommendations should be followed. It is recommended that the test be performed at the design demand flow rate of the system and at the lowest possible design point.

The rate of concentrate flow can be measured by timing a given displacement from the storage tank. Solution concentration can be measured by either refractometric or conductivity means (see Section D.2), or it can be calculated from solution and concentrate flow rates. Solution flow rates can be calculated by utilizing recorded inlet or end-of-system operating pressures, or both.

#### D.5.2 Tests Using Alternative Listed and Approved Methods.

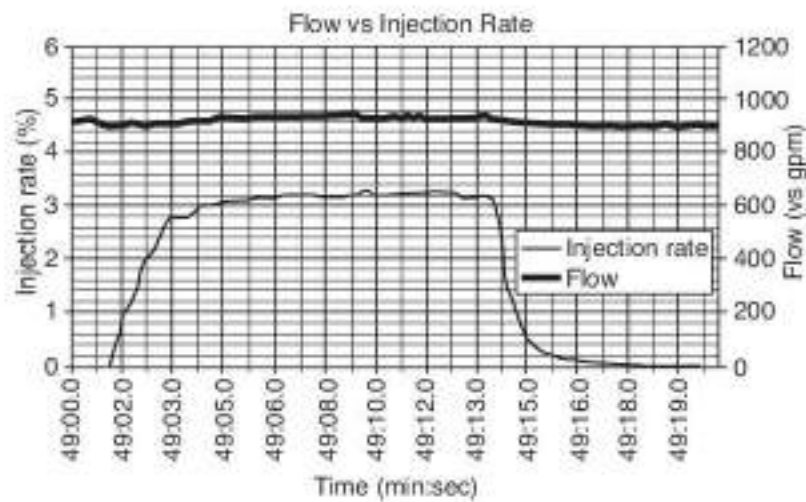
**D.5.2.1 General.** Foam injection rate testing can now be performed using surrogate, nonfoaming, environmentally-acceptable, test liquids in lieu of foam discharge, or water as a surrogate for the foam concentrate. Both methods have advantages and disadvantages, but both serve to reduce the need to discharge foam concentrate. It is recommended that system proportioning verification discharge tests be performed at the actual demand of the system, and at the lowest possible actual demand flow.

Both methods employ portable data acquisition instrumentation and software to enable fast, real-time data monitoring and recording. Typically measurements include conductivity (translates to percent injection rate) of the proportioned solution stream, system flow rate, and several pressures on the proportioning system. Conductivity and flow are measured by means of in-line electronic instrumentation installed in flow meters that are placed on the test outlet side of the proportioning system. Pressure transducers are installed temporarily at strategic locations where measurements are desired.

**D.5.2.2 Surrogate Liquid Test Method.** In this approach, surrogate test liquids are formulated specifically to simulate the flow behavior (viscosity characteristics) and approximate conductivity or refractive index of the foam concentrate used in the system. An example of a graph generated from the recorded data is shown in Figure D.5.2.2(a).

For initial system commissioning, the surrogate liquid can be placed directly in the foam system tank for injection rate tests and then flushed out before filling the tank with foam concentrate. After the system has been filled with foam concentrate it can still be tested using a surrogate test liquid, but installation of some additional connections on the proportioning system piping are required. These additional connections enable the surrogate test liquid to be injected into the proportioning system in place of the foam concentrate already in the foam storage tank. Since there are many types of proportioning systems, the test setup arrangement varies according to the system type.

Figure D.5.2.2(b) through Figure D.5.2.2(h) are illustrations of surrogate liquid test setup arrangements for types of the most commonly used proportioning systems.



**FIGURE D.5.2.2(a) Plot of Real-Time Test Data Gathered from Surrogate Liquid Injection Rate Test.**

**D.5.2.3 Water Equivalency Method.** In this approach, water is used as a surrogate liquid in place of foam concentrate. The initial acceptance test(s) are conducted with the actual foam concentrate using equipment similar to that shown in Figure D.5.2.2(b) and Figure D.5.2.2(g); real-time pressure, flow, and conductivity measurements are recorded with the actual foam concentrate to determine that the system is proportioning accurately. Immediately following this test, a water equivalency test at the exact same pressure and flows as in the initial foam discharge test is performed after isolating the foam concentrate tank. Example test setups are shown in Figure D.5.2.3(a) and Figure D.5.2.3(b). This provides a baseline for comparison using water only for follow-on routine inspections and tests.

This method is appropriate for use with aqueous film-forming foam (AFFF) and high-expansion foam. It should not be used with viscous foam concentrates such as alcohol-resistant aqueous film-forming foam (AR-AFFF).

**D.5.3 Alternative Test Methods.** Surrogate methods for foam injection tests continue to be developed. The following techniques describe alternative methods that have been proposed as alternatives to foam injection rate testing, but they have yet to undergo formal listing or approval processes.

**D.5.3.1 Vehicle Tests.** ARFF and municipal firefighting vehicles are required to go through periodic foam nozzle discharge tests to ensure proper function of their foam proportioning systems. Traditionally, these tests have been done by discharging foam solution with all of the associated issues involved in containment and disposal. New technology is now available to enable testing these vehicles using water or a water-based surrogate liquid containing an environmentally benign biodegradable dye. The dye in the surrogate test liquid can be detected in the proportioned solution stream by means of colorimetry instrumentation. When water is used as the surrogate test liquid, a flow meter system measures the water injection rate.

**D.5.3.2 Positive Pressure Pump Direct Injection.** A water motor foam-proportioning pump system provides a means to verify concentrate proportioning by the flow method described in D.5.1. The volumetric flow rate of the extinguishing water, as well as the volumetric flow rate of the foam concentrate, is measured using pressure/flow instrumentation, without mixing both liquids. These flows can be used to calculate the proportioning rate. By using an adjustable pressure relief valve at the positive displacement foam pump, the back pressure on that pump can be set to the same pressure level as the extinguishing water.

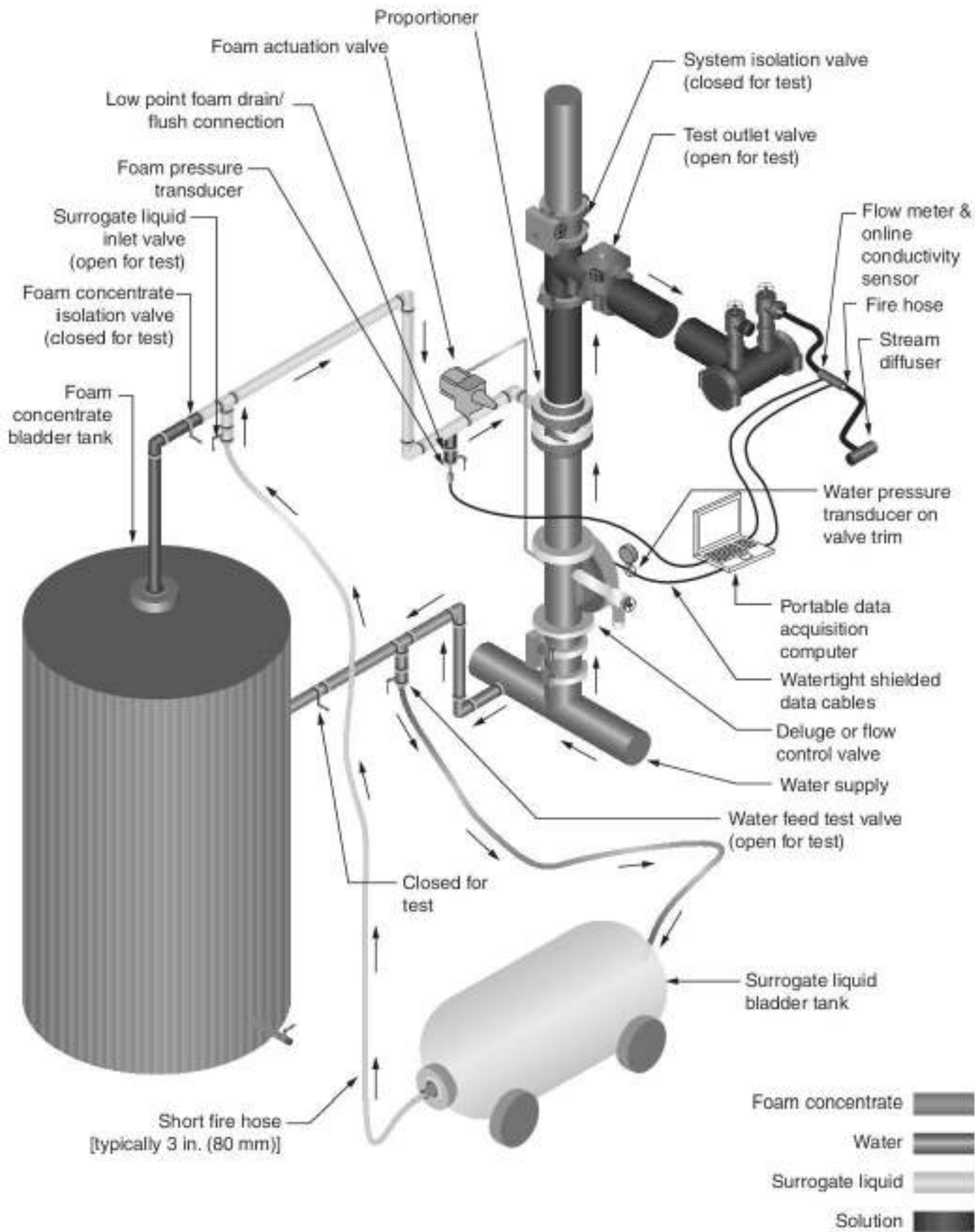


FIGURE D.5.2.2(b) Bladder Tank Proportioning System Setup for Surrogate Liquid Type Test.

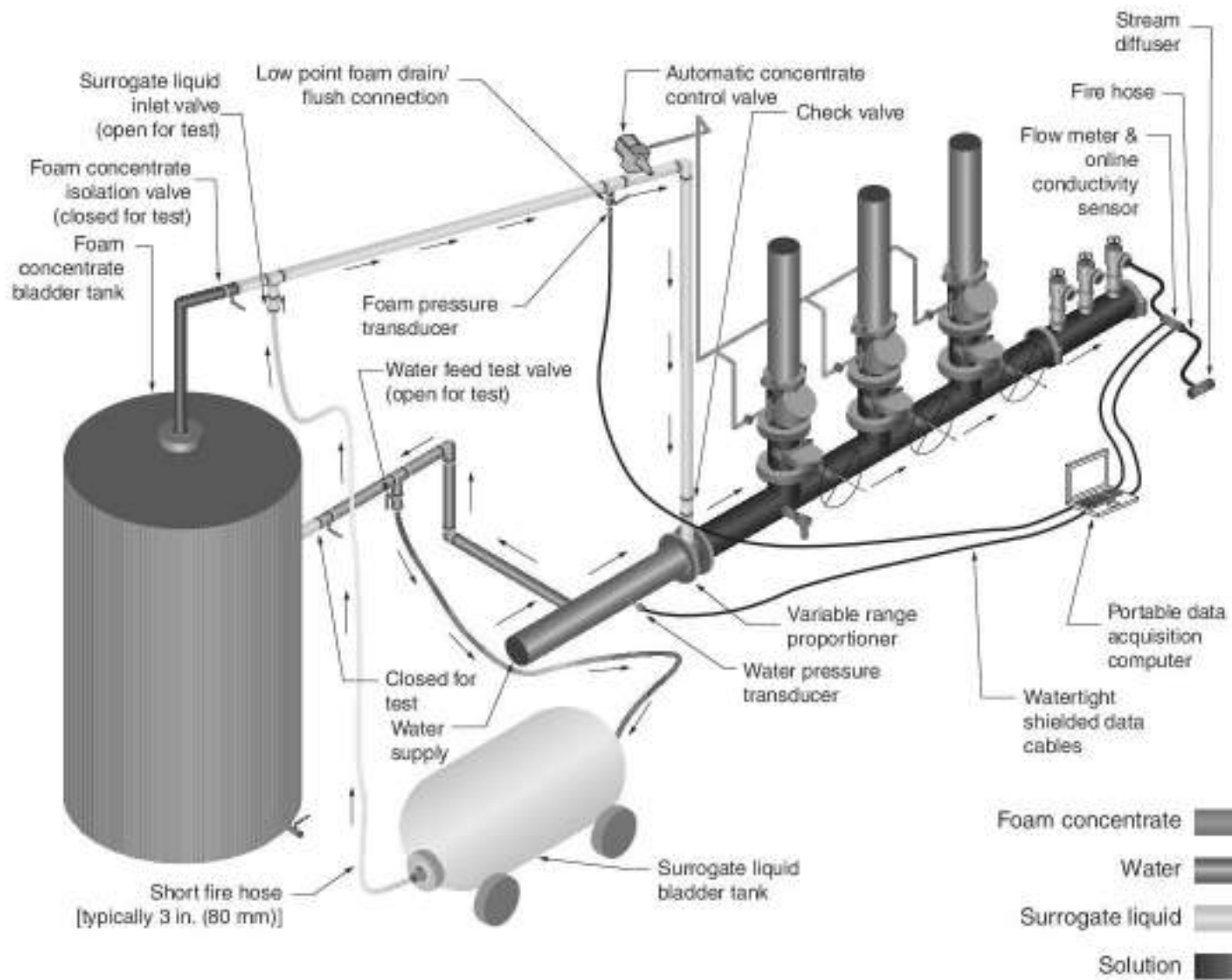


FIGURE D.5.2.2(c) Bladder Tank Variable Range Proportioning System Setup for Surrogate Liquid Type Test.

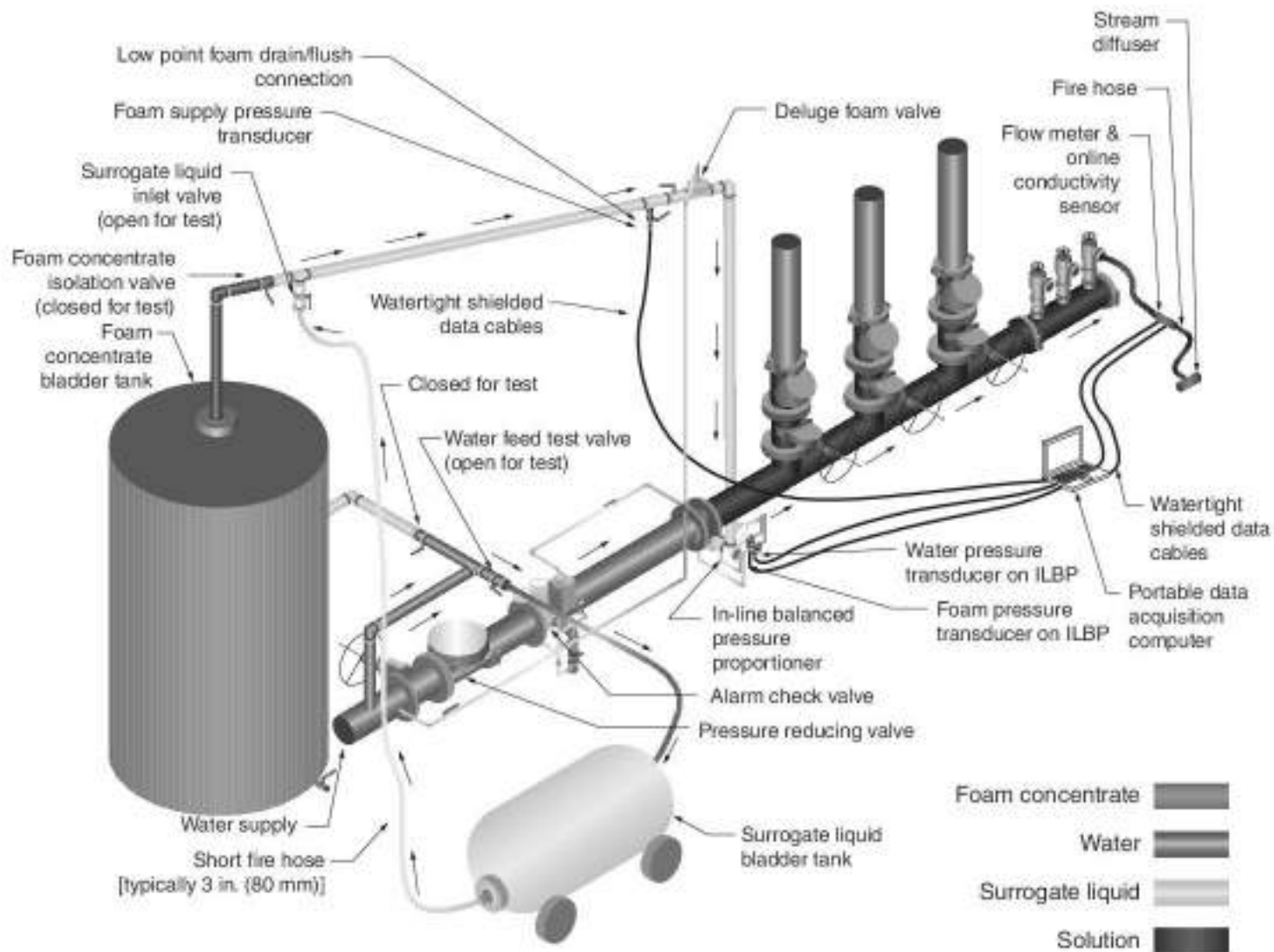


FIGURE D.5.2.2(d) Bladder Tank Low Flow Proportioning System Setup for Surrogate Liquid Type Test.



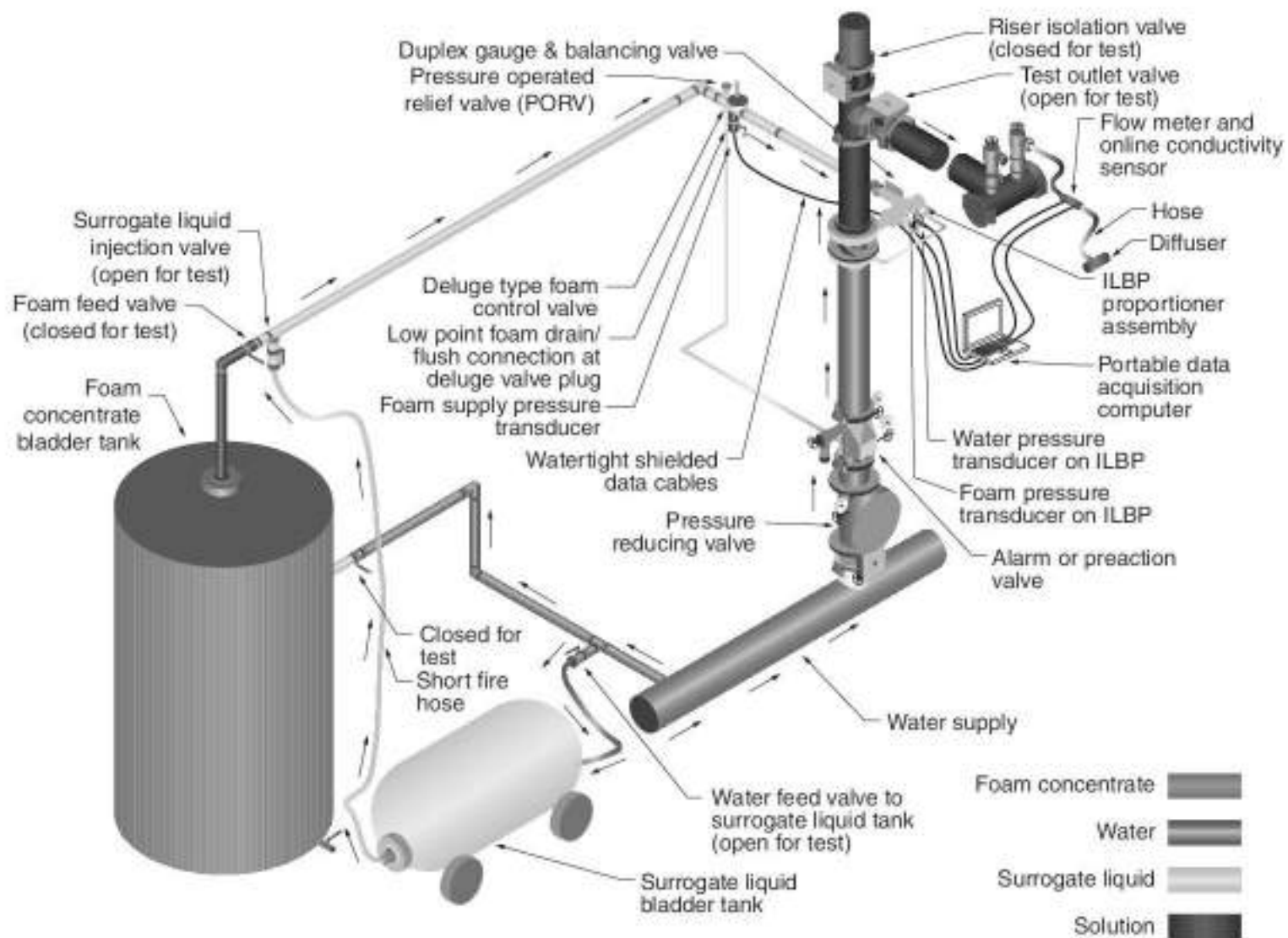


FIGURE D.5.2.2(e) Bladder Tank In-Line Balanced Pressure Proportioning System Setup for Surrogate Liquid Type Test.

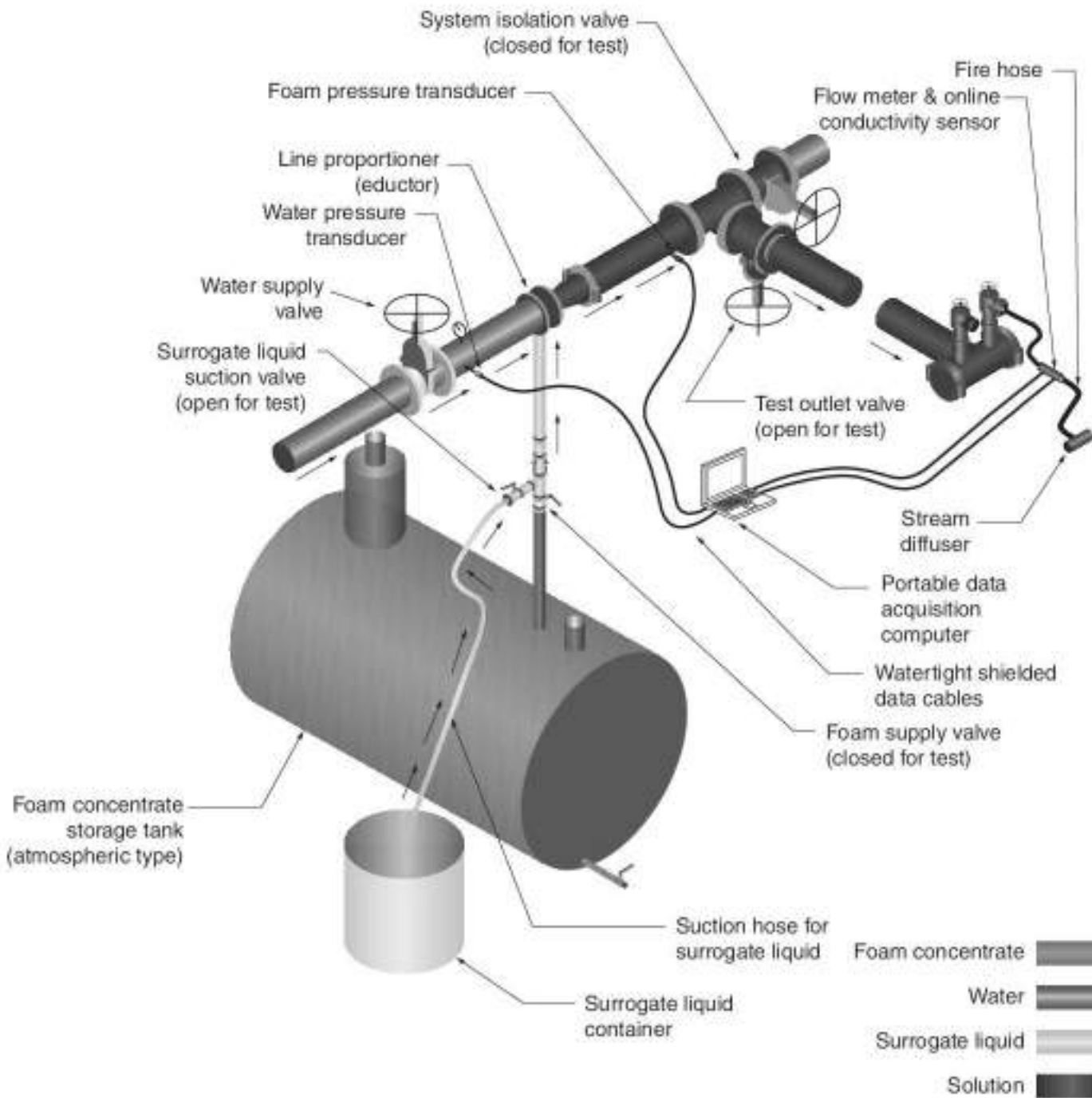


FIGURE D.5.2.2(f) Atmospheric Tank Eductor Proportioning System Setup for Surrogate Liquid Type Test.

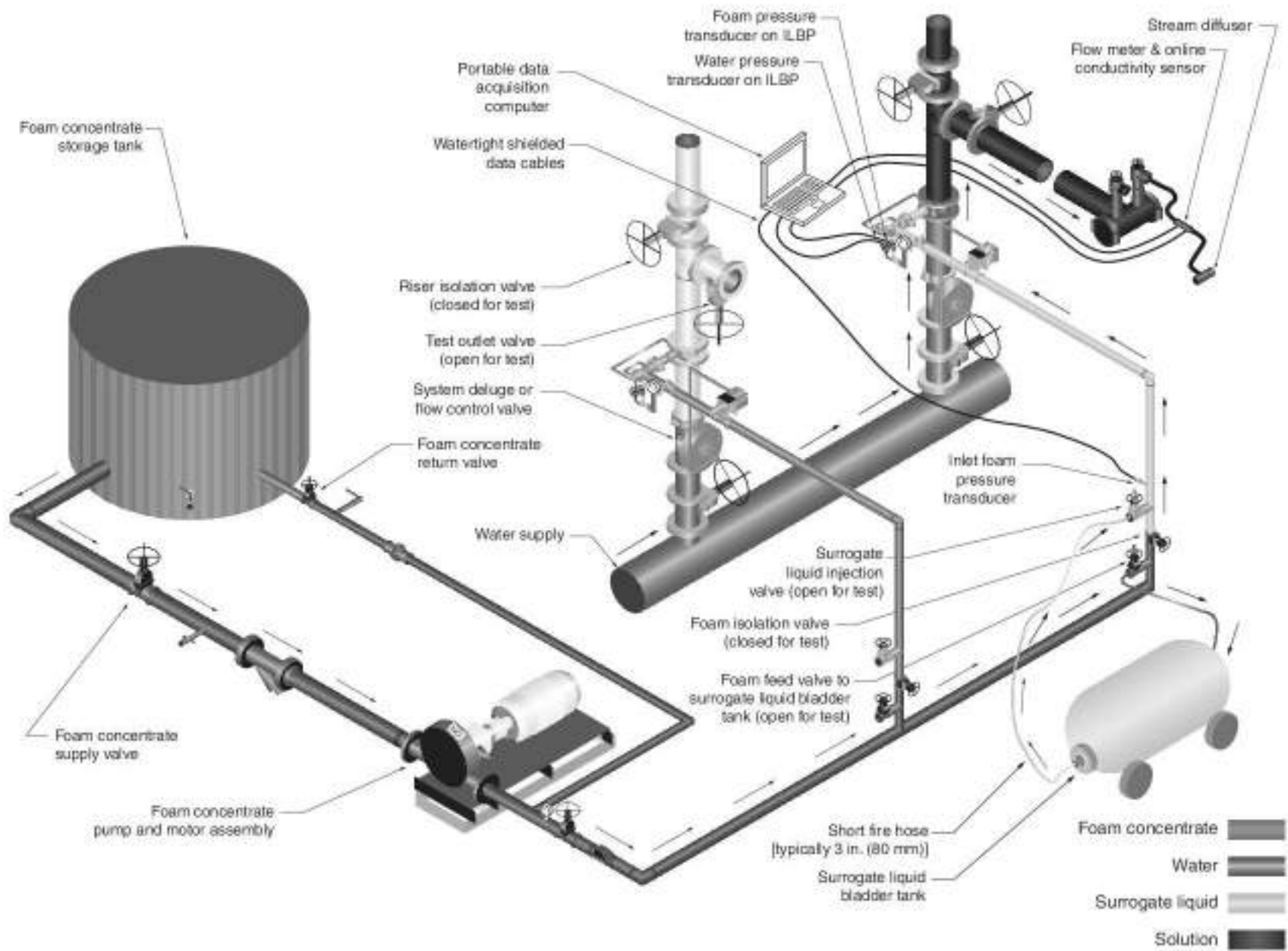


FIGURE D.5.2.2(g) In-Line Balanced Pressure (Pump Type) System Using Surrogate Liquid Method.

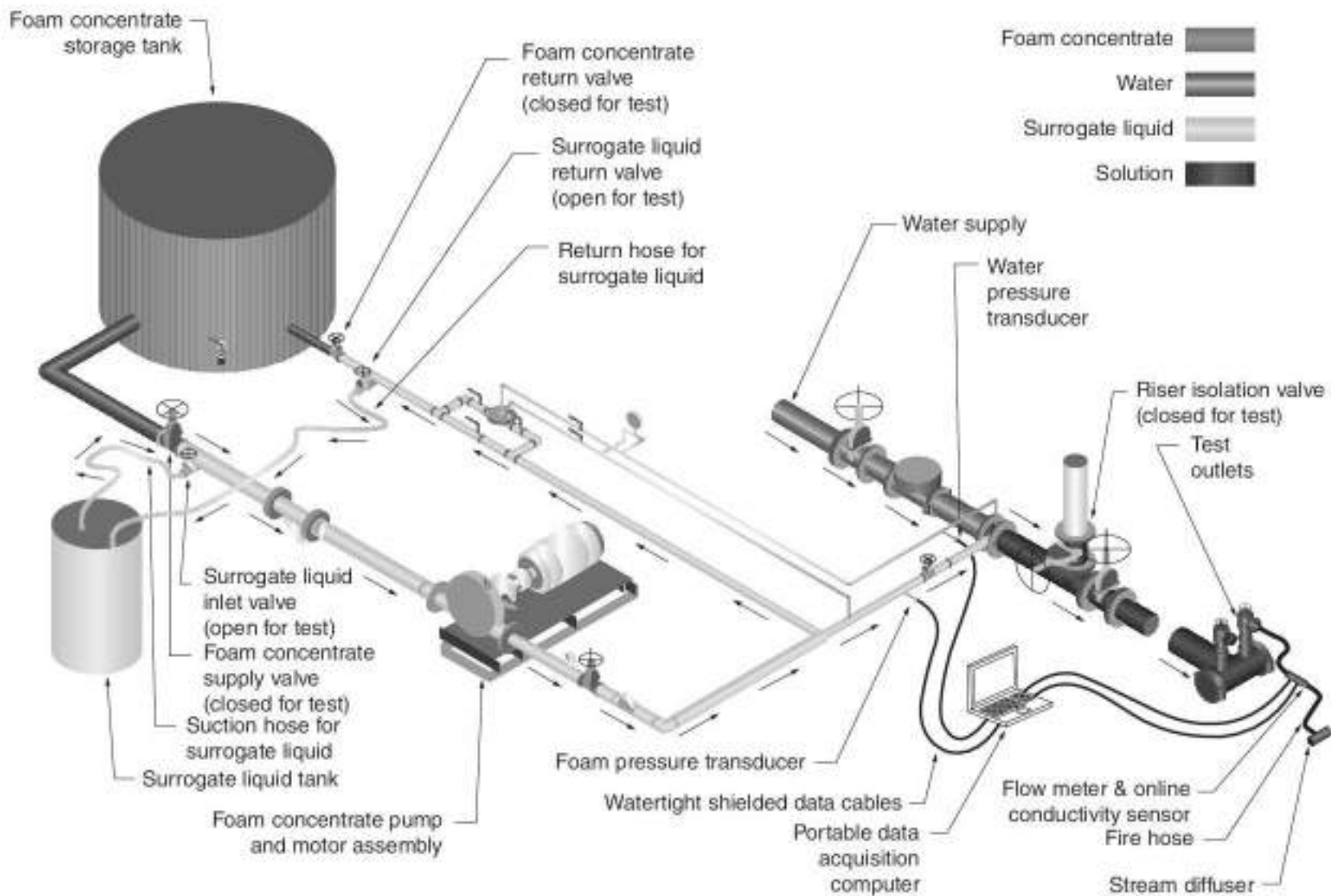


FIGURE D.5.2.2(h) Balanced Pressure Pump System Using Surrogate Liquid Method.

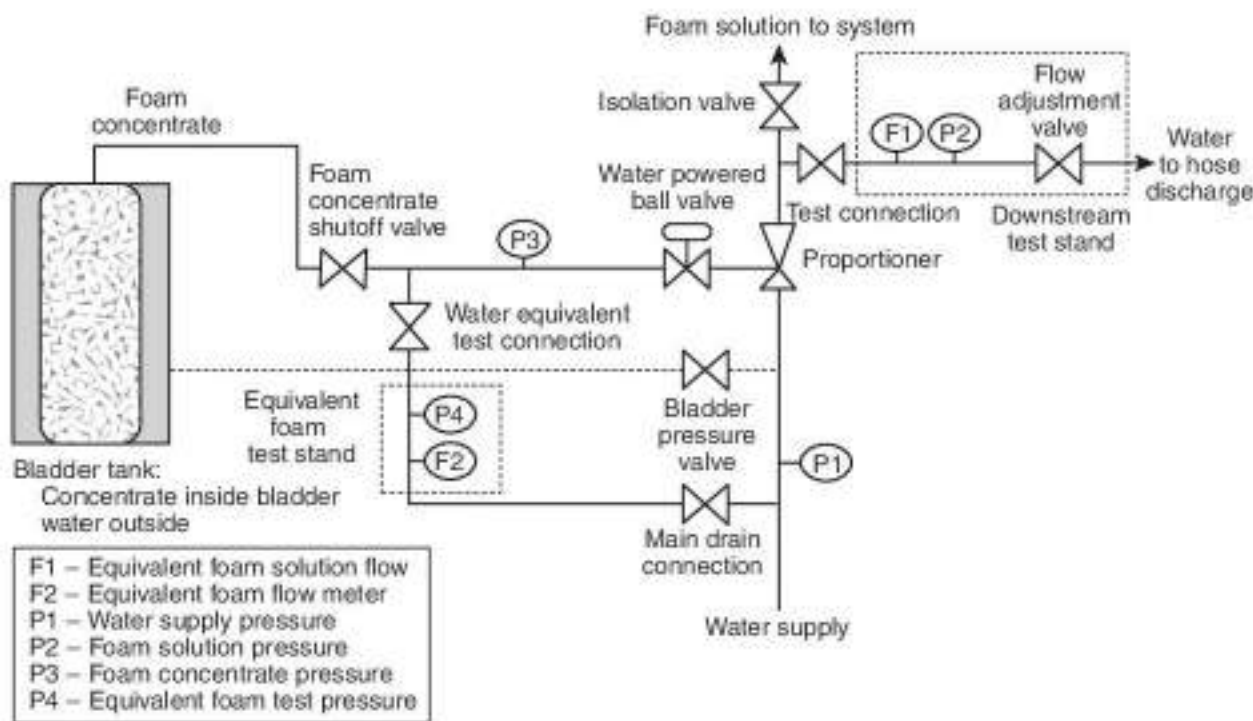
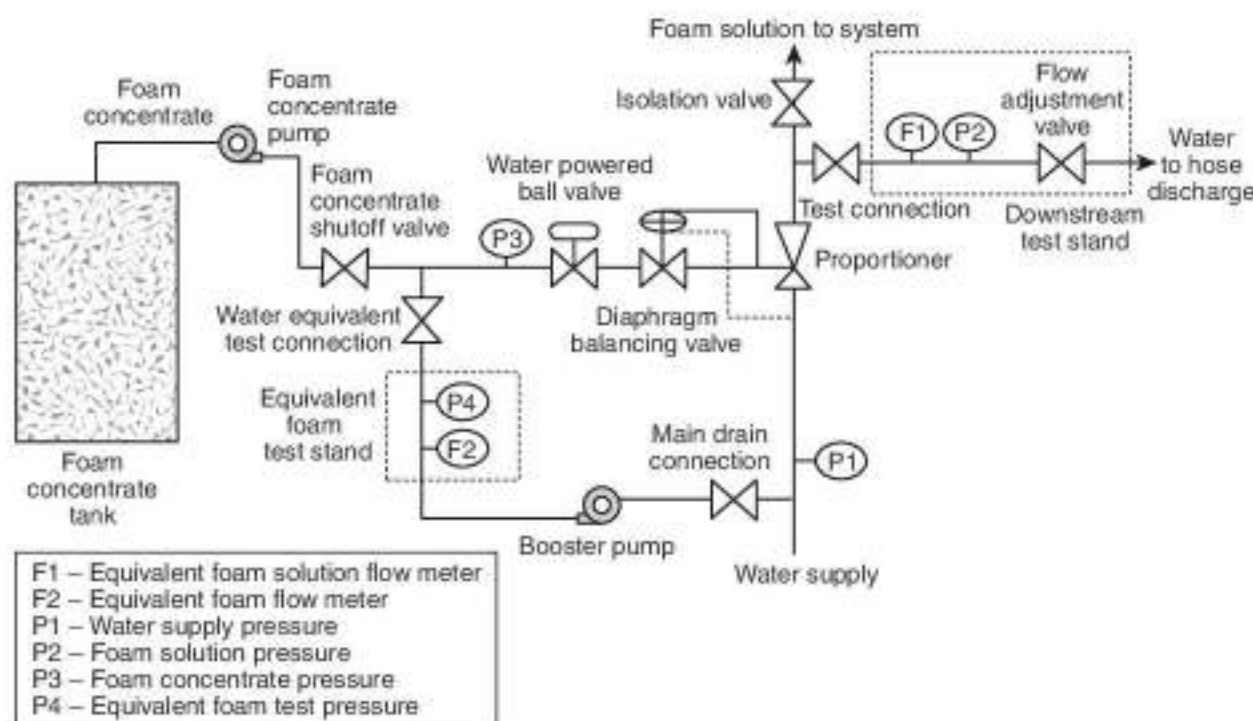


FIGURE D.5.2.3(a) Test Setup Schematic for Initial and Follow-on Water Equivalency Tests with Bladder Tank System.



**FIGURE D.5.2.3(b) Test Setup Schematic for Initial and Follow-on Water Equivalency Tests with Balanced Pressure Valve System.**

### Annex E Foam Health, Safety, and Environmental Issues

*This annex is not a part of the requirements of this NFPA document but is included for informational purposes only.*

**E.1 General.** There has been a significant shift in the emphasis on environmental and health concerns associated with legacy foam products. The purpose of this annex is to provide the foam user community with high-level information and information on the regulatory authorities that are objectively developing suggested solutions to the questions being asked about firefighting foam health, safety, and environmental issues.

In general, the chemicals contained in legacy fluorinated foams, such as AFFF, AR-AFFF, FFFP, etc. (i.e., fluorinated surfactants that are classified as PFAS), have come under significant health and environmental scrutiny.

The approach of dilution and release into the environment and/or wastewater treatment systems is obsolete and unacceptable going forward for all fluorinated foams. International, federal, state, and local jurisdictions are limiting the use of legacy AFFF as a result of these concerns.

US Department of Defense (DoD) and civil aviation authorities are also researching and implementing new restrictions on the use of these legacy products.

Most NFPA standards that cover foam fire suppression agents and systems are being revised to address these new trends and to allow for flexibility going forward.

Currently the criteria for defining an environmentally/toxicologically acceptable alternative is still changing. Once defined, the industry will also need to define the testing and metrics needed to validate the acceptability of such criteria. With that said, there has been a significant shift to the use of synthetic fluorine-free foam (SFFF).

The following are key issues that should be evaluated when using existing legacy fluorinated foams, switching to AFFF C6 foams, or switching to SFFF foams:

- (1) *Firefighter health and safety.* First responder exposure should be minimized using safer work practices and personal protective equipment. In addition, procedures should be developed for rinsing if the foam comes into contact with a person's eyes or skin.
- (2) *Collection of firefighting foam after use.* Industry best practice is that all foams and fire water/foam runoff should be contained, collected, and disposed of based on federal, state, and local requirements and the most current technical information as suggested in the references listed. Foam discharge is more easily handled where there is an in-place collection capability, i.e., primary and secondary containment. This situation might be found in warehouses, tank farms, and firefighting training facilities. Where these facilities are not available, temporary diking is an alternative where time and resources permit. The overall environmental impact of foam discharge requires additional evaluation and development of generally recognized guidance. Until recognized guidance is promulgated, users should rely on manufacturers' data and guidance from policy makers such as the Interstate Technology and Regulatory Council (ITRC) and LAST-FIRE. In all situations, discussions with environmental regulatory authorities are appropriate. Work is continuing to identify appropriate policy and criteria to protect facilities that have typically been protected by foam suppression systems. These efforts are focusing on identifying applicable codes and standards, analyzing environmental impact, evaluating alternatives, and revisiting containment options.
- (3) *Disposal of firefighting foams.* Currently, high-temperature incineration by an accredited environmental firm should be considered the default for disposing of legacy AFFF products (concentrates, solutions, and effluents).

- (4) *Procedures for decontaminating legacy equipment and acceptable levels of cleanliness.* Trying to determine how clean is clean continues to be an issue and might need to be determined based on the regulators' direction or manufacturers' information. Unless equipment is properly cleaned, it might allow the new foam to continue to contaminate the environment. Clean levels might be in the parts per billion to trillion range. Testing and metrics will also need to be defined to validate the level of cleanliness.

The environmental/health concerns associated with these chemicals are challenging for both toxicologists and regulators, requiring continued research and updated regulatory requirements that are still changing. Any users of firefighting foam should research the latest procedures and precautions for their use and disposal prior to placing it into service. The following are two organizations that have developed technically up-to-date and accurate information on this subject.

The ITRC is a state-led coalition working to reduce barriers to the use of innovative air, water, waste, and remediation environmental technologies and processes. ITRC produces documents and training that broaden and deepen technical knowledge and expedite quality regulatory decision making while protecting human health and the environment. With public and private sector members from all 50 states and the District of Columbia, ITRC provides a national perspective. The issues associated with AFFF and the changes in the environmental/use landscape are well documented on the ITRC website <https://pfas-1.itrcweb.org/>

The Office of the Secretary of Defense Strategic Environmental Research and Development Program and Environmental Security Technology Certification Program (SERDP/ESTCP) are funding research for PFAS-free AFFF; detection, fate, and transport of PFAS in the environment; ecotoxicity; and PFAS treatment technologies, including equipment clean out. More information is available at <https://www.serdpestcp.org/Featured-Initiatives/Per-and-Polyfluoroalkyl-Substances-PFASs>

The LASTFIRE Project provided an independent and comprehensive assessment of fire-related risk in large, open-top, floating roof storage tanks resulting in a methodology, by which site-specific fire hazard management policies can be developed and implemented. It, therefore, represents a major advancement in the knowledge about this risk.

The LASTFIRE Foam Position Paper is available at <http://lastfire.org.uk>

**E.2 Discharge Scenarios.** The following are examples of scenarios that might include the use of foam, which are presented here to provide the user with ideas on how to handle these types of situations. The examples are not intended to be complete, as the science on how to handle these scenarios is changing very rapidly. Look at the information provided by ITRC, DoD, and LASTFIRE and sources of current discharge handling approaches. The discharge of a foam-water solution is most likely to be the result of one of the four following scenarios:

- (1) Manual firefighting or fuel-blanketing operations
- (2) Training
- (3) Foam equipment system and foam fire apparatus tests
- (4) Fixed system releases

These four scenarios include events at such places as aircraft facilities, firefighter training facilities, and special hazards facilities (such as flammable/hazardous warehouses, bulk flammable liquid storage facilities, and hazardous waste storage facilities). Each scenario is considered separately in E.2.1 through E.2.4.

**E.2.1 Firefighting Operations.** Fires occur in many locations and under many different circumstances. In some cases, it is possible to collect the foam solution used to douse a fire after it has been put out; and in others, such as in marine firefighting, it is not. These incidents include aircraft rescue and firefighting operations, vehicular fires (i.e., cars, boats, train cars), structural fires involving hazardous materials, and flammable liquid fires. A foam-water solution that has been used in firefighting operations will probably be heavily contaminated with the fuel or fuels involved in the fire. It is also likely to have been diluted with water discharged for cooling purposes.

In some cases, the foam solution used during fire department operations can be collected. However, it is not always possible to control or contain the foam; therefore, a non-persistent foam, such as SFFF, should be considered. This could be a result of the location of the incident, size of the incident, or the circumstances surrounding the incident.

Event-initiated manual containment measures are usually executed by the responding fire department to contain the flow of a foam-water solution when conditions and manpower permit. Those operations include the following measures:

- (1) *Blocking sewer drains.* This is a common practice used to prevent contaminated foam-water solution from entering the sewer system unchecked. It is then diverted to an area suitable for containment.
- (2) *Portable dikes.* These are generally used for land-based operations. They can be set up by fire department personnel during or after extinguishment to collect runoff.
- (3) *Portable booms.* These are used for marine-based operations in the absence of better techniques and are set up to contain foam in a defined area. These operations generally involve the use of floating booms within a natural body of water. The boom contains the foam bubbles, but as the bubbles drain, the foam solution might not be contained and could spread into the rest of the body of water.

**E.2.2 Training.** There are specially designed training foams available from most foam manufacturers that simulate firefighting foam during live training but do not contain fluorosurfactants. These foams are biodegradable, have minimal environmental impact, and can be safely treated at a local wastewater treatment plant. Because they do not contain fluorosurfactants, training foams also have reduced burnback resistance that allows for more repeat fire training sessions. Firefighters and other foam users should work with the authority having jurisdiction (AHJ) to ensure that the use of training foams meets all the local and application-specific live training requirements. In some cases, training foams can also be used as substitutes for legacy fluorinated foams in vehicle and equipment testing.

Training should be conducted under circumstances conducive to the collection of spent foam. Some fire training facilities have elaborate systems designed and constructed to collect foam solution, separate it from the fuel, treat it, and, in some cases, reuse the treated water. At a minimum, most fire training

facilities collect the foam solution for discharge to a wastewater treatment facility. Training can include the use of special training foams or actual firefighting foams. Training facility designs should include containment systems.

Note: The use of fluorinated foams for training is banned in a number of nations and states in the United States.

**E.2.3 System Tests.** Testing primarily involves engineered, fixed foam fire-extinguishing systems. Two types of tests are generally conducted on foam systems: acceptance tests, which are conducted pursuant to installation of the system, and maintenance tests, which are usually conducted annually to ensure the operability of the system.

In the execution of both acceptance and maintenance tests, only a small amount of foam concentrate should be discharged to ensure the correct concentration of foam in the foam-water solution. Designated foam-water test ports can be included in the piping system so that the discharge of foam-water solution could be directed to a controlled location. The controlled location can consist of a portable tank that would be transported to an approved disposal site by a licensed contractor. The remainder of the acceptance test and maintenance test should be conducted using only water.

NEPA 11 explicitly recognizes proportioning test methods that limit or eliminate the need to discharge foam concentrate. These methods are permitted in 12.6.4.

Note the use of fluorinated foams for system testing is banned in a number of nations and states in the United States.

**E.2.4 Fixed System Releases.** This type of release is generally uncontrolled, whether it is the result of a fire incident or a malfunction in the system. The foam solution discharge in this type of scenario can be dealt with via event-initiated operations or engineered containment systems. Event-initiated operations encompass the same temporary measures that would be taken during fire department operations: portable dikes, floating booms, and so forth. Engineered containment is based mainly on the location and type of facility and would consist of holding tanks or areas where the contaminated foam-water solution would be collected, treated, and disposed of properly.

**E.3 Fixed Systems.** Facilities can be divided into those without an engineered containment system and those with an engineered containment system.

**E.3.1 Facilities Without Engineered Containment.** Given the absence of any past requirements for containment, many existing facilities have allowed foam-water solution to flow out of the facility and evaporate into the atmosphere or percolate into the ground. Steps should be taken to avoid this as part of future foam management planning. The choices for containment of foam-water solution at such facilities fall into two categories: event-initiated manual containment measures and installation of engineered containment systems. Selecting the appropriate option depends on the location of the facility, the risk to the environment, the risk of an automatic system discharge, the frequency of automatic system discharges, and any applicable rules or regulations.

Event-initiated manual containment measures are the most likely option for existing facilities without engineered containment systems. This can fall under the responsibility of the responding fire department and include such measures as blocking storm sewers, constructing temporary dikes, and

deploying temporary floating booms. The degree of such measures should be dictated by the facility's location, as well as the available resources and manpower.

The installation of engineered containment systems is an option for existing facilities. There are cases, however, that might warrant the design and installation of such systems.

**E.3.2 Facilities with Engineered Containment.** Any engineered containment system usually includes an oil/water separator. During normal drainage conditions (i.e., no foam solution runoff), the separator functions to remove any fuel particles from drainage water. However, when foam-water solution is flowing, the oil/water separator should be bypassed so that the solution is diverted directly to storage tanks.

The size of the containment system should be dependent on the duration of the foam-water flow, the flow rate, and the maximum anticipated rainfall. Most new containment systems only accommodate individual facilities. However, some containment systems can accommodate multiple facilities depending on the topography of the land and early identification during the overall site planning process.

The specific type of containment system selected should also depend on the location, desired capacity, and function of the facilities in question. The available systems include earthen retention systems, belowground tanks, open-top inground tanks, and sump and pump designs (i.e., lift stations) piped to aboveground or in-ground tanks. Storing spent foam below ground is not advisable due to the potential for leaks. Regular checks can reduce the risk of leaks, but even a small leak over time could result in contaminated soil.

The earthen retention designs consist of open-top earthen berms, which usually rely on gravity-fed drainage piping from a protected facility. They allow the foam-water solution to be collected in an impermeable liner. Legacy foams should not be contained using earthen retention, as the soil can become contaminated.

Closed-top, belowground storage tanks usually consist of a gravity-fed piping arrangement and can be suction pumped out.

Open-top, belowground storage tanks are usually lined concrete tanks that can rely on gravity-fed drainage piping or a sump and pump arrangement. These can accommodate individual or multiple facilities. They must also accommodate the maximum anticipated rainfall.

Aboveground tanks incorporate a sump and pump arrangement to closed, aboveground tanks. Such designs usually incorporate the use of one or more submersible or vertical shaft large-capacity pumps. These can accommodate individual or multiple facilities.

**E.3.3 New Facilities.** The decision to design and install a fixed foam-water solution containment system is dependent on the location of the facility, the risk to the environment, the possible impairment of facility operations, the design of the fixed foam system (i.e., automatically or manually activated), the ability of the responding fire department to execute event-initiated containment measures, and any pertinent regulations.

Where conditions warrant the installation of engineered containment systems, there are a number of considerations. They include the size of the containment system, the design and type of containment system, and the capability of the

containment system to handle individual or multiple facilities. Engineered containment systems can be used where foam extinguishing systems are installed in facilities that are immediately adjacent to a natural body of water. These systems might also be prudent at new facilities, where site conditions permit, to avoid impairment of facility operations.

#### Annex F Test Method for Marine Firefighting Foam Concentrates Protecting Hydrocarbon Hazards

*This annex is not a part of the requirements of this NFPA document but is included for informational purposes only.*

**F.1 Introduction.** The following test method has been specifically developed for use in demanding marine applications. It is derived from Federal Specification O-F-555C, which is no longer in print. It specifically incorporates a large surface area of 100 ft<sup>2</sup> (9 m<sup>2</sup>), sealability testing, and a burnback test conducted 15 minutes after fire extinction. The test method given here incorporates a high freeboard that is subject to high temperatures; both conditions add to the difficulty of this test method. This test method uses gasoline, a highly challenging test fuel, and requires that fresh fuel be used for each test. This test utilizes a square pan. The geometry of the pan's corners better simulates the complex steel shapes found in ships' cargo holds and bilges than round fire test pans used in other test methods. The test method employs a fixed nozzle, thus removing any bias caused by an operator applying foam at the test facility.

**F.2 Test Facility.** The test should be conducted at a test facility acceptable to the AHJ.

#### F.3 Test Apparatus.

**F.3.1 Pan.** The test pan should be of 10-gauge steel minimum construction measuring 10 ft (3 m) long x 10 ft (3 m) wide x 3 ft (0.9 m) deep. The sides of the pan should be properly reinforced to prevent warpage due to heat generated during the test.

**F.3.2 Nozzle.** The test nozzle should be as shown in Figure F.3.2. Alternate nozzles should be approved by the AHJ. The nozzle should flow 6.0 gpm (23 L/min) at 100 psi (69 bar) inlet pressure.

**F.3.3 Fuel.** A minimum of 75 gal (284 L) of gasoline is needed to be floated on a sufficient quantity of potable water so that the fuel surface is 24 in. (600 mm) below the top edge of the tank. For each succeeding test the pan should be completely emptied of the fuel and foam residue from the previous test. The gasoline should be commercial unleaded regular motor fuel with an octane rating between 82 and 93 per Federal Specification VV-G-1690. The fuel temperature should be not less than 70°F (21°C). An alternate test fuel can be used provided that it has properties equivalent to the unleaded fuel specified above and has been approved by the AHJ.

**F.3.4 Synthetic Sea Water.** The composition should be as described in ASTM D1141.

#### F.3.5 Conversion Factors.

$$1 \text{ L/min}\cdot\text{m}^2 = 0.0245 \text{ gpm/ft}^2$$

$$6 \text{ L/min}\cdot\text{m}^2 = 0.147 \text{ gpm/ft}^2$$

$$3 \text{ L/min}\cdot\text{m}^2 = 0.0735 \text{ gpm/ft}^2$$

$$1 \text{ gpm/ft}^2 = 40.7 \text{ L/min}\cdot\text{m}^2$$

$$0.24 \text{ gpm/ft}^2 = 9.77 \text{ L/min}\cdot\text{m}^2$$

#### F.4 Test Procedure.

**F.4.1 Fire Extinguishment.** Foam concentrate should be subjected to four consecutive fire tests by discharging through a 6 gpm (23 L/min) nozzle at an inlet gauge pressure maintained at 100 psi (688.5 kPa)  $\pm$  2 psi (13.8 kPa), and a water temperature of 68  $\pm$  8°F (20  $\pm$  5°C). The concentrate should be at approximately the same temperature as the water. Two of the tests should be conducted with freshwater, and two of the tests should be conducted with salt water as described in Section F.3.4. The foam liquid solution should be premixed and applied at a rate of 3.0 percent by volume for 3 percent foams, 6.0 percent for 6 percent foams, and so forth. The nozzle should be positioned in the middle of one side of the test pan with the nozzle tip 16 in. (400 mm) directly above the top edge of the test pan. The fire should be permitted to burn freely for 60 seconds before foam application. The foam should be directed across the fire to strike the approximate center of the back side of the pan, 12 in. (300 mm) above the fuel level and should be applied for a 5-minute period. (If prior to the test, foam is discharged into the pan to align the nozzle for proper foam stream impact position on the back side of the pan, such foam should be removed from the pan prior to the test.) The following procedures should take place:

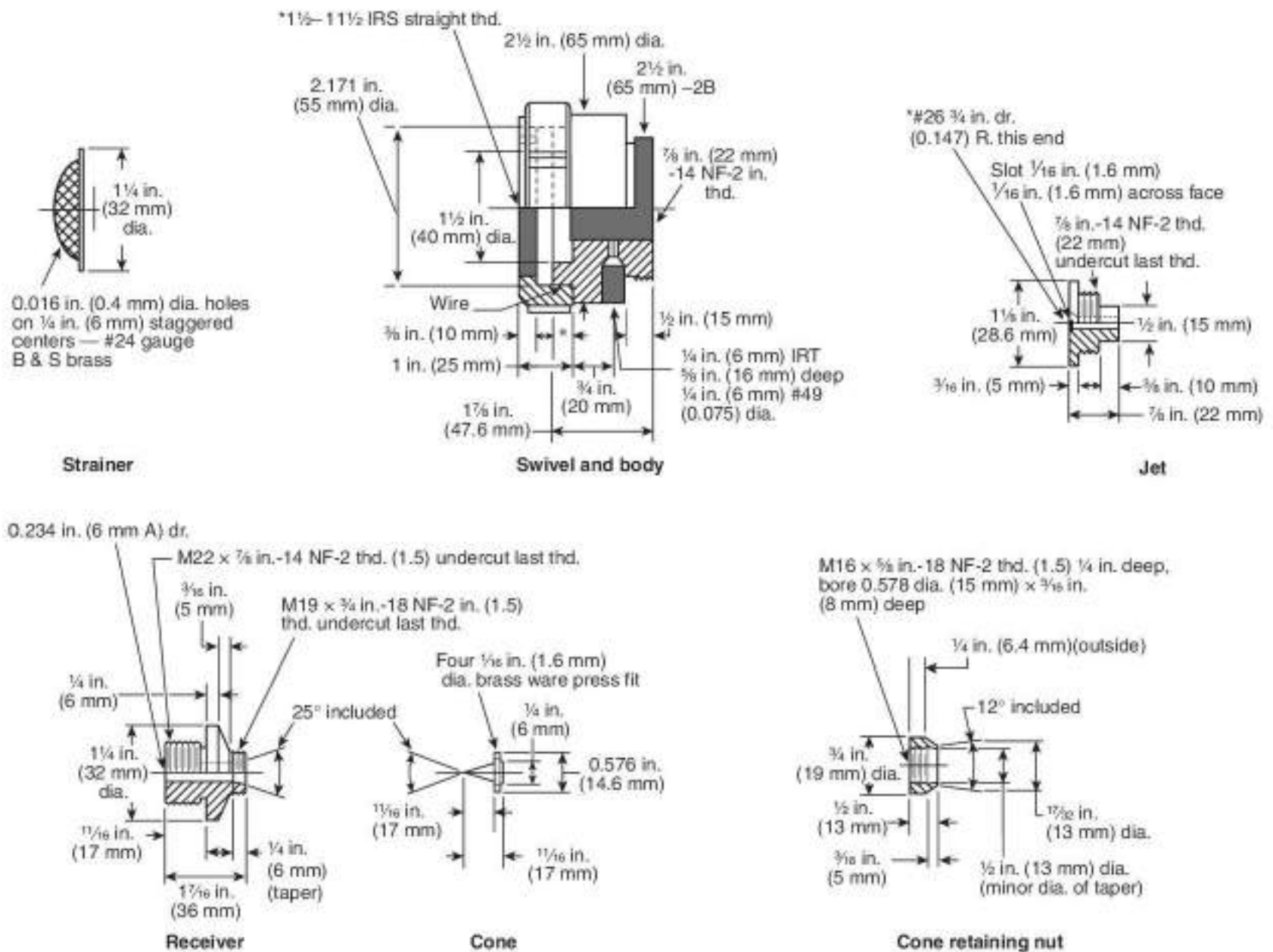
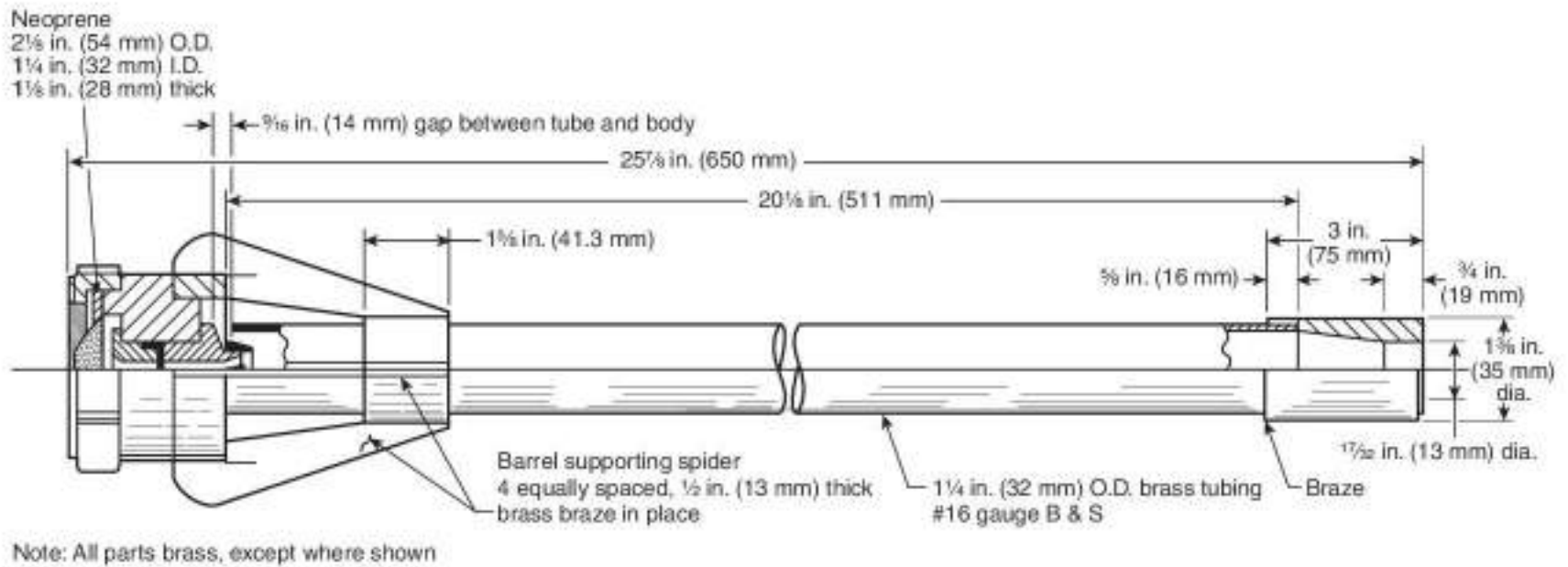
- (1) Observations. Observations and records are as follows:
  - (a) Record the period required, after start of foam application, for the foam to spread over the fuel surface as "coverage" time.
  - (b) Record the period for the fire to be extinguished except for licks of flame at the edges of the foam blanket as "control" time.
  - (c) Record the period for complete extinguishment as "extinguishment" time.
- (2) Record. Record the name of the manufacturer, foam type, trade name, batch number, and date of manufacture.

**F.4.2 Sealability.** A lighted torch should be passed continuously over the foam blanket starting 10 minutes after the end of foam discharge. Fourteen minutes after completion of foam application, the lighted torch should be applied over the foam blanket for 1 minute with the torch touching the foam blanket but not penetrating the foam blanket by more than 1/2 in. (13 mm). The torch should touch the blanket at least every 24 in. (600 mm) along the sides of the test pan, at points where the foam blanket appears significantly less than the average thickness, in all four corners of the pan, and at random points in the main area of the pan. However, the torch should not be dragged through the foam.

**F.4.3 Burnback.** One of the methods described in F.4.3.1 and F.4.3.2 should be used.

**F.4.3.1 Method 1.** Fifteen minutes after completion of the foam application, an opening 36 in.<sup>2</sup> (23,220 mm<sup>2</sup>) should be made in the foam blanket approximately 24 in. (600 mm) from the side of the pan. The exposed fuel should be reignited with a torch and permitted to burn for 5 minutes. After the 5-minute burning period, the area involved in flames should be determined.





\*Metric conversion not available.

FIGURE F.3.2 Test Nozzle.

**F.4.3.2 Method 2.** As an alternative to Method 1, two 12 in. (300 mm) diameter stove pipes should be placed in the foam blanket during the sealability test, at least 24 in. (600 mm) from the sides of the pan, and the foam inside the stove pipes should be removed. At 15 minutes after the end of the foam discharge, the exposed fuel inside the stove pipes should be ignited by torch and permitted to burn for 1 minute. The first stove pipe should then be removed. After an additional 4-minute burning period, the area involved in flames should be determined. If, upon removal of the pipe, foam covers the exposed fuel area and extinguishes the fire, the fuel inside the second stove pipe should be ignited and allowed to burn freely for 1 minute. The second stove pipe should then be removed, and the area involved at 20 minutes after the end of foam discharge should be determined. If, upon removal of the second pipe, the foam again covers the exposed fuel and extinguishes the fire, no further burnback tests are necessary.

### F.5 Acceptance Criteria.

**F.5.1 Fire Performance.** The foam as received should have a coverage time of not more than 2 minutes, a control time of not more than 5 minutes, and complete fire extinguishment in not more than 5 minutes after start of foam application.

**F.5.2 Sealability.** The foam blanket should protect the fuel below the foam from reignition by a lighted torch for a period of not less than 15 minutes after the end of foam application. Any ignition of fuel vapors above the foam blanket should result in complete self-extinguishment prior to the end of the test period. Record in detail the type, location, and duration of any burning observed.

### F.5.3 Burnback.

**F.5.3.1 Method 1.** The foam blanket should prevent the spread of fire beyond an area approximately 2.7 ft<sup>2</sup> (0.25 m<sup>2</sup>).

**F.5.3.2 Method 2.** The area involved in flames should not exceed 2.7 ft<sup>2</sup> (0.25 m<sup>2</sup>).

**F.6 Foam Quality.** Foam quality tests should be conducted using the same batch of premix as used during the fire tests. Foam expansion and 25 percent drainage tests should be performed as explained in Annex D.

**F.7 Procedures in Case of Failure.** Four consecutive successful tests are recommended. Failure of any one test will result in another series of four consecutive tests being performed successfully.

## Annex G Foam Concentrate Quality

*This annex is not a part of the requirements of this NFPA document but is included for informational purposes only.*

**G.1 Fire Performance Test for Class A Materials.** Suitable tests based on fire performance on Class A fires with a flammable liquid accelerant, performance on Class B fires, and performance on liquefied natural gas (LNG) fires are described in this annex. The purpose of this test is to provide a reproducible Class A fire situation where foam is required to move a substantial distance at a slow rate to work the fire. The time to move this distance and to fill to the top of the test combustibles is the foam transit time. The effect of the transit time is to give age to the foam during the period of its slow movement from foam generator to fire.

The test should be conducted in an open-top pen or building of suitable construction and suitable dimensions. To prevent the velocity of foam movement from being too high, the width of the pen or building times 100 should give a figure not smaller than the capacity in cubic feet per minute of the foam generator used in the test. The height of the sides of the pen or building should be about 10 ft (3 m). If the fluidity of the foam permits, the height can be less. However, the foam should neither flow over the sides of the pen nor contact the ceiling of the building during the test. The foam generator should be set at one end of the pen or building, and the fire should be set 10 ft (3 m) from the opposite end. The distance between the foam generator and the fire should be as required to give the desired foam transit time. (See Figure G.1.)

Foam should be produced by a generator in which the expansion ratio is approximately that produced by the generator proposed for installation.

The test fire should be made with a stack of eight standard 4 ft × 4 ft (1.2 m × 1.2 m) hardwood pallets dried to a moisture content between 5 and 8 percent, set on suitable noncombustible supports not more than 24 in. (600 mm) above the floor. Beneath the pallets should be a 10 ft<sup>2</sup> (0.93 m<sup>2</sup>) pan containing 1 gal (3.8 L) of heptane or naphtha floating on water. The surface of the flammable liquid should be approximately 12 in. (300 mm) below the bottom boards of the bottom pallet.

The first test of each series should be a timed fill without a fire to determine the foam transit time. The location of the leading edge of the foam as it progresses across the floor of the pen or building should be timed at suitable intervals. Also, the time should be noted when the foam reaches the edge of the pan. This data will permit estimating, with reasonable accuracy, the location of the leading edge of the foam 3 minutes before the foam reaches the edge of the pan. Thereafter, during each fire test, the heptane should be ignited when the foam reaches that point corresponding to 3 minutes in advance of reaching the pan. In this manner, the fire is given a reproducible 3-minute preburn. This fill test can be terminated when the foam has filled to the top of the wood pallets and the foam transit time has been determined.

The minimum foam transit time should be 12 minutes (150 percent of the maximum submergence time of 8 minutes, from Table 7.12.7.1). To be considered successful under the foam transit time condition, the foam should give adequate control of the test fire. The foam generator should be run for a maximum of 30 minutes. Adequate control should be interpreted as the absence of active burning within the test stack while the stack is covered with foam.

**G.2 Quality Control Test.** The air and solution temperatures are to be maintained between 60°F and 65°F (15.6°C and 18.3°C). The laboratory scale expansion and drainage test described in the following list has been found suitable for quality control purposes:

- (1) Mix foam solution.
- (2) Fill foam solution can with solution.
- (3) Weigh foam solution can and thread onto apparatus.
- (4) Apply 25 psi (172 kPa) air pressure to liquid.
- (5) Start blower and adjust damper to approximately  $\frac{1}{2}$  opening. (The damper might have to be adjusted later in order for the desired expansion ratio to be obtained.)

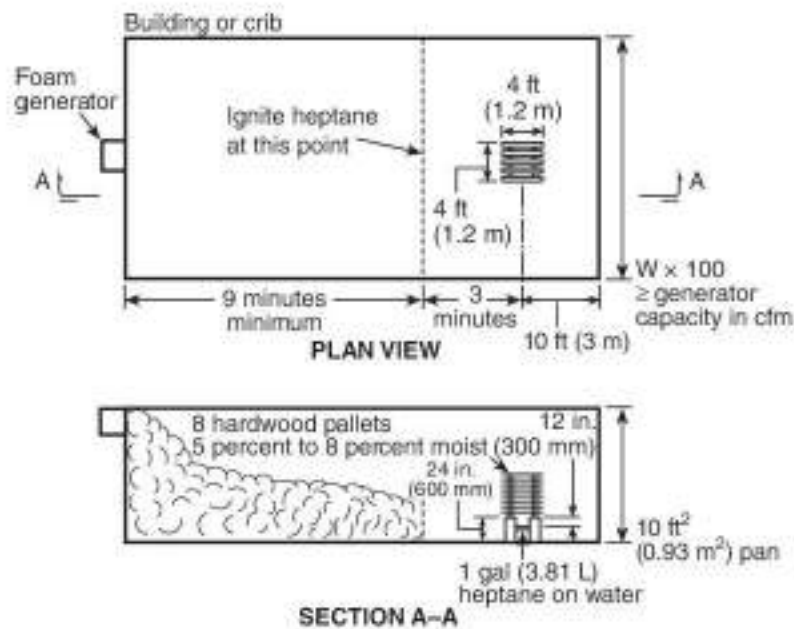


FIGURE G.1 Fire Performance Test.

- (6) Open solenoid. Adjust liquid pressure to 15 psi (103 kPa) using liquid metering valve. (Later readjustment might be necessary.)
- (7) As foam forms at screen, catch first droplets in beaker. Keep liquid in beaker to add to residue in foam can.
- (8) Allow drainage drum to fill with expanded foam. Start timer and shut off solenoid when drum is full.
- (9) Add liquid from step 7 to foam solution can and weigh again. Record total milliliters used. (1 g is approximately 1 mL.)
- (10) Record liquid drainage in milliliters at 1-minute intervals for 5 minutes, then at 10-minute intervals.
- (11) Plot time versus percent drained and record expansion ratio.

[G.2a]

$$\text{Percent drained} = \frac{\text{Total mL drained to given time} \times 100}{\text{Total mL used}}$$

[G.2b]

$$\text{Expansion ratio} = \frac{\text{Drum volume mL}}{\text{Total mL used}}$$

See Figure G.2(a) and Figure G.2(b).

**G.3 Fire Performance Test for Class B Materials.** The purpose of this test is to provide a reproducible Class B fire situation where foam is required to move a substantial distance at a slow rate toward the fire. The time to move this distance and to fill to the top of the test pan is the foam transit time. The effect of the transit time is to give age to the foam during the period of its slow movement from foam generator to fire. The test should be conducted in an open-top pen or building of suitable construction and suitable dimensions. To prevent the velocity of foam movement from being too high, the width of the pen or building times 100 gives a figure not smaller than the capacity in cubic feet per minute of the foam generator used in the test. The height of the sides of the pen or building should be 10 ft (3 m). If the fluidity of the foam permits, the height can be less. However, the foam must neither flow over

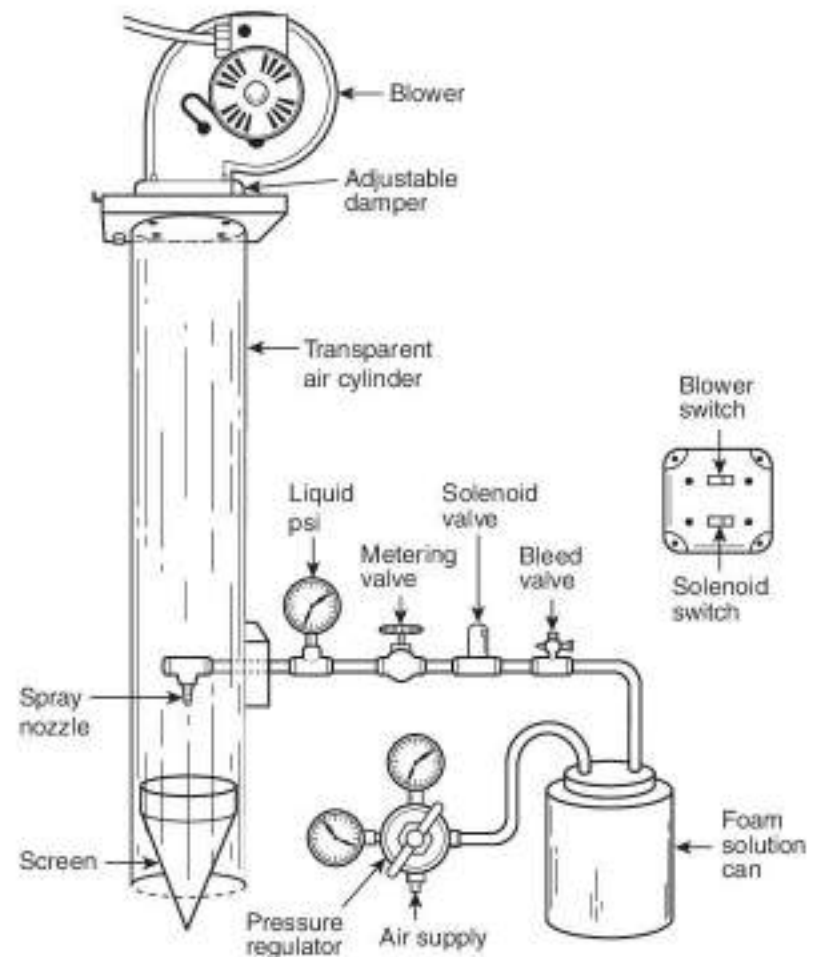
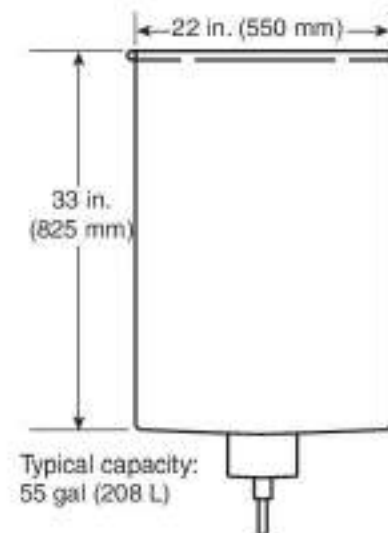


FIGURE G.2(a) High-Expansion Foam Quality Test Generator.



Note: Drum dimensions can vary  $\pm 5$  percent from the typical values shown.

FIGURE G.2(b) Typical Drainage Drum for High-Expansion Foam Expansion and Drainage Test.

the sides of the pen nor contact the ceiling of the building during the test. The foam generator should be set at one end of the pen or building, and the fire should be 10 ft (3 m) from the opposite end. The distance between the foam generator and the fire is as required to give the desired foam transit time. Foam should be produced by a generator in which the expansion ratio is approximately equal to that produced by the generator for installation.

Flammable liquid fire tests are conducted using a 50 ft<sup>2</sup> (4.6 m<sup>2</sup>) steel pan, square in shape, and 12 in. (300 mm) in depth, filled with a 2 in. (50 mm) layer of *n*-heptane and a 4 in. (100 mm) layer of water to obtain a freeboard of 6 in. (150 mm). The test pan is located on the floor.

The fuel is ignited and foam discharge is started to allow the fuel to burn for approximately 1 minute before the foam reaches the top edge of the pan. Observations as to transit time and whether or not the fire is extinguished are made.

The minimum foam transit time is 7.5 minutes. To be considered successful under the foam transit time condition, the foam must extinguish the test fire. The foam generator can be run for a maximum of 15 minutes.

The results of these tests should be recorded in the format illustrated in Table G.3.

**G.4 Standard Evaluation Test of High-Expansion Foam Systems for LNG Fires.** The purpose of this standard test is to evaluate the effectiveness of high-expansion foam systems applied to LNG fires for fire control.

Definitions are as follows:

- (1) *Fire control time* is the elapsed time from the beginning of foam application until the average radiation levels, 1½ pool widths from the pool center measured in the cross-wind direction, have reached 10 percent of the initial steady-state uncontrolled values.
- (2) *Foam discharge rate per unit area* is the expanded foam flow rate in cubic feet per minute per square foot of LNG surface area.

Test equipment is as follows:

- (1) A test pit configured as shown in Figure G.4
- (2) Four wide-angle, water-cooled radiometers with continual recording instruments for each
- (3) Weather instruments for measuring temperature and relative humidity and measuring and recording wind velocity and direction during the tests
- (4) Stopwatches
- (5) Calibrated equipment for measuring water and foam concentrate flows or foam solution flows if premixed
- (6) A foam generator calibrated to determine its performance curve of water pressure, output, expansion ratio, and expanded foam drainage rate

Test procedure is as follows:

- (1) All test instrumentation must be checked or calibrated prior to conducting the tests.
- (2) The foam solution rate, foam concentrate proportioning ratio or total solution flow rate if the solution is

premixed, and foam generator inlet solution pressure as specified by the equipment manufacturer should be set and maintained throughout the test.

- (3) Radiometers should be positioned as shown in Figure G.4.
- (4) As shown in Figure G.4, a single foam generator should be centered along the upwind side of the pool. A single foam application rate must be established and cannot be changed after ignition. All foam generated should be applied to the test pit. The control time will commence at the time of first visible foam at the application point.
- (5) The water flow and foam concentrate flow, or the solution flow, if premixed, should be monitored and recorded to ensure proper proportioning and application rates.
- (6) At the start of the test, the wind should be not more than 9 knots (10 mph or 16 km/hr) with maximum gusts to 13 knots (15 mph or 24 km/hr). For optimum test conditions with minimum LNG vaporization, standing water should not be in the pit.
- (7) At least 5 gal/ft<sup>2</sup> (204 L/m<sup>2</sup>) of LNG, with a storage temperature not warmer than -240°F (-151°C) and an analysis of at least 85 percent methane, should be discharged into the pit. The first ignition of the pit must occur within 30 minutes of the beginning of discharge.
- (8) After ignition, there must be a preburn until the fire stabilizes as indicated by the radiometers, but not longer than 45 seconds.
- (9) Foam application should commence, and the fire control time should be measured.
- (10) Once control is established, the discharge rate per unit area for maintenance of fire control should be determined by shutting off the foam and allowing the fire to build up to 25 percent of initial intensity, then reapplying the foam until radiation levels are reduced to 10 percent of the initial uncontrolled intensity. A minimum of three cycles should be repeated.

Data in the test report includes the following:

- (1) Date and time of tests
- (2) Location of tests
- (3) Testing agency
- (4) Model of equipment and materials tested
- (5) Temperature, relative humidity, wind speed and direction, water temperature and quality (potable or nonpotable and fresh or salt), and general weather conditions for each test
- (6) Initial LNG analysis before discharge into pit
- (7) Depth of LNG in pit
- (8) Foam generator performance data
- (9) Data for all recording and measuring devices

**Table G.3 Foam Type Test Report Format**

Test No.	Fire Type	Time Generator Started After Ignition		Time to Cover Pan		Inlet Pressure (psi)	No Visible Flame		Fire Control		Fire Extinguished		Generator Off	
		Min	Sec	Min	Sec		Min	Sec	Min	Sec	Min	Sec	Min	Sec
—	—	—	—	—	—	—	—	—	—	—	—	—	—	—
—	—	—	—	—	—	—	—	—	—	—	—	—	—	—

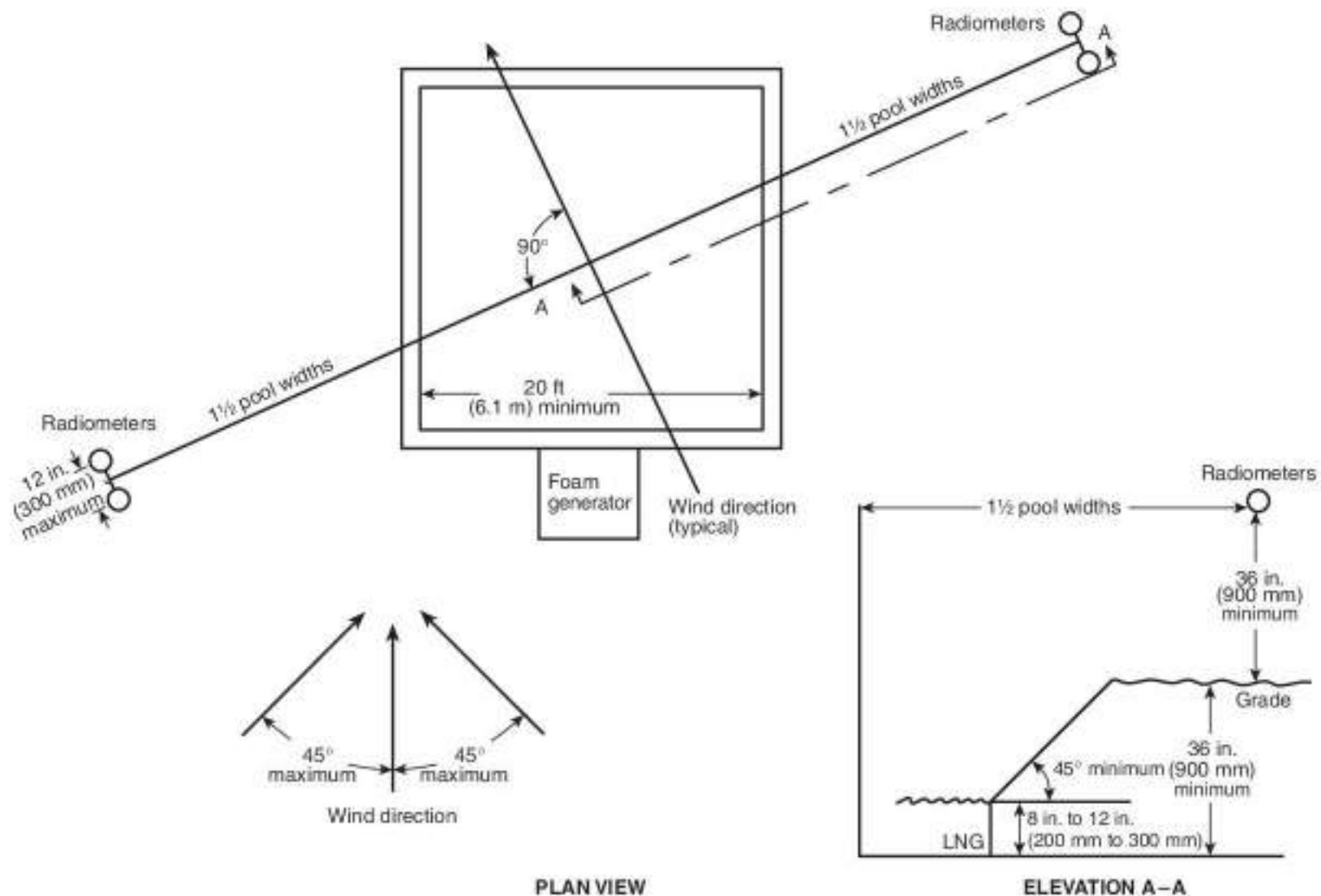


FIGURE G.4 High-Expansion Foam Standard Evaluation Test Pit.

- (10) Pit dimensions, orientation, and test setup
- (11) Application rates, expansion ratios, and supporting measurements
- (12) Curve showing time versus radiation levels, marked to show control times and beginning and end of foam application for each test

#### Annex H Synthetic Fluorine-Free Foam (SFFF) Research Testing Summary

*This annex is not a part of the requirements of this NFPA document but is included for informational purposes only.*

**H.1 Overview.** Extensive testing has been done and additional testing is expected as different manufacturers and research organizations develop the next generation of fluorine-free firefighting foam for hydrocarbon/polar solvent fires. Testing has been conducted by the following three types of organizations:

- (1) Foam manufacturers and research organizations
- (2) User organizations or research organizations for those users such as LASTFIRE
- (3) Research or standard writing organizations such as the Fire Protection Research Foundation (FPRF), FM Approvals, and Underwriters Laboratories, Inc.

**H.1.1** Annex H covers testing conducted by two independent research organizations — LASTFIRE and the FPRF — to better understand the use of fluorine-free foams (FFFs) in extinguishing Class B flammable liquid fires.

Many of the application characteristics of synthetic fluorine free foam (SFFF) are the same or similar to the application characteristics of protein foam, the major firefighting foam prior to the introduction of aqueous film forming foams (AFFF). Both work by applying bubbles of foam on the fire.

**H.1.2** Following is a summary of researchers' findings so far and the key differences between AFFF and SFFF. More research is needed, not only about the properties of the existing FFFs, but also for the still-to-be-introduced alternative foam agents and their properties.

- (1) Drop-in replacements for AFFF and the common properties of each type of foam:

**AFFF:** Generally, listed AFFFs today have common properties and can be used interchangeably in proportioning and application systems with only minor change-out requirements (most manufacturers do not recommend mixing different AFFF, but this is done during emergency situations). Because their foam quality properties are common, one listed AFFF is a drop-in replacement for another listed AFFF.

**SFFF:** Generally, listed SFFFs today do not have common properties and cannot be used interchangeably in proportioning and application systems without first ensuring they will operate in AFFF equipment. Presently, there is no drop-in replacement SFFF for AFFF. The equipment would require reassessment to ensure that the proportioning and application nozzles operate correctly with the new foam. As in the early days of AFFFs, each SFFF is unique and cannot be used interchangeably with other SFFFs — they might not have the same density or viscosity properties. Users must work with foam suppliers to ensure the SFFFs and proportioning and application equipment work together.

(2) Foam blanket versus foam blanket and foam film:

**AFFF:** As the name implies, AFFFs, when properly applied, provide both a blanket of foam solution and air bubbles that flows across the fuel and a film that flows from the bubbles to quickly cover the fuel surface. This characteristic makes AFFF especially useful in aircraft fire and rescue situations.

**SFFF:** SFFF, when properly applied, provides a blanket of foam solution and air bubbles that flows across the fuel. This foam does not produce a film agent.

(3) Foam drain time:

**AFFF:** Drain time is relatively short — 10 to 15 minutes. This allows the foam bubbles to refresh the film, but the foam blanket/bubbles must be reapplied often. If the AFFF is being used for vapor suppression over a long period of time, a significant amount of foam concentrate is needed for AFFF reapplication.

**SFFF:** When properly applied, SFFF produces a blanket of foam that is robust and stays in the mixture longer — 30 minutes to several hours depending on how it is applied. This allows for less frequent reapplication than AFFF and results in lower foam concentrate use when SFFF is employed for vapor suppression.

(4) Aspiration rate of the foam:

**AFFF:** Presently, most AFFFs are applied using non-air-aspirating nozzles, whether by fixed equipment, handline, or master stream application. This results in an air-aspiration ratio of between 3 to 5 times foam solution to air aspiration. For many reasons, this has worked successfully for AFFFs, but the addition of the film to assist the foam in extinguishing the fire is the most important one.

**SFFF:** SFFFs presently available appear to work much better on extinguishing Class B fires when applied using an air-aspirated nozzle, whether fixed equipment, handline, or master stream. This results in an air-aspiration ratio of at least 7 to 10 times foam solution to air aspiration. The SFFFs being tested at this time also appear to work much better when applied using compressed air foam technology with its more uniform bubble configuration.

Based on previous experience with protein foam, higher air-aspiration ratios in the 10 to 20 range could produce even more robust SFFFs.

(5) Foam application range:

**AFFF:** Most AFFFs are applied using a nozzle that is not specifically designed to air-aspirate the foam. These AFFFs have a more concentrated liquid finished foam

and, when applied, tend to have an application footprint similar to a water-only application. Chapter 5 requires the application rate to be increased by 50 percent to compensate for the impact of wind and foam drop-out. Large master stream non-air-aspirated appliances are available that can deliver non-air-aspirated foam up to 400 ft to 500 ft (120 m to 150 m) effectively.

**SFFF:** When properly applied using handline and master stream nozzles, SFFFs should have a higher air-aspiration ratio and will not travel as far as a similar water stream application. Chapter 5 requires the application rate to be increased by 50 percent to compensate for the impact of wind and foam drop-out — a concept originally developed for protein-based foam. Large master stream air-aspirated appliances are available that can deliver air-aspirated foam up to 350 ft to 400 ft (105 m to 120 m) effectively.

## H.2 Testing Conducted by the Fire Protection Research Foundation (FPRF).

**H.2.1 General.** To provide data and guidance for foam system application standards, the FPRF contracted Jensen Hughes and the Naval Research Laboratory (NRL) to conduct an experimental program to assess the firefighting capabilities of fluorine-free, Class B firefighting foams on fires involving hydrocarbon and alcohol-based fuels. The objectives of this study were to determine the fire extinguishment and burnback times for five FFFs and one short-chain C6 AFFF formulation (for baseline) as a function of application rate (gpm/ft<sup>2</sup>) and foam discharge density (gal/ft<sup>3</sup>) for a range of test parameters, including foam quality and aspiration, fuel type, water type, and fuel temperature. The complete report is available at the FPRF website.

**H.2.2 Report Summary.** The assessment was conducted as a blind study. The foams were given generic names, and the manufacturers were not identified. The experimental approach consisted of conducting a parametric assessment of the critical variables that could affect the fire protection performance of new foam formulations using UL 162, *Foam Equipment and Liquid Concentrates*, as the basis for the investigation. Under UL 162, FFFs fall under the broad category of “synthetic (S)” foams and are defined as foams that have a chemical base other than a fluorinated surfactant or hydrolyzed protein. Because UL 162 was used as the basis of this assessment, the test parameters for synthetic foams were used.

The variables assessed during this program included the following:

- (1) Two discharge types: UL Type II with polar solvents and UL Type III with other fuels
- (2) Six foam types (all UL Listed): one alcohol-resistant C6 AFFF (AR-AFFF); three alcohol resistant FFFs (AR-FFF1, AR-FFF2, and AR-FFF3); and two hydrocarbon listed FFFs (H-FFF1 and H-FFF2)
- (3) Four fuel types: heptane, gasoline (MIL SPEC and E10), and isopropyl alcohol (IPA)
- (4) Fuel temperature: ambient temperature: 60°F (15°C); and high temperature: 85°F (30°C)
- (5) Discharge densities: up to three discharge densities
- (6) Two water types: freshwater and saltwater
- (7) Two foam qualities: lower aspiration (3 to 4 expansion) and higher aspiration (7 to 8 expansion)

The tests were conducted in two series. Series I focused on assessing the capabilities of these foams at a lower foam quality and aspiration, representative of a nonaspirating discharge device. Series II reassessed the foams at a higher foam quality and aspiration, representative of an aspirating discharge device.

The assessment was conducted on approval scale size fires. A 50 ft<sup>2</sup> (4.65 m<sup>2</sup>) square stainless-steel pan with sides 12 in. (30 cm) high was constructed. The pan was placed on concrete cinder blocks and skirted on three sides during each test. The pan was filled with the appropriate amount of fuel, typically 8 in. to 10 in. (20 cm to 25 cm) below the top of the pan.

During Type II tests, the nozzle was fixed, positioned, and aimed so that the spray impacted a backboard located on the opposite side of the pan. The nozzle remained fixed for the duration of the test. Most of the Type II tests were conducted using IPA as the test fuel with no water substrate.

During Type III tests, the foam nozzle was initially fixed and held still so that the spray impacted the fuel near the center of the fire pan until the intensity of the fire was reduced by approximately 90 percent (defined as control). Once the fire had been knocked down and controlled, the firefighter then manually directed the spray at the remaining fire in the pan while simultaneously cooling the sides. The firefighter was limited to two sides of the pan, and the nozzle was never allowed to extend over the edge of the pan as required by UL 162. The two types of tests are illustrated in Figure H.2.2(a).

During this assessment, 165 tests were conducted. To summarize the results, the baseline C6 AR-AFFF demonstrated consistent, superior firefighting capabilities through the entire test program under all test conditions. For the FFFs in general, the firefighting capabilities of the foams varied from manufacturer to manufacturer making it difficult to develop generic design requirements. This might also be the case with AFFFs, but only one was tested during this program, yielding no data to assess variability.

During the series II tests, all three AR-FFFs successfully extinguished the fires at rates 10 percent to 20 percent below the UL-listed parameters. The successful tests are summarized in Table H.2.2(a) and shown graphically in Figure H.2.2(b). All the Type II tests were conducted with the higher foam quality and aspiration rate.

The Type III tests were conducted with both higher and lower foam qualities and aspiration rates, using heptane, MILSPEC gasoline, and E10 gasoline.

Throughout this test program, heptane was shown to be the easiest of the test fuels to control and extinguish. The original five foams all met the UL 162 requirements at the design and recommended flow rates with the higher aspirated foam (higher foam quality) using heptane as the fuel. Gasoline was shown to be more difficult to control and extinguish than heptane, with some FFFs requiring as much as a 50 percent increase in flow rate to extinguish the fire. The E10 gasoline was even harder to extinguish than the MILSPEC gasoline. The three AR-FFFs required a 50 percent increase in flow and application rate to extinguish the E10 fires. The two H-FFFs required a 25 percent increase in flow and application rate to extinguish the E10 fires. Surprisingly, the H-FFFs were able to extinguish the E10 fires at a lower rate than the AR-FFFs. Independent of the flow and application rate, the FFFs typically

required about twice as much agent to extinguish the E10 fires as compared to the MILSPEC fires. In general terms and based on the extinguishment densities, it appears that MILSPEC gasoline is twice as hard to extinguish as heptane, and E10 gasoline is twice as hard as MILSPEC gasoline (four times as hard as heptane) for the FFFs. The results are summarized in Table H.2.2(b) and plotted in Figure H.2.2(c).

One of the major findings of the study was the effect that foam quality and aspiration had on the capabilities of the FFFs. In general, lower foam quality and aspiration rates caused a 20 percent to 50 percent increase in extinguishment densities as compared to higher foam quality and aspiration rates and had a greater impact on the alcohol-resistant foams than the FFFs approved only for hydrocarbon fuels. In some instances, the reduced aspiration and foam quality required higher application rates to extinguish the fires. These findings are summarized in Table H.2.2(c) and illustrated in Figure H.2.2(d). Figure H.2.2(d) only illustrates data for the tests conducted using freshwater for the foam solution.

During a study conducted for the FAA in the mid-90s, the firefighting capabilities (control and extinguishment times) of foam extinguishing agents were typically shown to follow an "L curve." An example L curve is shown in Figure H.2.2(e).

From a performance standpoint, this curve makes perfect sense. When the foam is applied at a high rate, the fire is quickly controlled and extinguished, as illustrated by the right side of the plot where the performance levels off even though the foam is being applied at higher rates. As the application rate is reduced, the times tend to increase as the rate approaches a critical value. Specifically, the times asymptotically approach the rate where the foam is being consumed by the fire as fast as it is being applied. In Figure H.2.2(e), this asymptotic value is just below 0.03 gpm/ft<sup>2</sup> (1.2 L/min/m<sup>2</sup>). These tendencies are used to describe the capabilities of the FFFs in the following paragraphs. The L curves for the foams included in this assessment — AR-AFFF, AR-FFFs, and H-FFFs — are shown in Figure H.2.2(f) for the hydrocarbon-based fuels — heptane, E10 gasoline, and MILSPEC gasoline.

When comparing the capabilities of the FFFs to the baseline AFFF at the same foam quality and aspiration, the FFFs typically required between 1.5 to 3 times the application rates to produce comparable performance for the fuels included in this assessment [heptane, gasoline (E10 and MILSPEC), and IPA]. When comparing the capabilities of the AR-FFFs to the H-FFFs, the H-FFFs were similar to the AR-FFFs at a 40-percent reduced flow rate for the lower expanded foam and a 30-percent reduced rate for the higher expanded foam. Consequently, the use of higher aspirated foam reduced the differences in capabilities between the two FFF types (i.e., alcohol-resistant and hydrocarbon FFFs). These capabilities are plotted in Figure H.2.2(f) as a function of foam type.

With respect to elevated fuel temperatures, the results were consistent over the range in ambient and fuel temperatures included in this assessment. With that said, it is understood that fires involving boiling flammable liquids are much harder to extinguish than fires that are combatted prior to the transition into boiling. The type of water (i.e., freshwater versus saltwater) was also shown to have a minimal effect on the firefighting capabilities of the FFFs and varied between foams.

Table H.2.2(a) Successful Type II Test Results (IPA)

Foam	Type of Discharge	Fuel Type	Water Type	Flow Rate	Exp. Ratio	Cont. sec	Cont. gal/ft <sup>2</sup>	Ext. sec	Ext. gal/ft <sup>2</sup>
AR-AFFF	Type II	IPA	Fresh	2.25 gpm	7-8	160	0.12	270	0.203
AR-AFFF	Type II	IPA	Salt	2.25 gpm	7-8	140	0.105	270	0.203
AR-FFF1	Type II	IPA	Fresh	8.0 gpm	7-8	135	0.36	275	0.733
AR-FFF1	Type II	IPA	Salt	8.0 gpm	7-8	96	0.256	215	0.573
AR-FFF2	Type II	IPA	Fresh	8.0 gpm	7-8	120	0.32	295	0.787
AR-FFF2	Type II	IPA	Salt	8.0 gpm	7-8	115	0.307	255	0.68
AR-FFF3	Type II	IPA	Fresh	5.0 gpm	7-8	100	0.167	270	0.45

For SI units, 1 gpm = 3.8 L/min; 1 gal/ft<sup>2</sup> = 40 L/m<sup>2</sup>.

Table H.2.2(b) Summary of Findings: Fuel Type and Agent Comparison — Higher Aspirated Foam with Freshwater

Foam	Type of Discharge	Water Type	Exp. Ratio	Heptane		MILSPEC		E(10)	
				Flow Rate	Ext. gal/ft <sup>2</sup>	Flow Rate	Ext. gal/ft <sup>2</sup>	Flow Rate	Ext. gal/ft <sup>2</sup>
AR-AFFF	Type III	Fresh	7-8	3.0 gpm	0.051	3.0 gpm	0.065	3.0 gpm	0.06
AR-FFF1	Type III	Fresh	7-8	3.0 gpm	0.105	3.0 gpm	0.22	4.5 gpm	0.413
AR-FFF2	Type III	Fresh	7-8	3.0 gpm	0.107	3.0 gpm	0.21	4.5 gpm	0.383
AR-FFF3	Type III	Fresh	7-8	3.0 gpm		3.0 gpm	0.23	4.5 gpm	0.353
FFF1	Type III	Fresh	7-8	3.0 gpm	0.092	3.0 gpm	0.185	3.75 gpm	0.356
FFF2	Type III	Fresh	7-8	3.0 gpm	0.055	3.0 gpm	0.17	3.75 gpm	0.363

Table H.2.2(c) Foam Quality and Aspiration Comparison (MILSPEC Gasoline — Densities)

Foam	Type of Discharge	Fuel Type	Water Type	3 to 4 Expansion Ratio		7 to 8 Expansion Ratio	
				Flow Rate	Ext gal/ft <sup>2</sup>	Flow Rate	Ext gal/ft <sup>2</sup>
AR-FFF1	Type III	MILSPEC	Fresh	4.5 gpm	0.45	3.0 gpm	0.25
AR-FFF1	Type III	MILSPEC	Salt	4.5 gpm	0.375	3.0 gpm	0.26
AR-FFF2	Type III	MILSPEC	Fresh	4.5 gpm	0.39	3.0 gpm	0.255
AR-FFF2	Type III	MILSPEC	Salt	4.5 gpm	0.375	3.0 gpm	0.27
FFF1	Type III	MILSPEC	Fresh	3.0 gpm	0.165	3.0 gpm	0.15
FFF1	Type III	MILSPEC	Salt	3.0 gpm	0.29	3.0 gpm	0.21
FFF2	Type III	MILSPEC	Fresh	3.0 gpm	0.187	3.0 gpm	0.16



Type II Configuration

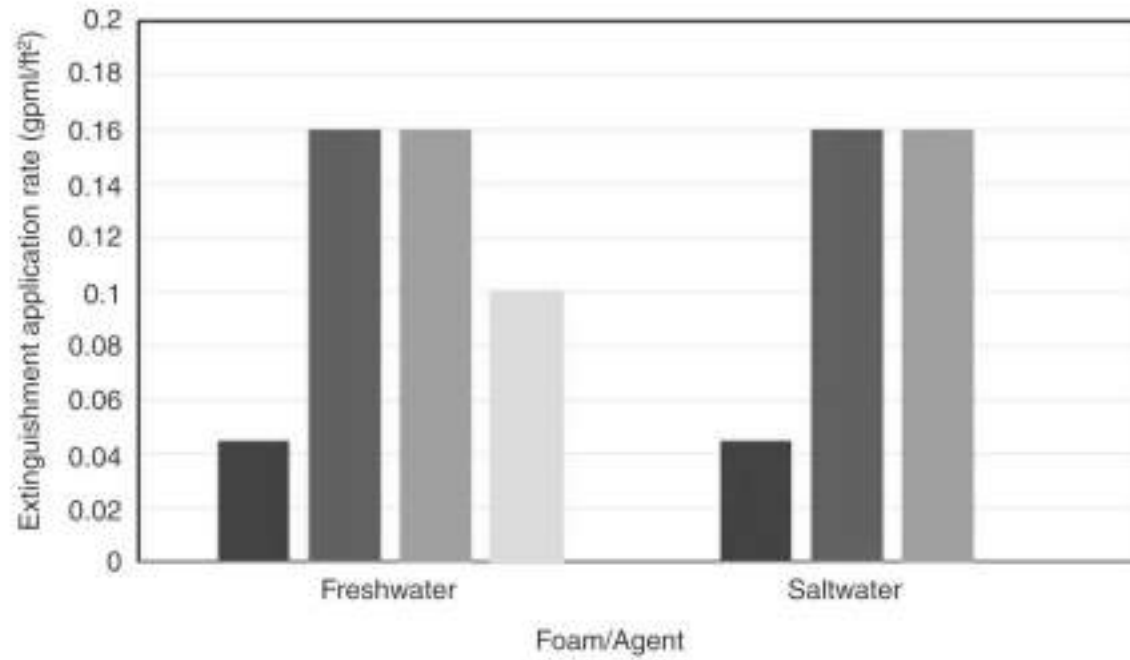


Type III Configuration

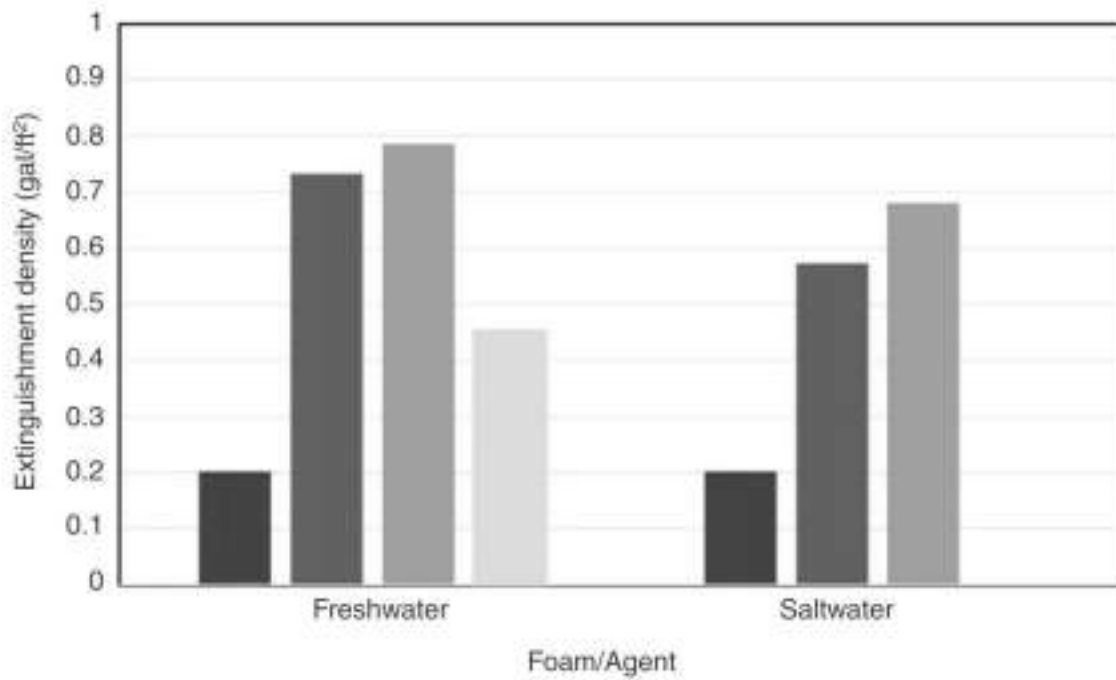
FIGURE H.2.2(a) Test Configurations.



## Application Rate



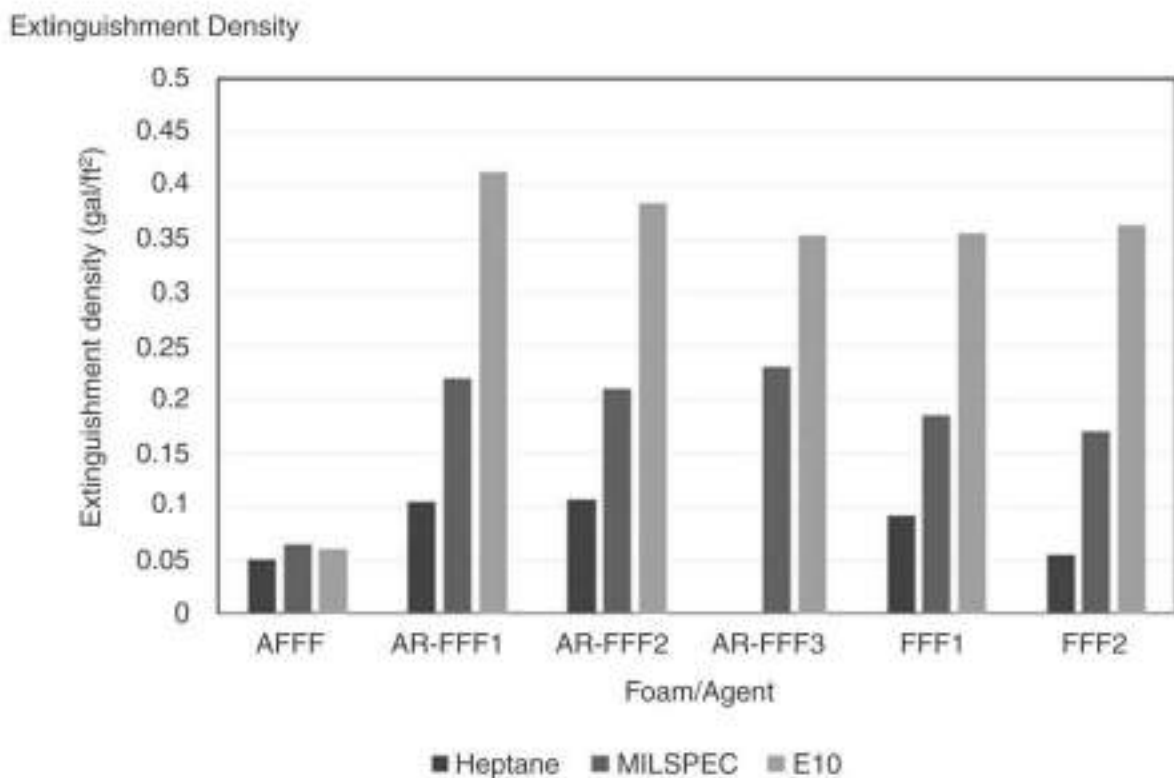
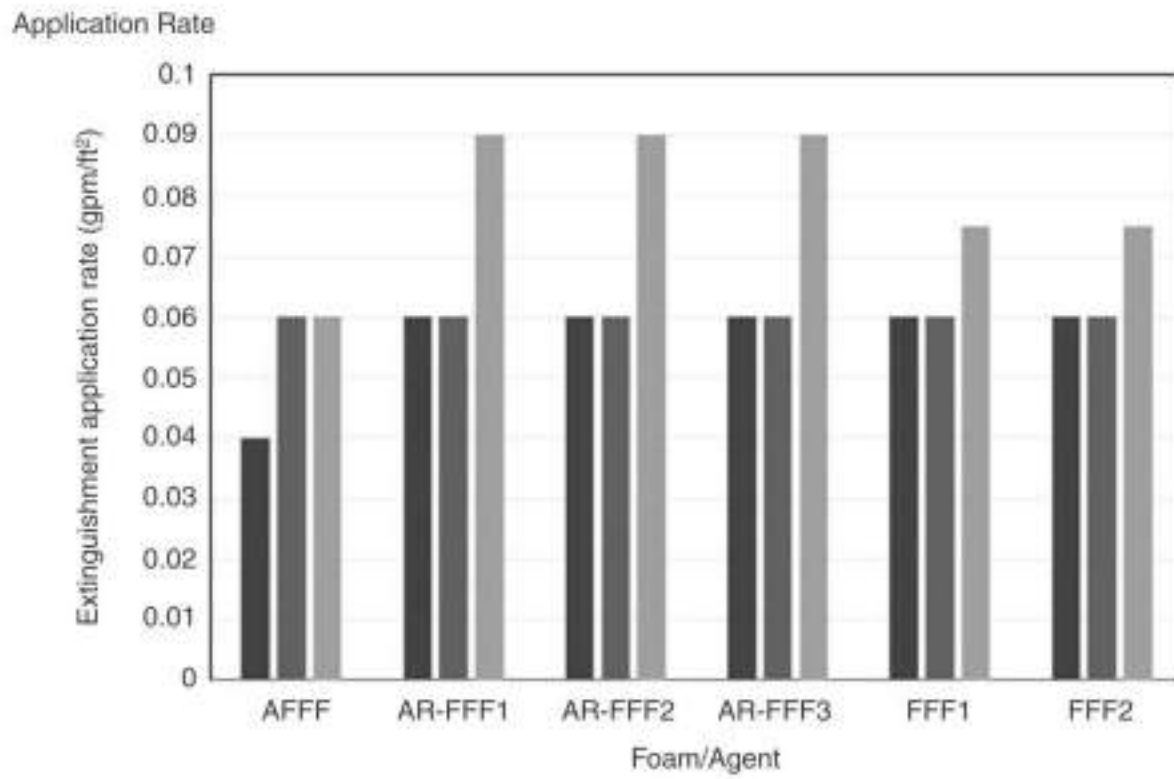
## Extinguishment Density



■ AFFF ■ AR-FFF1 ■ AR-FFF2 ■ AR-FFF3

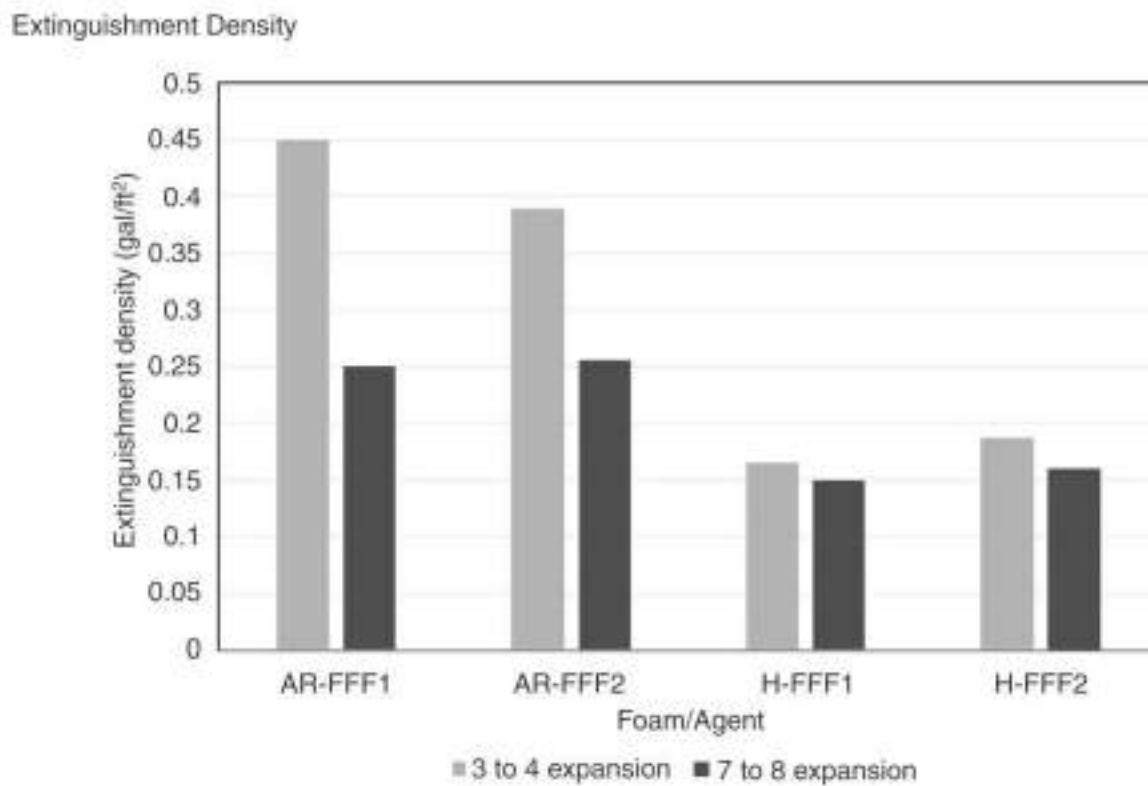
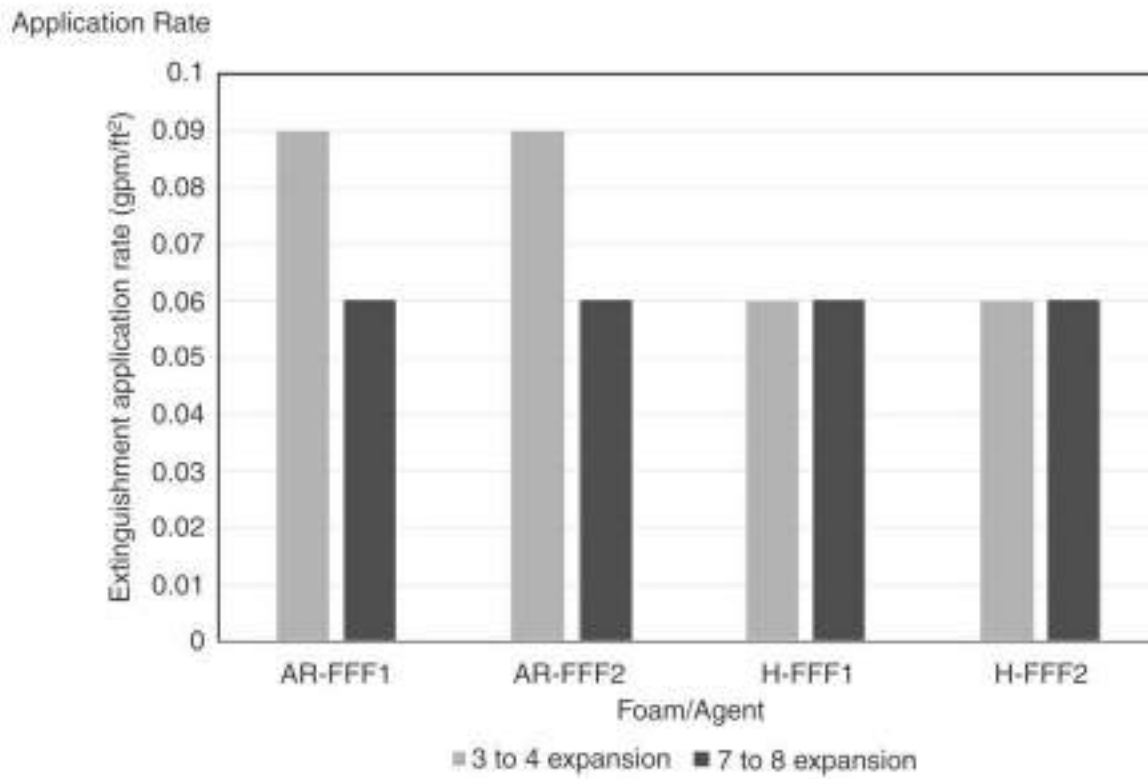
For SI conversions: 1 gpm = 3.8 L/min; 1 gal/ft<sup>2</sup> = 40 L/min/m<sup>2</sup>.

**FIGURE H.2.2(b) Type II IPA Foam Comparison.**



For SI conversions: 1 gpm = 3.8 L/min; 1 gal/ft<sup>2</sup> = 40 L/min/m<sup>2</sup>.

**FIGURE H.2.2(c) Fuel Type and Agent Comparison — Higher Aspirated Foam with Freshwater.**



For SI conversions: 1 gpm = 3.8 L/min; 1 gpm/ft<sup>2</sup> = 40 L/min/m<sup>2</sup>.

**FIGURE H.2.2(d) Foam Quality and Aspiration Comparison — MILSPEC Gasoline and Freshwater.**

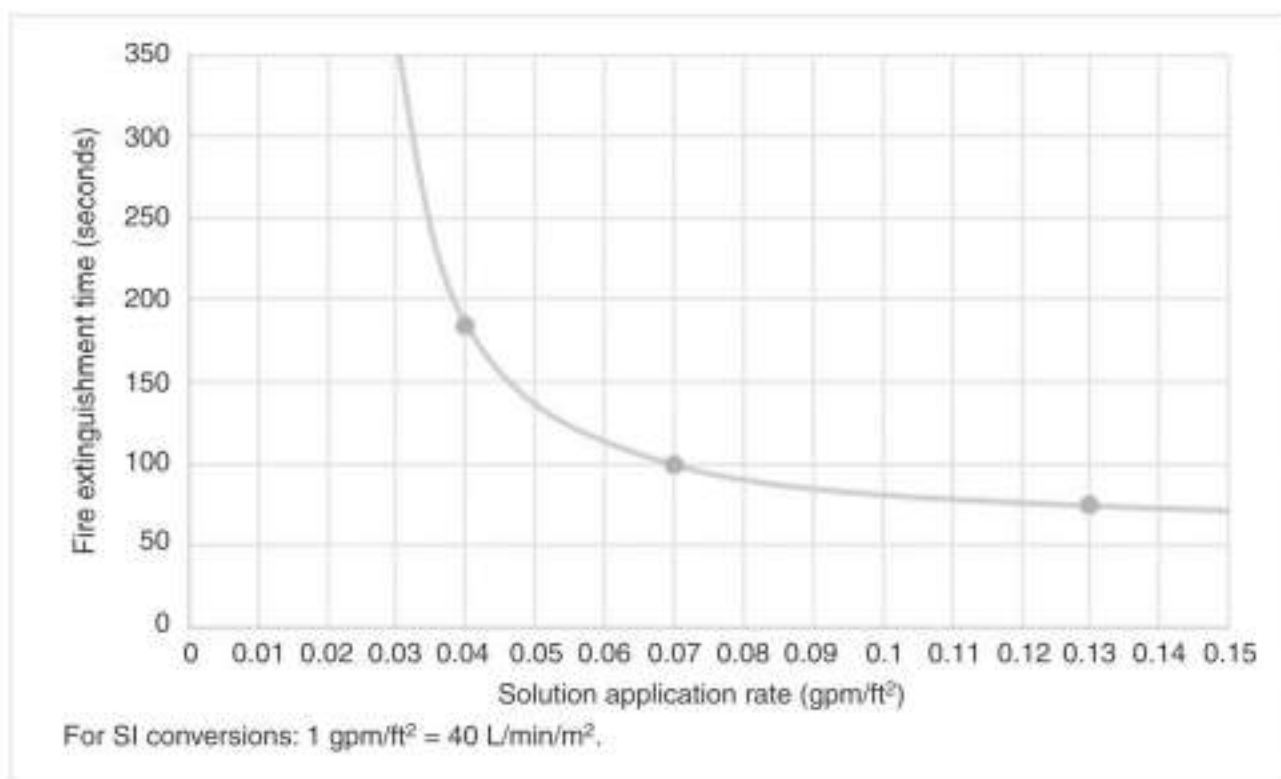


FIGURE H.2.2(e) Firefighting Control and Extinguishment Times — L Curve.

**H.2.3 Key Points and Conclusions.** In summary, the results demonstrated that, while FFFs have come a long way, there is more to learn about their capabilities and limitations. As of today, FFFs are not a drop-in replacement for AFFF. However, some can be made to perform effectively as an AFFF alternative with proper testing and design (i.e., with higher application rates and densities).

The baseline C6 AR-AFFF performed well against all test fuels included in this assessment — IPA, heptane, and gasoline (MILSPEC and E10). The FFFs did well against heptane but struggled against some of the scenarios conducted with IPA and gasoline (both MILSPEC and E10), especially when the foam was discharged with a lower foam quality and aspiration. The FFFs typically required between 1.5 to 3 times the application rates to produce comparable performance as the baseline AR-AFFF for the range of parameters included in this assessment. The extinguishment densities for the FFFs were typically 2 to 4 times greater than the baseline AR-AFFF for the IPA fires conducted with the Type II test configuration, 3 to 4 times greater than the baseline AR-AFFF for the tests conducted with MILSPEC gasoline, and between 6 to 7 times greater than the baseline AR-AFFF for the tests conducted with E10 gasoline.

With respect to the types of FFFs (i.e., alcohol-resistant versus hydrocarbon), the H-FFFs typically demonstrated better capabilities than the AR-FFFs. In general, for the tests conducted with the lower aspiration, the extinguishment densities for the AR-FFFs were about twice that of the H-FFFs. This difference was reduced with the use of the higher aspirated foams. For the tests conducted with the higher aspirated foams, the extinguishment densities for the AR-FFFs were, on average, about 1.5 times that of the H-FFFs. However, the AR-FFFs

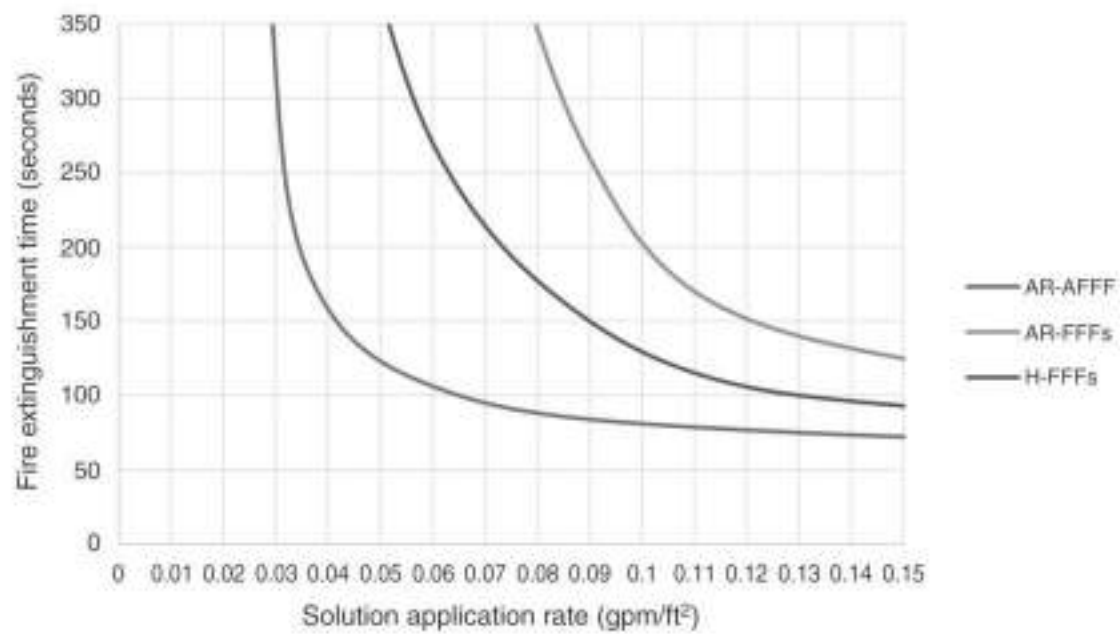
required a higher flow and application rate of 1.5 times that of the H-FFFs against the E10 fires to achieve those results.

The results also showed that the legacy fuel — heptane — used to list and approve foams might not be a good surrogate for all hydrocarbon-based fuels. Some foams struggled against other fuels, like gasoline, compared to heptane. Going forward, it was recommended that FFFs be tested and listed for a variety of hydrocarbon fuels, the approach currently used for polar solvent listings and approvals.

Due to its oleophobic properties, AFFF has two separate mechanisms that combine to aid in the extinguishment of a flammable liquid fire: a water and surfactant film that forms on the fuel surface and a foam blanket of bubbles, both of which serve to seal in the flammable vapors resulting in extinguishment (i.e., shutting off the fuel vapors that are burning above the fuel surface). FFFs have only the foam blanket to seal in the vapors. As a result, the capabilities of FFFs will be highly dependent on the characteristics of the foam blanket, which depend on the associated discharge devices as well as the foam type itself. The film produced by AFFF has provided an additional level of protection for systems and discharge devices that do not produce aspirated foam. Additional attention will need to be given to the discharge devices identified as part of the UL listing when using these foams.

Ultimately, end users will need to design and install within the listed parameters to ensure a high probability of success during an actual event. This applies not only to the discharge devices but also to the proportioning systems, due to the highly viscous nature of some of the FFF concentrates.

(3 to 4 expansion)



(7 to 8 expansion)

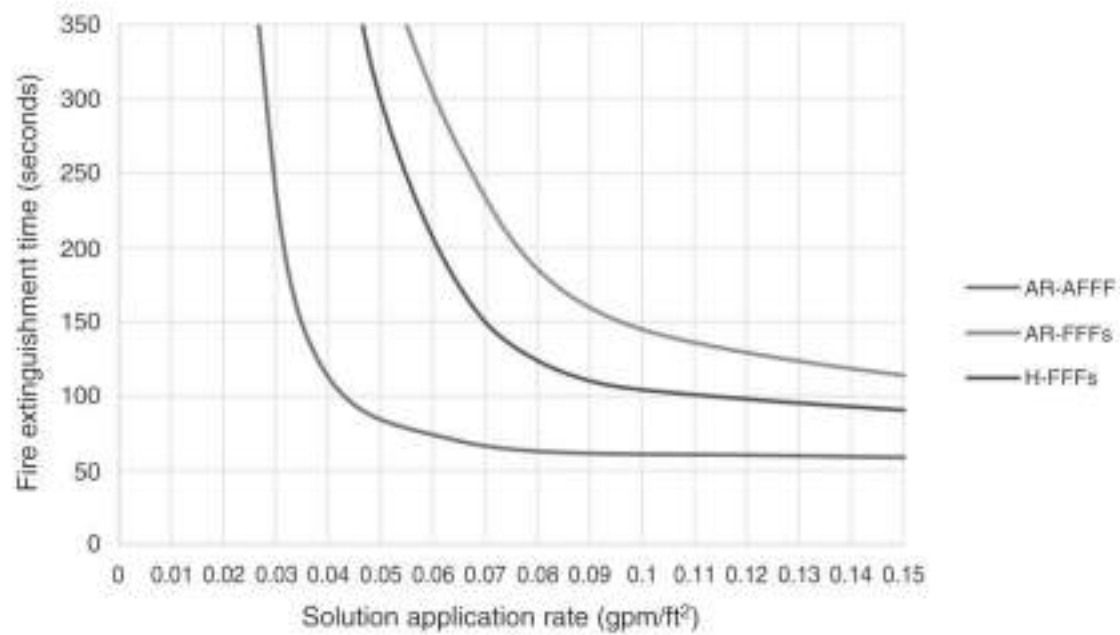
For SI conversions: 1 gpm/ft<sup>2</sup> = 40 L/min/m<sup>2</sup>.

FIGURE H.2.2(f) L Curves Illustrating Extinguishment Capabilities (Agent-Type Comparison).

### H.3 Testing Conducted by LASTFIRE.

**H.3.1 General.** Increasing environmental concerns related to fluorosurfactant-containing foams (PFAs) and the potential for regulatory controls have prompted a number of organizations to carry out extensive testing of new generation fluorine-free foams. In particular, the FPRF and LASTFIRE (the international Joint Industry Project developing best practice guidance for storage tank fire hazard management) conducted extensive complementary, independently managed testing. Key conclusions from LASTFIRE are summarized in this section but full reports are available from the respective organizations.

Because there are ongoing developments in this field, it is worthwhile to check for any updates in knowledge that might be relevant and assist in optimizing effectiveness prior to finalizing any foam application system design.

It should be noted that, while emphasis was placed on fluorine-free foams, testing was also carried out on new generation post-EPA stewardship program C6-based fluorosurfactant-containing foams. Such foams were developed to reduce the use of C8-based materials and minimize contamination levels of C8 fluorosurfactants in C6-based formulations. While such foams are film forming and generally work on the same principles as older formulations, they have not been subjected to the same levels of large-scale testing or actual incident application.

**H.3.2 Report Summary.** LASTFIRE carried out a range of testing, normally totally funded by the organization, but also as independent witnesses of work carried out by others, including foam and equipment suppliers. The objective was to provide a firm basis for future cost-effective, long-term, sustainable policies regarding the selection and use of firefighting foam based on rational, relevant, and independent end-user-driven test programs.

Following are the series of tests conducted, including logical progression from small-scale in accordance with recognized test standards through to large-scale, real-life scenarios using this standard's design guidelines for test protocol development. Full reports for most of the tests are available from LASTFIRE.

- (1) A series of small-scale tests of five different FFFs and both C6 and C8 (as a proven reference) fluorosurfactant-containing foams. This included testing to EN1568 (European norm) and LASTFIRE (a specific protocol designed by LASTFIRE to simulate storage tank fires) test protocols. Such tests were carried out at approximately 50 percent of the application rate used in practice based on recognized standards such as this standard.
- (2) Small-scale [50 ft<sup>2</sup> (5 m<sup>2</sup>) and 200 ft<sup>2</sup> (20 m<sup>2</sup>)] spill fires using the same foam concentrates with a number of application techniques, including plunging (Type 3) semi-aspirating "monitor," aspirating "monitor," medium expansion and compressed air foam nozzles, and system pourer nozzles (Type 2). These tests included obstructions in the pan to simulate pipework, and so forth, that might disrupt foam movement and cause additional hot surfaces to seal against.
- (3) Proportioning tests for the same foam concentrates using both venturi-based standard in-line proportioners and positive displacement pumped proportioning systems.
- (4) Large-scale tank [1080 ft<sup>2</sup> (100 m<sup>2</sup>) surface area, 36 ft (11 m) diameter, 30 ft (9m) high] application using the same foams but at this standard's system design rates using aspirating monitors, nonaspirating monitors, system pourer, and CAF monitor application. Note: The CAF application rate was approximately 75 percent of the conventional foam application rate. These tests were intended to validate the smaller scale testing and demonstrate the effectiveness of new generation foams when used at typical application rates using proprietary equipment. FFFs successfully extinguished fires in these tests. [See Figure H.3.2(a).]
- (5) Long-flow [100 ft (30 m) and 130 ft (40 m)] application on Jet A fuel using conventional pourer and CAF pourer applications at typical design application rates. Only one FFF was taken through to this test. The application rate for CAF pourer was 0.7 gpm/ft<sup>2</sup> (2 L/min/m<sup>2</sup>), for conventional pourer 1.4 gpm/ft<sup>2</sup> (4 L/min/m<sup>2</sup>). These tests successfully extinguished fires. [See Figure H.3.2(b).] Some of the results are as follows:
  - (a) Conventional foam pourer application at 1.4 gpm/ft<sup>2</sup> (4 L/min/m<sup>2</sup>), extinguishment at 100 ft (30 m) flow – 2'32"
  - (b) CAF based foam pourer application at 0.7 gpm/ft<sup>2</sup> (2 L/min/m<sup>2</sup>), extinguishment at 100 ft (30 m) flow – 2'23"
- (6) Subsurface application of one FFF on Jet A fuel using a test procedure based on UL 162. Successful extinguishment was accomplished with both conventional and CAF-based applications. [See Figure H.3.2(c).]
- (7) Vapor suppression tests with both FFF and C6 fluorosurfactant-containing foams in fire and nonfire situations, using an array of vapor detectors over the LASTFIRE test.
- (8) Hybrid monitor application using low expansion FFF to carry medium expansion foam further (claiming to lead to less forceful plunging into the fuel) than one FFF on 5650 ft<sup>2</sup> (525 m<sup>2</sup>) diesel fire at typical application rates used in practice.
- (9) Bund length 65 ft (20 m) flow testing of one FFF in system pourer application using approximately 75 percent of typical application rates — with extensive obstructions in the path of foam. Fire was successfully extinguished.
- (10) Testing of one additional FFF in a 36 ft diameter (11 m diameter), 6.6 ft (2 m) high tank at approximately 75 percent of normal design application rates. Fire was successfully extinguished.
- (11) Small-scale testing of a self-expanding foam (SEF) application system using FFF and the LASTFIRE test protocol adapted for SEF application. (SEF uses a premix foam solution held under CO<sub>2</sub> pressure. On actuation, the CO<sub>2</sub> comes out of solution and forms foam bubbles.)

Throughout the tests a variety of fuels were used, including heptane, gasoline, diesel, crude, Jet A-1, and ethanol. In addition, some tests included both saltwater and freshwater applications. At times compatibility with dry chemical was also assessed.



FIGURE H.3.2(a) From LASTFIRE: FFF — 36 ft (11 m) Tank Fire Testing.



FIGURE H.3.2(b) A 98 ft (30 m) Flow Test Approaching Full Extinguishment.



FIGURE H.3.2(c) Extinguishing Sequence, FFF, Subsurface Injection.

**H.3.3 Key Points and Conclusions.** LASTFIRE concluded that some FFFs are suitable for some applications, including hydrocarbon spill fires and smaller storage tanks subject to validated testing of the specific foam and application device. The LASTFIRE Group is confident that other applications can be proven with additional test work.

Further phases of testing are planned, including small-scale testing to optimize foam properties through equipment design, thereby maximizing extinguishing performance. In addition, further large-scale testing [165 ft (50 m) flow length] trials are to be carried out with a range of FFFs using both monitor and pourer applications.

These extensive testing programs have resulted in the following critical findings relevant to application of new generation foams. Although the focus is on FFFs, some apply to both "post-EPA stewardship" C6-based formulations.

- (1) With the current stage of development of FFFs and the wide range of products being developed, it is not possible to be generic in terms of the performance of this type of foam concentrate on any specific fuel. Thus, it is important to base any system design on recognized and scenario-relevant approval tests, including the appropriate fuel, ideally also validated by larger scale testing.
- (2) Foam performance is dependent on application equipment as well as foam concentrate and application rate. This is true with all foam types but appears to be particularly the case with FFF types. Undoubtedly, they all work more effectively with aspirating equipment, although LASTFIRE testing showed that some can work also with typical nonaspirating equipment.
- (3) Physical properties as well as firefighting performance are critical to ensuring appropriate performance. Some FFFs, particularly those having high viscosity, might require modifications to the proportioning system to ensure a pick-up rate within acceptable tolerances. No foam of any type should be regarded as a drop-in replacement without fully evaluating extinguishing performance and system and equipment suitability and compatibility.
- (4) Compressed air foam can provide effective extinguishing performance with FFF at lower application rates than conventionally generated foam — again, subject to validation through testing for a specific set of circumstances.
- (5) It is recognized that further work should be carried out on other fuel types, especially water soluble polar solvent fuels, including alcohols such as IPA. Note: The ETANK-FIRE Project of the SP Technical Research Institute of Sweden carried out some small-scale testing of FFFs on ethanol, but larger scale work is required to develop and validate application design rules.
- (6) It is important that a validated test method specifically relevant to the application is used to determine system design characteristics wherever possible. Ideally a performance-based method should be used so that the end user can adjust parameters such as application rate, run time, or proportioning rate to suit the performance of the foam if necessary.
- (7) It is recognized that a major gap in knowledge still exists in the application of any new generation foam, but particularly FFF types to large diameter tank fires using large throughput monitors, especially nonaspirating types. While the comparative tests on smaller tank fires [36 ft (11 m) diameter] have shown effective performance can

be achieved with some foam and equipment combinations, this has not been validated in larger scale testing.

### Annex I Rim Seal Fire Test Protocol

*This annex is not a part of the requirements of this NFPA document but is included for informational purposes only. Information in this annex is intended to be adopted by the jurisdiction at the discretion of the adopting jurisdiction. Additionally, information in this annex is intended to be incorporated on a voluntary basis by building owners and developers who might have a desire to include supplemental evacuation equipment in their projects.*

*Although this annex is written in mandatory language, it is not intended to be enforced or applied unless specifically adopted by the jurisdiction or, if it is being applied on a voluntary basis, by the building owner or developer.*

*The following protocol was developed as a methodology to demonstrate that a nonmetallic floating roof structure has sufficient fire resistance to withstand the effects of a foreseeable rim seal and/or spill on roof fire to such an extent to maintain its integrity for sufficient time to allow extinguishment of a rim seal fire. It was developed by an industry group developing best practice guidance for storage tank fire hazard management.*

*The test protocols in this annex were developed using SI units. Inch-pound conversion units provided were not part of the original testing protocols.*

#### I.1 Test Rigs.

**I.1.1** The following two tests shall be carried out:

- (1) Roof test
- (2) Roof, seal assembly, and foam dam test

#### I.1.2 Roof Test.

**I.1.2.1** The roof test shall be conducted in accordance with I.1.2.1.1 through I.1.2.1.4.

**I.1.2.1.1** The roof test shall be carried out in an 8 ft (2.44 m) diameter test pan, as illustrated in Figure I.1.2.1.1.

**I.1.2.1.2** The roof in this test shall be subjected to a spill on roof fire, covering the full surface but limited in duration by the fuel burn and regression rate, followed by a fire in the center of the roof within a hole 600 mm (24 in.) in diameter.

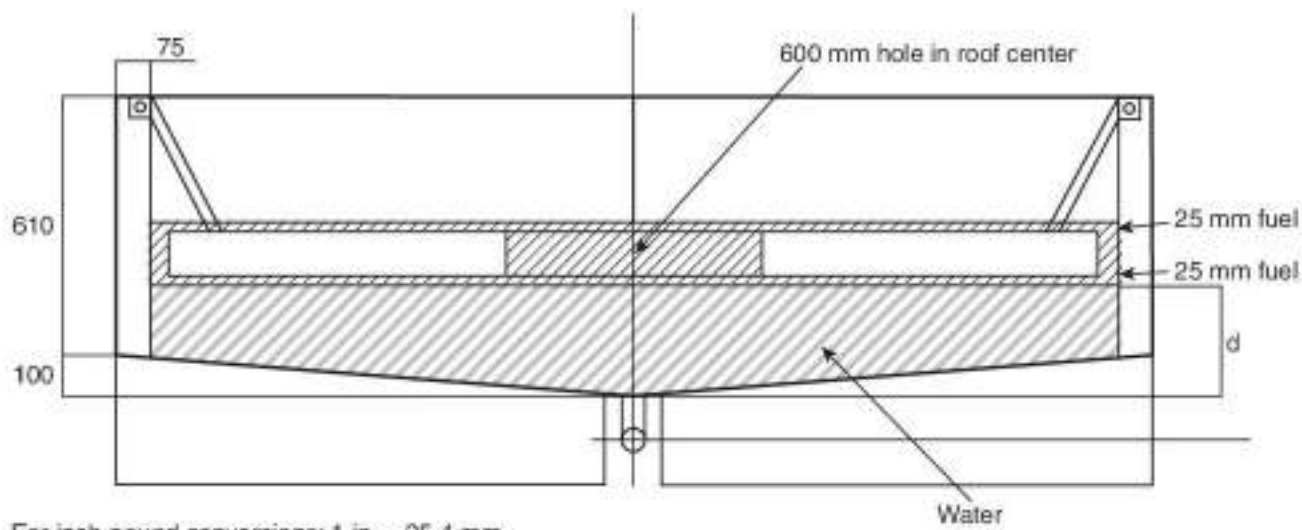
**I.1.2.1.3** The rim area around the roof shall also be subject to burning.

**I.1.2.1.4** The general arrangement shall be as shown in Figure I.1.2.1.1 and the construction drawing in Figure I.1.2.1.4.

**I.1.2.2** The roof sample shall be provided with an edge rim 150 mm (5.9 in.) in height if a rim is provided in actual installations.

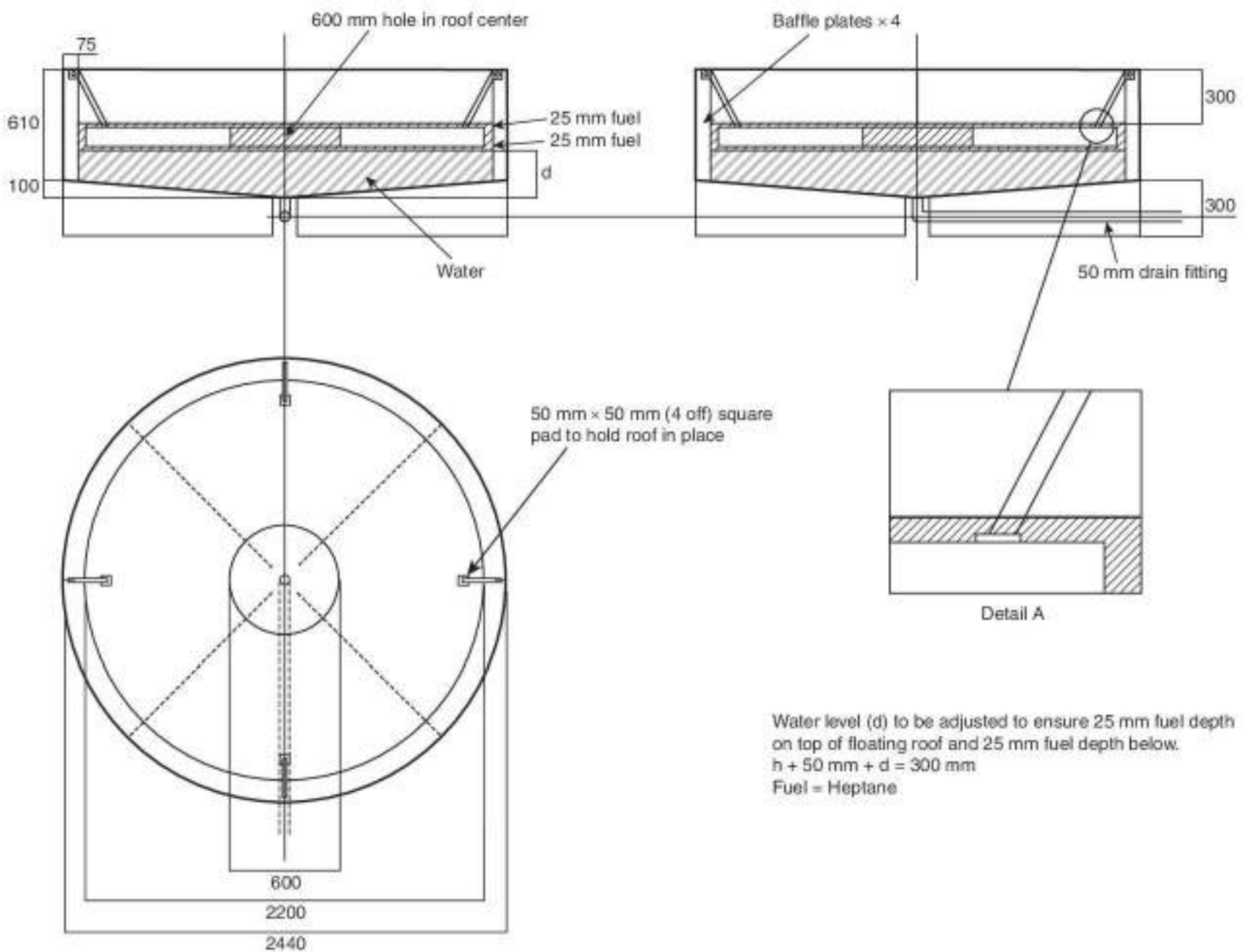
**I.1.2.3** Roof-holding struts shall be provided to stabilize the glass reinforced epoxy (GRE) roof (which has inherent buoyancy) and maintain a 25 mm (1 in.) fuel layer on top of the roof, as illustrated in Figure I.1.2.3.





For inch-pound conversions: 1 in. = 25.4 mm.

FIGURE I.1.2.1.1 General Layout of Roof Test.



For inch-pound conversions: 1 in. = 25.4 mm.

FIGURE I.1.2.1.4 Roof Test General Arrangement and Pan/Construction Drawing.

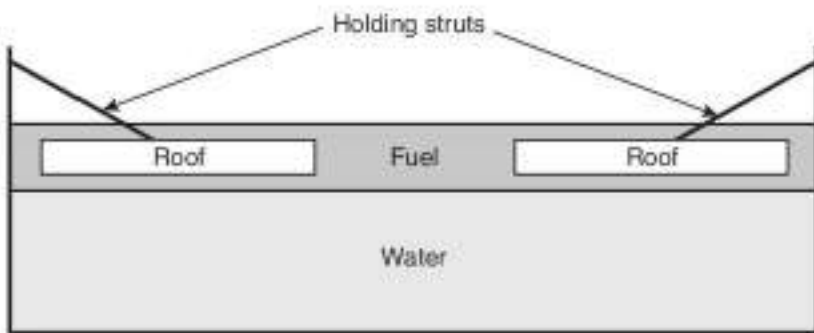


FIGURE I.1.2.3 Roof-Holding Struts for Stability.

I.1.2.4 Exposed fuel areas, and therefore, areas subject to burning (see Figure I.1.2.4), shall be as follows:

- (1) Over the entire roof for the duration of the full-surface burn, simulating a spill on roof and relatively short-lived fire
- (2) In the center of the roof in the area bounded by the 600 mm (24 in.) diameter hole cut through the roof sample from the top deck to the underside
- (3) Around the full circumference of the roof

### I.1.3 Roof, Seal, and Foam Dam Assembly Test (Rim Seal Fire Test).

I.1.3.1 The roof, seal, and foam dam assembly test shall be conducted in accordance with I.1.3.1.1 through I.1.3.1.4.

I.1.3.1.1 The test shall be carried out on a rig with the general arrangement depicted in Figure I.1.3.1.1.

I.1.3.1.2 The rig shall be designed to accommodate a rectangular roof slab, with corresponding rim seal and foam dam.

I.1.3.1.3 Fixing points shall be provided on the rig for the rim seal and the dam.

I.1.3.1.4 The roof, seal, and foam dam shall be exposed to a rim seal fire occurring in the rim gap between the rear of the rig (tank wall) and the roof.

### I.1.3.2 The Rig.

I.1.3.2.1 The rig shall be designed to accommodate a roof slab with a nominal length of 3 m (9.8 ft), width of 400 mm (15.75 in.), and thickness of 68 mm (2.68 in.).

I.1.3.2.2 The roof slab, rim seal, and foam dam together shall be termed the *roof assembly* [see Figure I.1.3.2.2(a) through Figure I.1.3.2.2(h)].

I.1.3.3 **Foam Dam.** The foam dam shall be a height of 600 mm (23.6 in., approx. 2 ft) assembled to the roof slab at a distance of 100 mm (approx. 3.94 in.) from the leading edge of the roof, that is, the part of the roof that would normally be furthest from the tank shell.

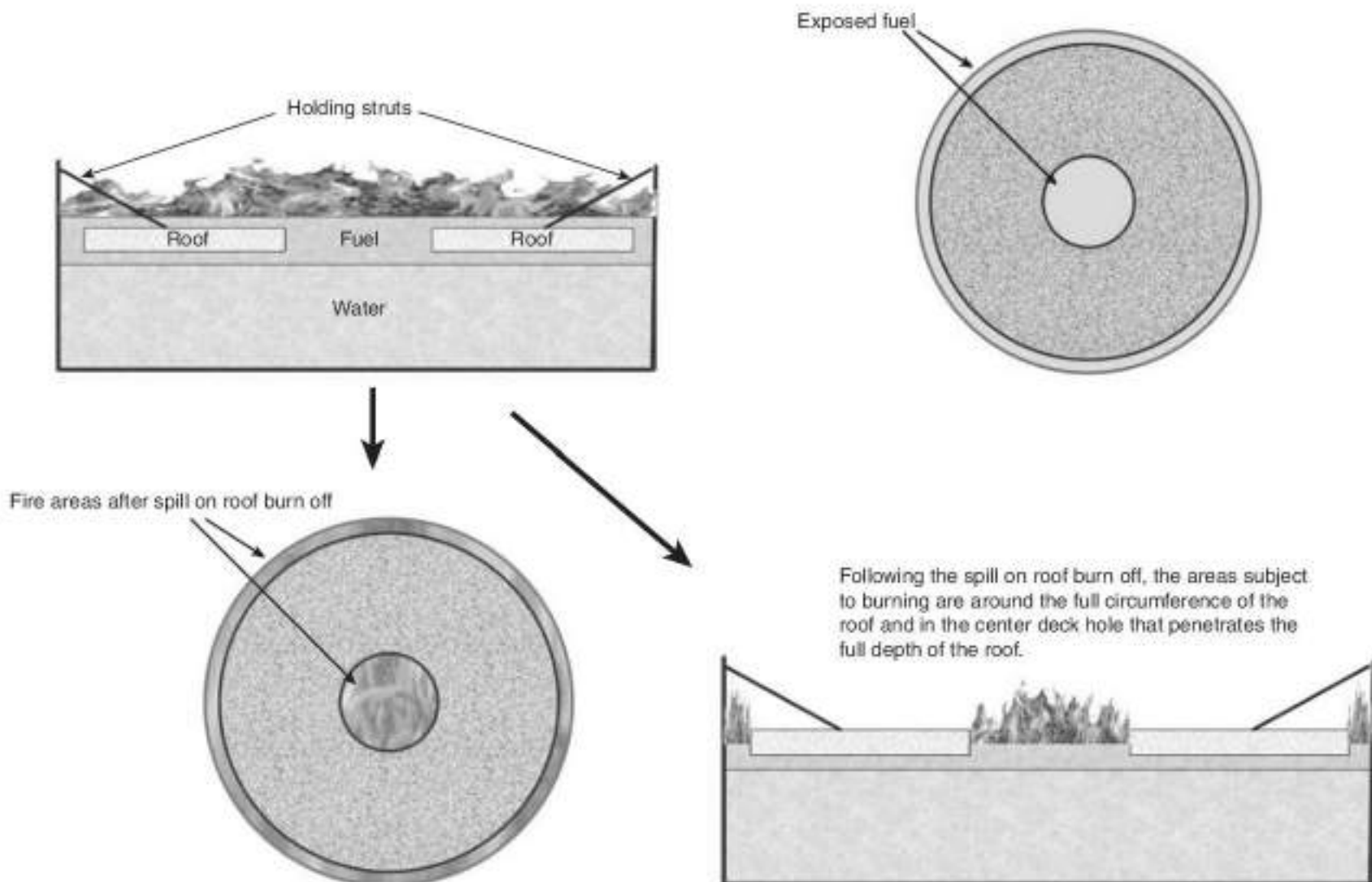


FIGURE I.1.2.4 Fire Areas During Roof Test.

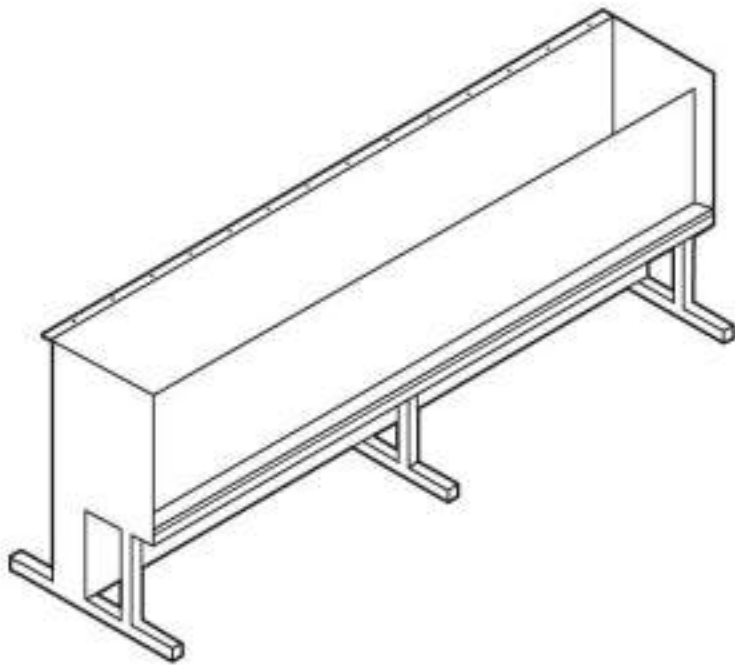
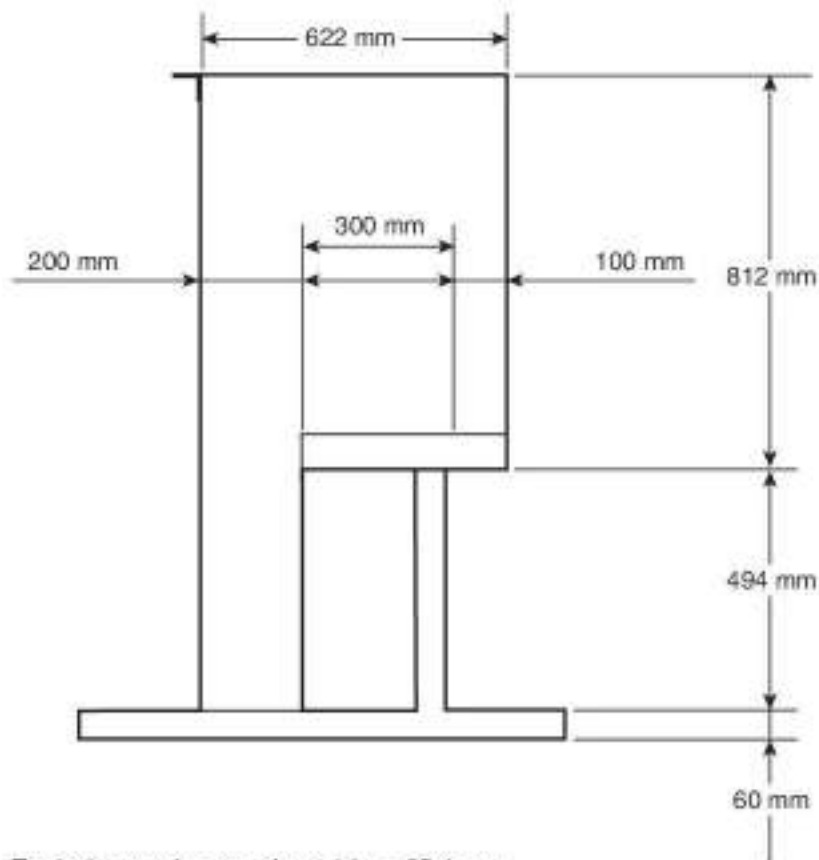


FIGURE I.1.3.1.1 General Arrangement of Test Rig for Roof Assembly — a Typical Sample.

#### I.1.3.4 Rim Seal.

I.1.3.4.1 The rim seal assembly, either as a primary seal or a secondary seal, shall be as provided by the manufacturer or supplier.

I.1.3.4.1.1 It shall be assembled to the roof slab sample and test rig such that the seal covers the rim gap fully without distortion and with uniform pressure as far as is practicable.



For inch-pound conversions: 1 in. = 25.4 mm.

FIGURE I.1.3.2.2(a) Rim Seal Test Rig Construction Drawing (1).

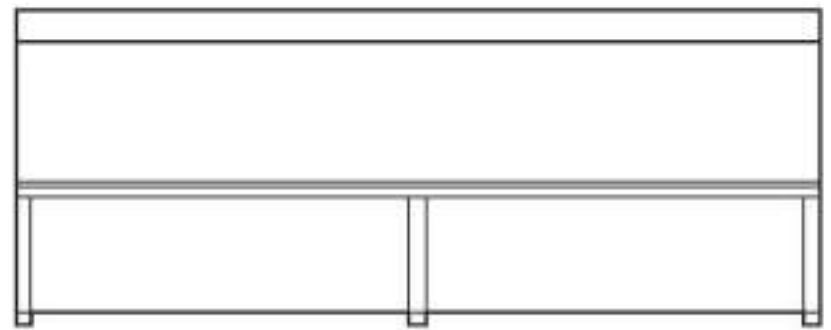


FIGURE I.1.3.2.2(b) Rim Seal Test Rig Construction Drawing (2).

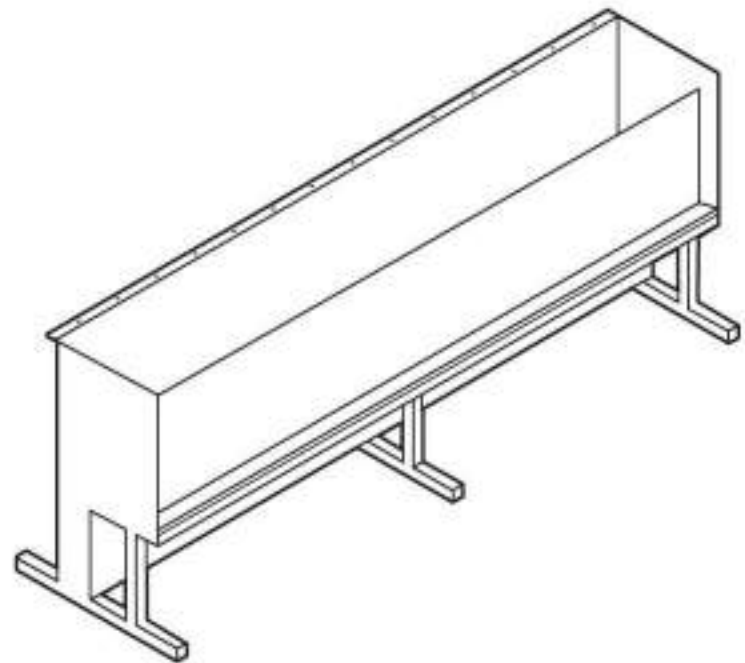


FIGURE I.1.3.2.2(c) Rim Seal Test Rig Construction Drawing (3).

I.1.3.4.1.2 The test rig rim gap shall be, ideally, 200 mm (approx. 7.9 in.), but no less than 150 mm (5.9 in.).

I.1.3.4.2 The rig shall have suitable fixing points for a range of seal types.

I.1.3.4.3 Nominally, there shall be fixing points every 260 mm (approx. 10 in.), as indicated in Figure I.1.3.2.2(d).

I.1.3.4.4 Seals shall be supplied with or without wax scrapers and other appurtenances according to the design.

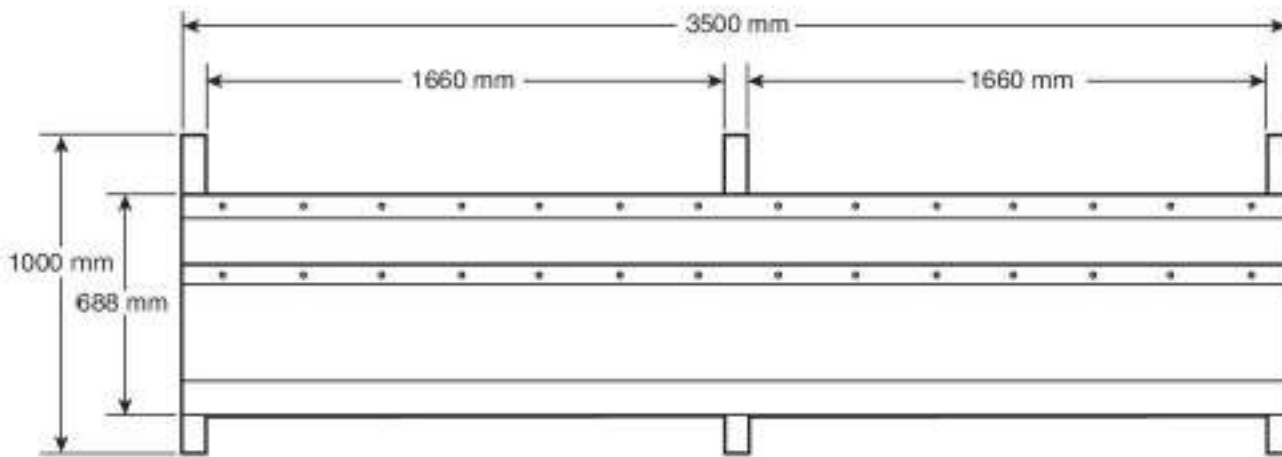
## I.2 Test Procedures.

### I.2.1 Roof Test.

I.2.1.1 The roof shall be subjected to a limited duration spill on roof fire, covering the full surface.

I.2.1.2 Once this fire has diminished, the roof shall be subjected to a fire in the center deck 600 mm (24 in.) diameter hole and a rim seal fire.

I.2.1.3 The test sequence shall be as outlined in Table I.2.1.3.



For inch-pound conversions: 1 in. = 25.4 mm.

FIGURE I.1.3.2.2(d) Rim Seal Test Rig Construction Drawing (4).

## I.2.2 Rim Seal Assembly Fire Test.

**I.2.2.1** A sample representative of the entire roof assembly shall be subjected to a prolonged duration rim seal fire of not less than 60 minutes to ascertain the resilience/fire resistance of the assembly.

**I.2.2.2** The test sequence shall be as outlined in Table I.2.2.2.

## I.3 Measurements/Observations.

**I.3.1** The following tests and measurements shall be recorded:

- (1) Complete dimensions of roof and roof assembly samples
- (2) Complete description of roof construction and roof assembly construction, including seal type and whether primary, secondary, or both
- (3) A video and photographic record
- (4) Water layer depths and temperatures
- (5) Fuel layer depths and temperatures
- (6) Ambient temperature
- (7) Wind speed
- (8) Other weather data such as humidity and wind direction
- (9) Foam solution application rate for foam application during roof test
- (10) Foam quality — expansion and 25 percent drainage time
- (11) Foam layer depth
- (12) Foam type used and degree of aspiration

**I.3.2** Recording the following measurements shall be optional:

- (1) Spot temperatures of the following suggested roof samples or roof assembly using thermocouples:
  - (a) Roof deck
  - (b) Roof slab
  - (c) Seal
  - (d) Foam dam
  - (e) Tank shell
- (2) Radiant heat measurement using radiometers
- (3) Thermal observations using a thermal imaging camera

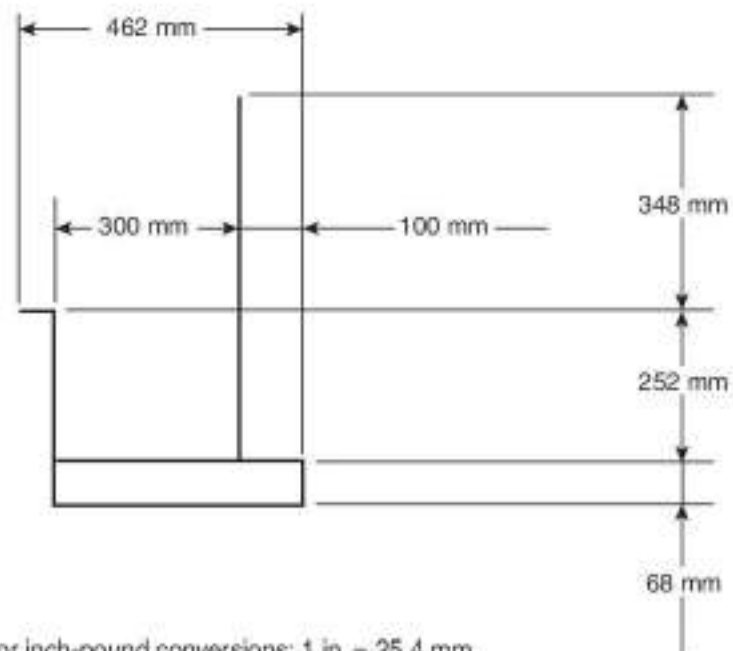
## I.4 Performance Criteria.

**I.4.1** This section shall establish suitable performance criteria for the roofs or roof assemblies under test.

**I.4.2** The test shall be terminated when the fire stops.



FIGURE I.1.3.2.2(e) Typical Roof Assembly Sample Dimensions for Rim Seal Test (1).



For inch-pound conversions: 1 in. = 25.4 mm.

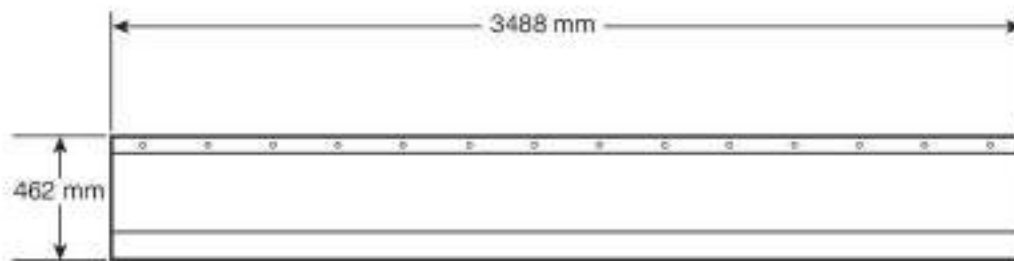
FIGURE I.1.3.2.2(f) Typical Roof Assembly Sample Dimensions for Rim Seal Test (2).

## I.4.3 Roof Test.

**I.4.3.1** The roof test determines the fire resistance of only the roof, not the roof and seal assembly.

**I.4.3.2** Pass criteria shall be as follows:

- (1) There is no damage to the roof sample and roof integrity is maintained when the fuel is completely burned off.
- (2) Roof sample remains buoyant and in full contact with the liquid surface once the fuel is completely burned off.
- (3) Where the roof sample is joined or covered by metal plates, no distortion is observed that could trap flammable vapors.



For inch-pound conversions: 1 in. = 25.4 mm.

**FIGURE I.1.3.2.2(g) Typical Roof Assembly Sample Dimensions for Rim Seal Test (3).**

- (4) No sustained flaming or glowing over the roof sample is observed once the fuel is completely burned off.
- (5) No adhesion between the steel pad on the strut holding the roof in position and the roof is found.
- (6) Central hole does not to exceed 625 mm (25 in.) diameter at the top surface of the roof once the fuel is completely burned off.
- (7) Foam travels smoothly around the circumference and on the top of the roof and the minimum depth of the foam blanket is 150 mm (6 in.). Roof sample remains buoyant after foam is applied.

#### I.4.4 The Assembly Test.

**I.4.4.1** The assembly test shall determine the integrity of the assembly sample.

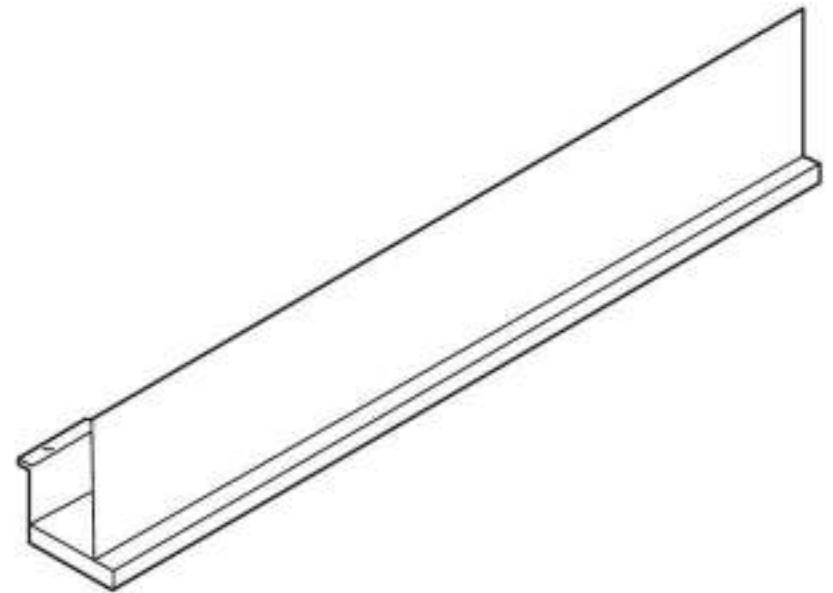
**I.4.4.2** Pass criteria shall be as follows:

- (1) No damage to the primary seal that allow vapors to escape freely is observed.
- (2) No damage to the roof part of the assembly is observed.
- (3) Foam dam maintains its integrity.
- (4) No sustained flaming or glowing over the assembly sample is observed once the fuel is completely burned off.

#### I.5 Test Report.

**I.5.1** The test report shall contain the following information:

- (1) Number and/or title of test
- (2) Name of the manufacturer and the test sample's place and year of manufacture
- (3) A copy of the technical documentation of the test sample
- (4) Name of the test place and the date of the test
- (5) A unique test report number



**FIGURE I.1.3.2.2(h) Typical Roof Assembly Sample Dimensions for Rim Seal Test (4).**

- (6) Weather conditions measurement made during the test
- (7) A description of the damage or deformation arising in the test sample after the test is conducted in accordance with the performance criteria and whether the integrity of the sample was maintained
- (8) Any pertinent observations made before, during, or after the test
- (9) Photographs taken before, during, and after the test

**I.5.2** The test report shall contain a statement that the results obtained relate only to the sample tested.

**I.5.3** The test report shall not be considered a certificate of conformity.

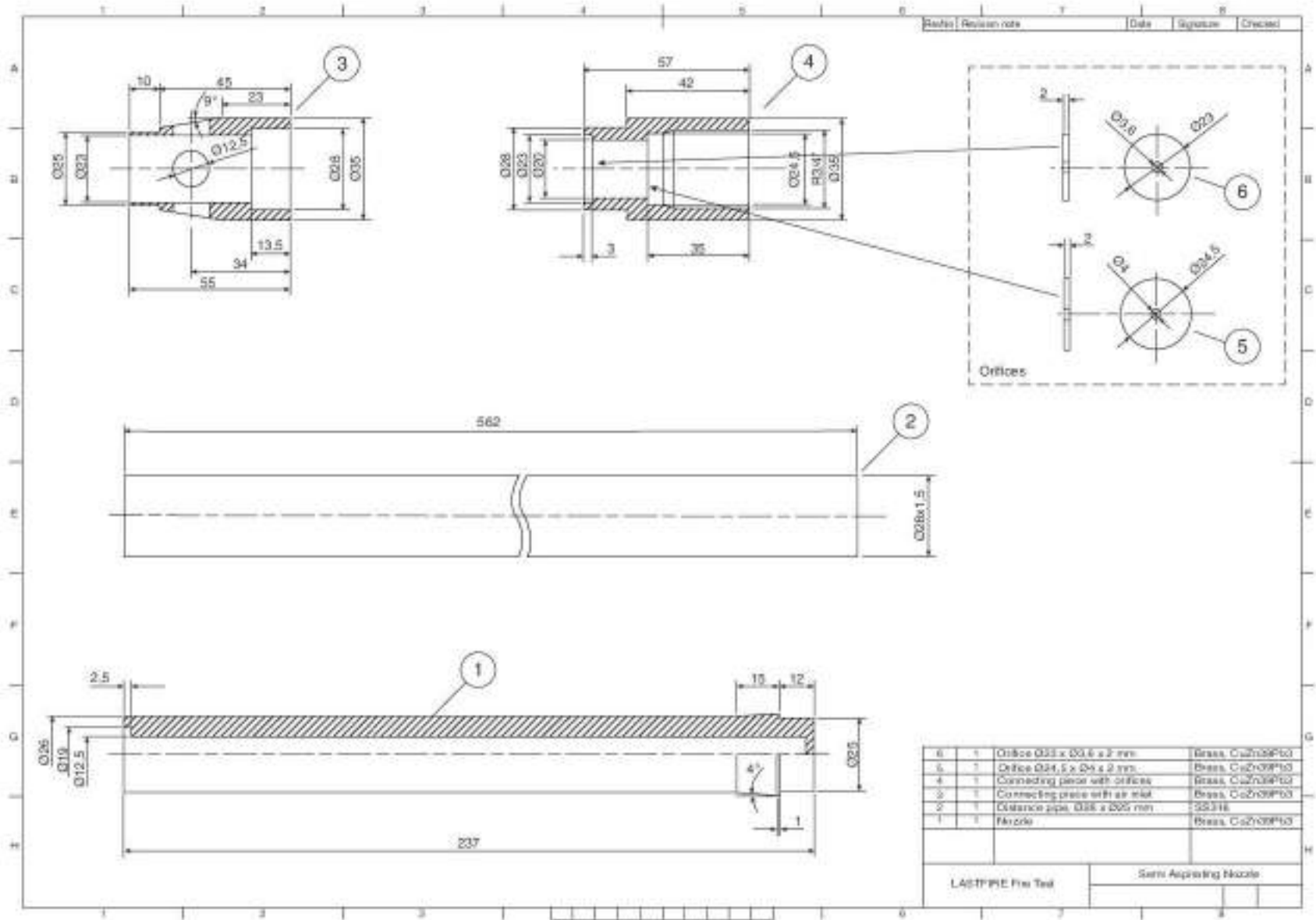
Table I.2.1.3 Roof Test Sequence

Sequence	Activity	Comments/Observations
1	Ensure the test tank is clean and in good order for the test.	
2	Fill the pan with water to approximately 150 mm (water to act as substrate for fuel).	
3	Place the roof module in the test pan, ensuring the roof is positioned correctly and is central within the pan.	
4	Add fuel (heptane) to the test pan. (NOTE: 2 × 200 L/2 × 55 USG drums should be sufficient.) The fuel should be added until the roof floats on 25 mm of fuel.	Test pan area = 4.67 m <sup>2</sup> 600 mm dia. penetration area = 0.283 m <sup>2</sup> Fuel depths/amounts = (2 × 0.025 m) × 4.67 m <sup>2</sup> = 0.234 m <sup>3</sup> 0.068 m (penetration) × 0.283 m <sup>2</sup> = 0.0192 m <sup>3</sup> Rim areas = (0.15 m × 0.118) × 2 = 0.0354 m <sup>3</sup> Total fuel quantity = 0.289 m <sup>3</sup> or 289 L.
5	Position the holding struts on the roof.	
6	Add the remaining 25 mm of fuel.	There should be 25 mm of heptane on top of the roof deck, and fuel should be exposed around the entire rim circumference. Fuel should also be present in the penetration at the center deck position, throughout the full depth.
7	Ignite the fuel 120 sec ± 5 sec after fuel delivery.	Start test documentation/video and measurements. Video Thermal imaging Spot thermocouples on roof/shell (if used) Radiometers (if used) NOTE: If radiometers are used, the reduction in radiant heat from the fire and hence fire intensity can be gauged from comparison with baseline results during the spill on roof fire portion of the test.
8	Allow spill on roof fire to burn completely.	Record time at which fuel on top of the roof is consumed by fire.
9	Continue fire test — allow fuel in center penetration and at rim to burn freely.	Record time of transition to center penetration burning and observe behavior.
10	Allow the fire to burn for a minimum of 120 minutes or until cessation of fire test (whichever is reached first).	Cessation of the fire test can be brought about if, in the opinion of the test directors, the roof has failed to survive prolonged burning and it would not be in the general interest to prolong the test. (However, useful observations can be made regarding the fire behavior and survivability of the roof even if fire performance is reduced.) The final decision to cease testing rests with the test directors.
11	Discharge foam onto the roof using a small-scale semi-aspirating foam nozzle* for a period of at least 5 minutes.	The purpose of this is to assess the roof's ongoing stability during fire conditions when a dynamic load (semi-aspirated foam solution with typical expansion ratio of 4:1) is applied to the deck. The foam solution should be applied at a rate of at least 3.5 L/min/m <sup>2</sup> for a minimum of 5 minutes. It is recognized that normally foam would be applied in this way to a full surface fire and not necessarily a rim seal fire, but the purpose is to assess roof stability only. The test directors should determine a suitable protocol step for assessing this along with suitable criteria for stability.

For inch-pound conversions: 1 m = 3.28 ft, 1 L = 0.26 gal, 1 L/min/m<sup>2</sup> = 0.025 gpm/ft<sup>2</sup>.

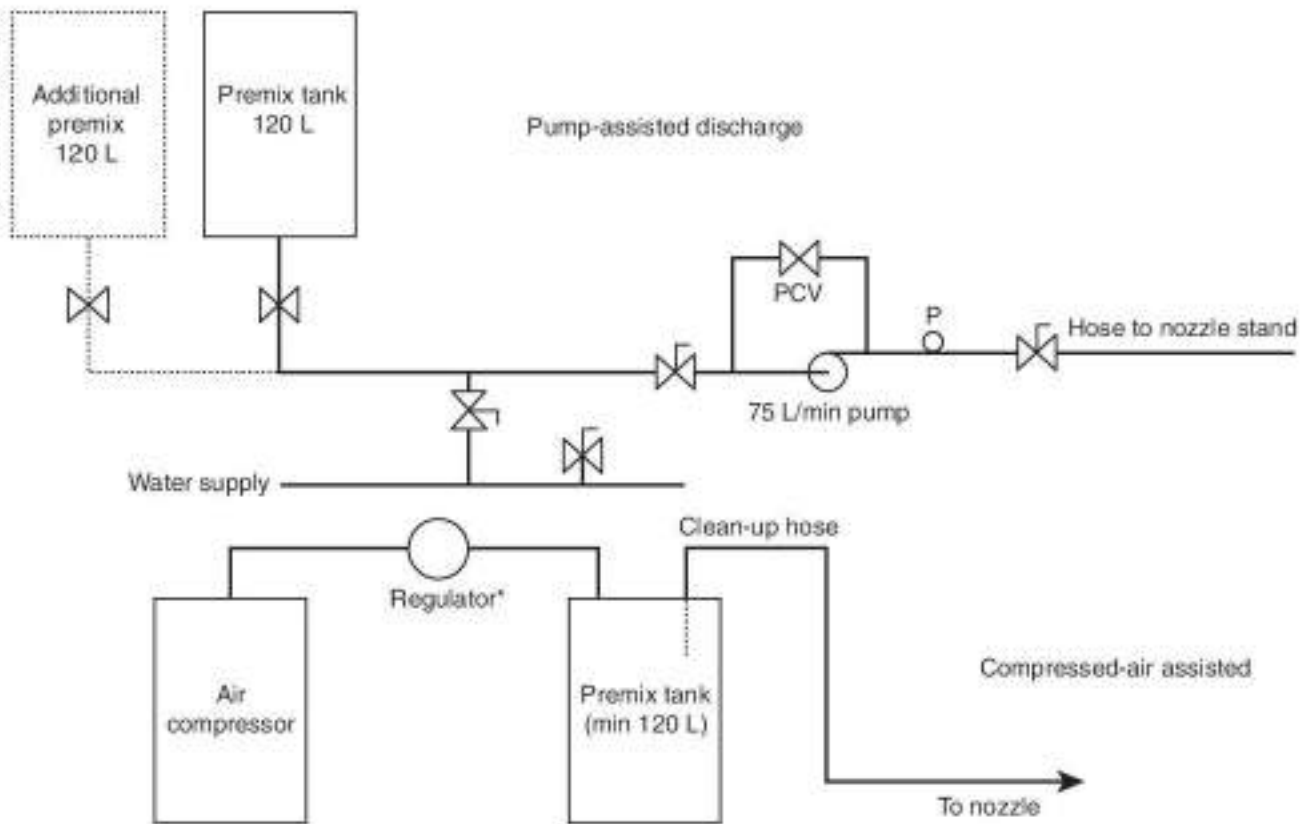
\*Other available nozzles include an aspirating nozzle (typically 3.5 L/min/m<sup>2</sup> foam solution application rate) and a system nozzle (2.5 L/min/m<sup>2</sup>). These rates are just over one-half this standard's recommended rates. The test directors should establish a suitable rate and nozzle combination for application to ensure that the roof stability test is a credible one.

See Figure I.2.1.3(a) for a drawing of a typical semi-aspirating nozzle setup and Figure I.2.1.3(b) for schematic of foam delivery system.



For inch-pound conversions: 1 in. = 25.4 mm.

FIGURE I.2.1.3(a) Semi-aspirating Foam Nozzle for Foam Application/Roof Load Test.



\*e.g., Nullmatic pressure regulator 3-200 psig range. Approximately 110 psig for aspirating (4 USG) nozzle/85 psig for system nozzle.

**FIGURE I.2.1.3(b) Foam Delivery Schematic.**



**Table I.2.2.2 Rim Seal Assembly Fire Test Sequence**

Sequence	Activity	Comments/Observations
1	Ensure the test rig is clean and in good order for the test.	
2	Place the roof assembly in the test rig.	Roof assembly comprises the following: Roof deck: 3 m (9.8 ft) (L) 400 mm (15.75 in.) (W) 68 mm (2.68 in.) (D) Seal: Affixed to roof slab and designed to cover (ideally) the 200 mm rim gap but should be no less than 150 mm. Foam dam: 600 mm (2 ft) (H) 100 mm (4 in.) from roof edge NOTE: A 25 mm gap is provided on each side of the roof to allow for a ventilation-controlled rim seal fire.
3	Float 30 L of water into the fuel well/rig leg (seal area) to act as substrate.	To provide a depth of 150 mm of water.
4	Place 75 L of fuel into the fuel well/rig leg (seal area).	Depth of fuel should be in the order of 360 mm (approximately 14 in.) NOTE: This fuel amount is anticipated to be enough for at least a 60-minute burn. Fuel quantity/burn time can be adjusted at the discretion of the test directors during this development series.
5	Adjust water level to ensure fuel reaches topside of rim/underside of roof sample on the test rig.	The fuel level should reach the roof slab bounded by the 20 mm rim at the underside of the sample.
6	Ignite the fuel 120 sec $\pm$ 5 sec after fuel delivery.	Start test documentation/video and measurements. Video Thermal imaging Spot thermocouples on roof/shell (if used) Radiometers (if used) NOTE: If radiometers are used, the reduction in radiant heat from the fire and hence fire intensity can be gauged from comparison with baseline results during the spill on roof fire portion of the test.
7	Allow the rim seal fire to burn freely.	Monitor the fire burning characteristics.
8	Continue fire test — allow fuel in fuel well/rim seal area to burn freely.	Observe behavior of the roof, rim, and foam dam assembly under rim seal fire conditions and record state at 5, 10, 20, 30, 45, and 60 minutes.
9	Allow fire to burn until all the fuel is burned off.	Cessation of the fire test can be brought about if, in the opinion of the test directors, the assembly has failed to survive prolonged burning and it would not be in the general interest to prolong the test. (However, useful observations can be made regarding the fire behavior and survivability of the assembly even if fire performance is reduced.) The final decision to cease testing rests with the test directors.

For inch-pound conversions: 1 in. = 25.4 mm; 1 L = 0.26 gal.

## Annex J Informational References

**J.1 Referenced Publications.** The documents or portions thereof listed in this annex are referenced within the informational sections of this standard and are not part of the requirements of this document unless also listed in Chapter 2 for other reasons.

**J.1.1 NFPA Publications.** National Fire Protection Association, 1 Batterymarch Park, Quincy, MA 02169-7471.

NFPA 13, *Standard for the Installation of Sprinkler Systems*, 2019 edition.

NFPA 15, *Standard for Water Spray Fixed Systems for Fire Protection*, 2017 edition.

NFPA 16, *Standard for the Installation of Foam-Water Sprinkler and Foam-Water Spray Systems*, 2019 edition.

NFPA 24, *Standard for the Installation of Private Fire Service Mains and Their Appurtenances*, 2019 edition.

NFPA 25, *Standard for the Inspection, Testing, and Maintenance of Water-Based Fire Protection Systems*, 2020 edition.

NFPA 30, *Flammable and Combustible Liquids Code*, 2021 edition.

NFPA 59A, *Standard for the Production, Storage, and Handling of Liquefied Natural Gas (LNG)*, 2019 edition.

NFPA 70<sup>®</sup>, *National Electrical Code*<sup>®</sup>, 2020 edition.

NFPA 72<sup>®</sup>, *National Fire Alarm and Signaling Code*<sup>®</sup>, 2019 edition.

NFPA 402, *Guide for Aircraft Rescue and Fire-Fighting Operations*, 2019 edition.

NFPA 403, *Standard for Aircraft Rescue and Fire-Fighting Services at Airports*, 2018 edition.

NFPA 409, *Standard on Aircraft Hangars*, 2021 edition.

NFPA 414, *Standard for Aircraft Rescue and Fire-Fighting Vehicles*, 2020 edition.

NFPA 1901, *Standard for Automotive Fire Apparatus*, 2021 edition.

### J.1.2 Other Publications.

**J.1.2.1 AGA Publications.** American Gas Association, 400 North Capitol Street, NW, Washington, DC 20001.

Project IS-3-1. November 15 1973. LNG Spills on Land.

Project IS-100-1. February 1974. An Experimental Study on the Mitigation of Flammable Vapor Dispersion and Fire Hazards Immediately Following LNG Spills on Land.

**J.1.2.2 AIChE Publications.** American Institute of Chemical Engineers, 120 Wall Street, FL 23, New York, NY 10005-4020.

*Guidelines for Safe Warehousing of Chemicals*, Center for Chemical Process Safety, 1998.

**J.1.2.3 API Publications.** American Petroleum Institute, 1220 L Street, NW, Washington, DC 20005-4070.

API STD 650, *Welded Tanks for Oil Storage*, 12th edition, 2013, addendum 3, 2018.

**J.1.2.4 ASTM Publications.** ASTM International, 100 Barr Harbor Drive, P.O. Box C700, West Conshohocken, PA 19428-2959.

ASTM D1141, *Standard Practice for the Preparation of Substitute Ocean Water*, 1998, reapproved 2013.

**J.1.2.5 AWS Publications.** American Welding Society, 8669 36 Street, #130, Miami, FL 33166-6672.

AWS B2.1/B2.1M, *Specification for Welding Procedure and Performance Qualification*, 2014.

**J.1.2.6 FM Publications.** FM Approvals LLC, 1151 Boston-Providence Turnpike, P.O. Box 9102, Norwood, MA 02062

FM Approvals 5130, *Foam Extinguishing Systems*, 2011.

FM Approvals 5138, *Assessment Standard for Proportioning Testing*, April 2011.

**J.1.2.7 IEEE Publications.** IEEE, Three Park Avenue, 17th Floor, New York, NY 10016-5997.

IEEE 45, *Recommended Practice for Electric Installations on Shipboard*, 2002.

**J.1.2.8 IMO Publications.** International Maritime Organization, 4 Albert Embankment, London SE1 7SR, United Kingdom.

IBC Code, *International Code for the Construction and Equipment of Ships Carrying Dangerous Chemicals in Bulk*, 2007.

*Safety of Life at Sea (SOLAS)*, Regulation 61, Chapter 212.

**J.1.2.9 ISO Publications.** International Organization for Standardization, ISO Central Secretariat, BIBC II, Chemin de Blandonnet 8, CP 401, 1214 Vernier, Geneva, Switzerland.

ISO 9001, *Quality Management Systems—Requirements*, 2008.

**J.1.2.10 TC Publications.** Transport Canada, 330 Sparks Street, Ottawa, ON K1A 0N5, Canada.

TP 127 E, *Ships Electrical Standards*, Revision 02, May 2018.

**J.1.2.11 UL Publications.** Underwriters Laboratories Inc., 333 Pfingsten Road, Northbrook, IL 60062-2096.

UL 139, *Outline of Investigation for Medium- and High-Expansion Foam-Extinguishing System Equipment and Concentrates*, 2018.

UL 162, *Foam Equipment and Liquid Concentrates*, 2018.

**J.1.2.12 U.S. Government Publications.** U.S. Government Publishing Office, Washington, DC 20402.

Comprehensive Environmental Response Compensation and Liability Act (CERCLA), 42 U.S.C. 1906 et seq.

Federal Specification O-F-555C, *Foam Liquid, Fire Extinguishing Mechanical* (out of print).

Federal Specification VV-G-1690, "Gasoline, Automotive, Leaded or Unleaded," 1989.

Federal Register Volume 60, Issue 112, pp. 30926-30962, July 12, 1995.

U.S. Coast Guard Navigation and Vessel Inspection Circulars. 1982. NVIC 11-82, *Deck Foam Systems for Polar Solvents*.

**J.1.2.13 Other Publications.**

Conch Methane Services, Ltd. 1962. "Liquefied Natural Gas/Characteristics and Burning Behavior."

Gremeles, A. E., and E. M. Drake. October 1975. "Gravity Spreading and Atmospheric Dispersion of LNG Vapor Clouds." Jacksonville, FL: Fourth International Symposium on Transport of Hazardous Cargoes by Sea and Inland Waterways.

Humbert-Basset, R. and A. Montet. September 1972. "Flammable Mixture Penetration in the Atmosphere from Spillage of LNG." Washington, DC: Third International Conference on LNG.

Johnson, D. W., et al., *Control and Extinguishment of LPG Fires*, Applied Technology Corp., DOEEV-6020-1, August 1980.

LASTFIRE Foam Position Paper, LASTFIRE, Issue 2, October 2016.

*LASTFIRE Ongoing Testing of New Generation Foams DFW Large Scale Extended Flow Test Report*, LASTFIRE, November 2018.

Mine Safety Appliances Research Corp. "LNG Vapor Concentration Reduction and Fire Control with MSAR High Expansion Foam." Evans City, PA.

*The Montreal Protocol on Substances that Deplete the Ozone Layer*, United Nations Environment Programme, Nairobi, Kenya, 2000.

Persson, H., et al., *ETANKFIRE – Fire extinguishing tests of ethanol tank fires in reduced scale*, SP Technical Institute of Sweden, 2016.

Schneider, A. L. December 1978. *Liquefied Natural Gas Safety Research Overview*. Springfield, VA: National Technical Information Service.

Welker, J. et al. January 1976. "Fire Safety Aboard LNG Vessels."

Wesson, H. R., J. R. Welker, and L. E. Brown. December 1972. "Control LNG Spill Fires." *Hydrocarbon Processing*.

**J.2 Informational References.** The following documents or portions thereof are listed here as informational resources only. They are not a part of the requirements of this document.

U.S. Coast Guard Navigation and Vessel Inspection Circulars. 1992. *Guidance for Acceptance of the National Board of Boiler and Pressure Vessel Inspectors (NBBI) National Board Inspection Code (NBIC) for Repairs and Alterations to Boilers and Pressure Vessels*.

**J.3 References for Extracts in Informational Sections.**

NFPA 13, *Standard for the Installation of Sprinkler Systems*, 2019 edition.

NFPA 16, *Standard for the Installation of Foam-Water Sprinkler and Foam-Water Spray Systems*, 2019 edition.

NFPA 30, *Flammable and Combustible Liquids Code*, 2018 edition.

## Index

Copyright © 2020 National Fire Protection Association. All Rights Reserved.

The copyright in this index is separate and distinct from the copyright in the document that it indexes. The licensing provisions set forth for the document are not applicable to this index. This index may not be reproduced in whole or in part by any means without the express written permission of NFPA.

### -A-

#### Acceptance Testing, Chap. 12

- Acceptance Tests, 12.3, A.12.3
- Acceptance Tests of Foam-Water Deluge and Spray Systems, 12.9
  - Flushing of Supply Piping, 12.9.1, A.12.9.1
  - General Information Sign, 12.9.7, A.12.9.7
  - Hydraulic Design Information Sign, 12.9.6
  - Hydrostatic Pressure Tests, 12.9.2
    - Underground Piping Systems, 12.9.2.2
  - Instructions, 12.9.5
  - Proportioning System Testing, 12.9.4, A.12.9.4
    - Flushing the System, 12.9.4.3
    - Rate of Discharge, 12.9.4.2
  - System Tests Discharging Foam from Foam-Water Deluge and Spray Systems, 12.9.3
    - Acceptance Tests, 12.9.3.1, A.12.9.3.1
      - Approval of Systems, 12.9.3.1.1
- Approval of Low-, Medium-, and High-Expansion Foam Systems, 12.7
- Discharge Tests, 12.6, A.12.6
- Flushing after Installation, 12.2
- Inspection and Visual Examination, 12.1
- Operating Tests, 12.5
  - Operating Test for Control Valves, 12.5.5
  - Water Supply Test, 12.5.4
- Pressure Tests, 12.4
- System Restoration, 12.8

#### Approved

- Definition, 3.2.1, A.3.2.1

#### Authority Having Jurisdiction (AHJ)

- Definition, 3.2.2, A.3.2.2

### -C-

#### Combustible Liquid

- Class II Liquid
  - Definition, 3.3.1.1
- Class IIIA Liquid
  - Definition, 3.3.1.2
- Class IIIB Liquid
  - Definition, 3.3.1.3
- Definition, 3.3.1

#### Compressed Air Foam Systems, Chap. 8

- Air or Nitrogen Supply, 8.4

- Air Compressor, 8.4.6
- Plant Air, 8.4.5
- Quantity, 8.4.1
  - Primary Supply, 8.4.1.1
  - Reserve Supply, 8.4.1.2
- Regulators, 8.4.4
- Storage Containers, 8.4.2
- Supervision, 8.4.3
- CAFS Discharge Device Choice and Location, 8.14
- Compressed Air Foam Discharge Devices, 8.7
- Compressed Air Foam-Generating Method, 8.5
- Discharge Density, 8.15
- Discharge Duration, 8.16
- Distribution Systems, 8.6
  - Fittings, 8.6.2
  - Piping, 8.6.1
- Foam Concentrate, 8.3
  - Compatibility of Foam Concentrate, 8.3.6
  - Quality, 8.3.1
  - Quantity, 8.3.2
  - Reserve Supply of Foam Concentrate, 8.3.5
  - Storage Conditions, 8.3.4
  - Storage Tanks, 8.3.3
- General, 8.1
- Installation of Automatic Detection, 8.13
- Installation of Piping and Fittings, 8.12
- Limitations, 8.10
- Maintenance, 8.20
- Operation and Control of Systems, 8.8
- Plans and Specifications, 8.18
- System Design, 8.11
- System Flow Calculation, 8.17
  - General, 8.17.1
- System Types, 8.9
- Testing and Acceptance, 8.19
- Water Supplies, 8.2
  - Design, 8.2.5
  - Pressure, 8.2.3
  - Quality, 8.2.1
  - Quantity, 8.2.2
  - Storage, 8.2.6
  - Temperature, 8.2.4

#### Concentration

- Definition, 3.3.2, A.3.3.2

### -D-

#### Definitions, Chap. 3

#### Discharge Devices

- Air-Aspirating Discharge Devices
  - Definition, 3.3.3.1

- Compressed Air Foam Discharge Devices
  - Definition, 3.3.3.2
  - Definition, 3.3.3, A.3.3.3
- Non-Air-Aspirating Discharge Devices
  - Definition, 3.3.3.3, A.3.3.3.3
- Discharge Outlet**
  - Definition, 3.3.4
  - Fixed Foam Discharge Outlet
    - Definition, 3.3.4.1
  - Type I Discharge Outlet
    - Definition, 3.3.4.2, A.3.3.4.2
  - Type II Discharge Outlet
    - Definition, 3.3.4.3
- E-**
- Eductor (Inductor)**
  - Definition, 3.3.5, A.3.3.5
  - In-Line Eductor
    - Definition, 3.3.5.1, A.3.3.5.1
- Expansion**
  - Definition, 3.3.6
- Explanatory Material, Annex A**
- F-**
- Film Formation**
  - Definition, 3.3.7
- Fire**
  - Class A Fire
    - Definition, 3.3.8.1
  - Class B Fire
    - Definition, 3.3.8.2
    - Definition, 3.3.8
- Flammable (Class I) Liquid**
  - Class IA Liquid
    - Definition, 3.3.9.1
  - Class IB Liquid
    - Definition, 3.3.9.2
  - Class IC Liquid
    - Definition, 3.3.9.3
  - Definition, 3.3.9
- Foam**
  - Compressed Air Foam (CAF)
    - Definition, 3.3.10.1
    - Definition, 3.3.10, A.3.3.10
- Foam Chamber**
  - Definition, 3.3.11
- Foam Concentrate**
  - Alcohol-Resistant Foam Concentrate
    - Definition, 3.3.12.1, A.3.3.12.1
  - Aqueous Film-Forming Foam Concentrate (AFFF)
    - Definition, 3.3.12.2, A.3.3.12.2
    - Definition, 3.3.12, A.3.3.12
  - Film-Forming Fluoroprotein Foam Concentrate (FFFP)
    - Definition, 3.3.12.3, A.3.3.12.3
  - Film-Forming Foam
    - Definition, 3.3.12.4
  - Fluoroprotein Foam Concentrate
    - Definition, 3.3.12.5, A.3.3.12.5
  - Medium- and High-Expansion Foam Concentrate
    - Definition, 3.3.12.6, A.3.3.12.6
  - Protein Foam Concentrate
    - Definition, 3.3.12.7, A.3.3.12.7
  - Synthetic Fluorine-Free Foam (SFFF)
    - Definition, 3.3.12.8, A.3.3.12.8
  - Synthetic Foam Concentrate
    - Definition, 3.3.12.9
- Foam Concentrate Quality, Annex G**
  - Fire Performance Test for Class B Materials, G.3
  - Fire Performance Test for Class A Materials, G.1
  - Quality Control Test, G.2
  - Standard Evaluation Test of High-Expansion Foam Systems for LNG Fires, G.4
- Foam Concentrate Type**
  - Definition, 3.3.13
- Foam Generators**
  - Definition, 3.3.14
  - Foam Generators — Aspirator Type
    - Definition, 3.3.14.1
  - Foam Generators — Blower Type
    - Definition, 3.3.14.2, A.3.3.14.2
- Foam Health, Safety, and Environmental Issues, Annex E**
  - Discharge Scenarios, E.2
    - Firefighting Operations, E.2.1
    - Fixed System Releases, E.2.4
    - System Tests, E.2.3
    - Training, E.2.2
  - Fixed Systems, E.3
    - Facilities with Engineered Containment, E.3.2
    - Facilities Without Engineered Containment, E.3.1
    - New Facilities, E.3.3
  - General, E.1
- Foam Injection**
  - Definition, 3.3.15
  - Semisubsurface Foam Injection
    - Definition, 3.3.15.1
  - Subsurface Foam Injection
    - Definition, 3.3.15.2
- Foam Solution**
  - Definition, 3.3.16, A.3.3.16
  - Premixed Foam Solution
    - Definition, 3.3.16.1
- Foam System Types**
  - Compressed Air Foam System (CAFS)
    - Definition, 3.3.17.1, A.3.3.17.1
  - Definition, 3.3.17
  - Fixed Systems
    - Definition, 3.3.17.2
  - Mobile System
    - Definition, 3.3.17.3, A.3.3.17.3
  - Portable System
    - Definition, 3.3.17.4
  - Semifixed System
    - Definition, 3.3.17.5, A.3.3.17.5

**Foam-Generating Methods**

Compressed Air Foam-Generating Method

Definition, 3.3.18.1, A.3.3.18.1

Definition, 3.3.18, A.3.3.18

**Foam-Water Density**

Definition, 3.3.19

**-H-****Handline**

Definition, 3.3.20, A.3.3.20

**-I-****Inductor**

Definition, 3.3.21

**Informational References, Annex J****Inspection, Testing, and Maintenance**

Definition, 3.3.22

Inspection

Definition, 3.3.22.1

Maintenance

Definition, 3.3.22.2

Test

Definition, 3.3.22.3

Testing

Definition, 3.3.22.4

**Inspection, Testing, and Maintenance, Chap. 13**

Foam-Water Sprinkler Systems, 13.3

Component Action Requirements, 13.3.5

General, 13.3.1

Hangers, Braces, and Supports, 13.3.1.5

Impairments, 13.3.1.3

Obstruction Investigations, 13.3.1.2

System Piping and Fittings, 13.3.1.4

Inspection, 13.3.2

Drainage, 13.3.2.4

Foam-Water Discharge Devices, 13.3.2.1, A.13.3.2.1

Proportioning Systems, 13.3.2.5, A.13.3.2.5

Strainers, 13.3.2.3

Water Supply, 13.3.2.2

Maintenance, 13.3.4, A.13.3.4

Bladder Tank Proportioner, 13.3.4.5

Foam Components, 13.3.4.3

Foam Concentrate Samples, 13.3.4.2

In-Line Balanced Pressure Proportioner, 13.3.4.8

Corrosion and Sediment, 13.3.4.8.4

Flushing, 13.3.4.8.3

Pump Operation, 13.3.4.8.1

Servicing, 13.3.4.8.2

Line Proportioner, 13.3.4.6

Pressure Vacuum Vents, 13.3.4.9

Standard Balanced Pressure Proportioner, 13.3.4.7

Corrosion and Sediment, 13.3.4.7.4

Flushing, 13.3.4.7.3

Pump Operation, 13.3.4.7.1

Servicing, 13.3.4.7.2

Standard Pressure Proportioner, 13.3.4.4

Operational Tests, 13.3.3, A.13.3.3

Concentration Testing, 13.3.3.5

Manual Actuation Devices, 13.3.3.4

Multiple Systems, 13.3.3.3

Operational Test Performance, 13.3.3.2, A.13.3.3.2

Discharge Patterns, 13.3.3.2.6

Discharge Time, 13.3.3.2.5

Pressure Readings, 13.3.3.2.7, A.13.3.3.2.7

Response Time, 13.3.3.2.4

Test Preparation, 13.3.3.1, A.13.3.3.1

General, 13.1

Minimum Requirements, 13.1.1

Other System Components, 13.1.2

Low-, Medium-, and High-Expansion Foam Systems, 13.2

Detection and Actuation Equipment, 13.2.5

Foam Concentrate Inspection, 13.2.6

Foam-Producing Equipment, 13.2.2, A.13.2.2

Compressed Air Foam-Producing Equipment, 13.2.2.4

General, 13.2.1, A.13.2.1

High-Pressure Cylinders, 13.2.7

Operating Instructions and Training, 13.2.8

Piping, 13.2.3

Strainers, 13.2.4

**Installation Requirements, Chap. 10**

Flushing, 10.2

Foam Concentrate Pumps, 10.1

Hangers, Supports, and Protection for Pipework, 10.6

Hose Requirements, 10.7

Low-Expansion System Piping, 10.4

Power Supply, 10.3

Controller, 10.3.3

Service Disconnecting Means, 10.3.4, A.10.3.4

Test Connections, 10.8

Valves in Low-Expansion Systems, 10.5

Bladder Tank Valves, 10.5.7, A.10.5.7

**-L-****Labeled**

Definition, 3.2.3

**Listed**

Definition, 3.2.4, A.3.2.4

**Low-Expansion Foam Sprinkler and Spray Systems, Chap. 6**

Acceptance Tests, 6.6

Administration, 6.1

Application, 6.1.3

Purpose, 6.1.2, A.6.1.2

Scope, 6.1.1

General System Requirements, 6.2

Approvals, 6.2.6

Foam Discharge Duration, 6.2.3

General System Information, 6.2.1

Preprimed Systems, 6.2.5, A.6.2.5

Reserve Supply of Foam, 6.2.4, A.6.2.4

Types of Systems, 6.2.2

Inspection, Testing, and Maintenance, 6.7

System Components, 6.4

Approved Devices and Materials, 6.4.1

Automatic System Detection, 6.4.9

- Discharge Devices, 6.4.2
- Foam Concentrate, 6.4.3, A.6.4.3
- Foam Concentrate Proportioning Means, 6.4.4
- Foam Concentrate Pumps, 6.4.5, A.6.4.5
- Foam Concentrate Storage Tanks, 6.4.6
- Piping, Valves, Pipe Fittings, and Hangers, 6.4.7
- Stock of Spare Sprinklers, 6.4.11
- Strainers for Foam Concentrate, 6.4.8
- Test Connections, 6.4.10, A.6.4.10
- System Design and Installation, 6.5
  - Alarms, 6.5.4
  - Design Criteria, 6.5.2
    - Containment, Drainage, and Spill Control, 6.5.2.6
    - Design Approach, 6.5.2.2, A.6.5.2.2
      - Foam-Water Wet Pipe, Dry Pipe, and Preaction Systems, 6.5.2.2.2
        - Total Design Area, 6.5.2.2.2.1
    - Foam Concentrate Lines, 6.5.2.5
    - Foam Solution Discharge Duration, 6.5.2.3
    - Proportioning System, 6.5.2.4
      - Power Supply and Controller, 6.5.2.4.2
    - Referenced Standards, 6.5.2.1, A.6.5.2.1
  - Equipment Location, 6.5.3
  - Fire Department Connection, 6.5.9
  - Foam-Water Deluge Systems, 6.5.8
    - Foam Concentrate Injection, 6.5.8.2
    - Tripping, 6.5.8.1
  - General, 6.5.1
  - Hydraulic Calculations, 6.5.10
    - Foam-Water Deluge Systems, 6.5.10.1
    - Foam-Water Wet Pipe, Dry Pipe, and Preaction Systems, 6.5.10.2
    - Friction Loss, 6.5.10.3
  - Sprinkler Spacing and Location, 6.5.6
  - Strainers, 6.5.5
  - Temperature Rating, 6.5.7
  - Working Plans, 6.3
- Low-Expansion Foam Systems for Marine Applications, Chap. 11**
  - Fixed Low-Expansion Foam Systems for Machinery Spaces, 11.2
    - Controls, 11.2.8
  - Fixed Low-Expansion Foam Systems on Deck for Petroleum and Chemical Tankers, 11.3
    - Control Station, 11.3.2
    - Discharge Duration, 11.3.5
    - Fire Main Capacity, 11.3.3, A.11.3.3
    - Purpose, 11.3.1, A.11.3.1
    - Rate of Application, 11.3.4, A.11.3.4
  - Foam Outlet Devices, 11.4, A.11.4
  - Foam System Concentrate Storage, 11.11
  - General, 11.1, A.11.1
    - Components, 11.1.3, A.11.1.3
  - Hand Hose Lines, 11.6
  - Hangers, Supports, and Protection of Pipework, 11.9
  - Hydraulic Calculations, 11.7
  - Isolation Valves, 11.8
  - Monitors, 11.5
    - Monitors, 11.5.7
  - Piping Materials, 11.13
  - Supply Arrangements, 11.12
  - Testing and Inspection, 11.10
- Low-Expansion Foam Tank, Fueling, and Spill Area Systems, Chap. 5**
  - Diked Areas — Outdoor, 5.7, A.5.7
    - Diked Areas Involving Flammable or Combustible Liquids Requiring Alcohol-Resistant Foams, 5.7.4
    - Methods of Application, 5.7.3
      - Fixed Foam Discharge Outlets, 5.7.3.3, A.5.7.3.3
      - Fixed Foam-Water Sprinklers or Nozzles, 5.7.3.4
      - Fixed Low-Level Foam Discharge Outlets, 5.7.3.5
        - Foam Monitors, 5.7.3.5.4
        - Limitations, 5.7.3.5.3, A.5.7.3.5.3
      - Minimum Application Rates and Discharge Times for Fixed Discharge Outlets on Diked Areas Involving Liquid Hydrocarbons, 5.7.3.2, A.5.7.3.2
  - Indoor Hazards, 5.5
    - Design Criteria for Indoor Storage Tanks Containing Flammable or Combustible Liquids Requiring Alcohol-Resistant Foams, 5.5.4
    - Discharge Outlets, 5.5.2
    - Minimum Discharge Time and Application Rate, 5.5.3
  - Loading Racks, 5.6, A.5.6
    - Design Criteria for Foam Monitor Protection Systems, 5.6.5
      - Areas to Be Protected by Monitor Nozzles, 5.6.5.1, A.5.6.5.1
      - Minimum Application Rates and Discharge Times, 5.6.5.3
    - Design Criteria for Foam-Water Sprinkler Systems, 5.6.4
    - Methods of Protection, 5.6.3
  - Nondiked Spill Areas, 5.8, A.5.8
    - Design Criteria for Protection of Spill Fires Involving Hydrocarbons or Flammable and Combustible Liquids Requiring Alcohol-Resistant Foams, 5.8.1
  - Outdoor Covered (Internal) Floating Roof Tanks, 5.4, A.5.4
  - Outdoor Fixed-Roof (Cone) Tanks, 5.2, A.5.2
    - Basis of Design, 5.2.2
      - Design Criteria for Foam Monitors and Handlines, 5.2.4
        - Design Parameters, 5.2.4.4, A.5.2.4.4
        - Foam Application Rates, 5.2.4.2
          - Flow Considerations, 5.2.4.2.1, A.5.2.4.2.1
        - Limitations, 5.2.4.1
      - Tanks Containing Flammable and Combustible Liquids Requiring Alcohol-Resistant Foams, 5.2.4.3, A.5.2.4.3
    - Design Criteria for Subsurface Application, 5.2.6
      - Foam Discharge Outlet Elevation, 5.2.6.3, A.5.2.6.3
      - Foam Discharge Outlets, 5.2.6.2, A.5.2.6.2
      - Minimum Discharge Times and Application Rates, 5.2.6.5
      - Subsurface Injection Back-Pressure Limitations, 5.2.6.4, A.5.2.6.4
    - Design Criteria for Surface Application with Fixed Foam Discharge Outlets, 5.2.5
      - Design Criteria for Tanks Containing Flammable and Combustible Liquids Requiring Alcohol-Resistant Foams, 5.2.5.3, A.5.2.5.3
        - Minimum Discharge Times and Application Rates, 5.2.5.3.4

- Design Criteria for Tanks Containing Hydrocarbons, 5.2.5.2
  - Minimum Discharge Times and Application Rates, 5.2.5.2.2, A.5.2.5.2.2
  - Fixed Foam Discharge Outlets, 5.2.5.1, A.5.2.5.1
- Limitations, 5.2.3, A.5.2.3
- Semisubsurface Systems, 5.2.7, A.5.2.7
- Supplementary Protection, 5.2.1
- Outdoor Open-Top Floating Roof Tanks, 5.3, A.5.3
  - Fixed Discharge Outlets Design Criteria for Seal Area Protection, 5.3.5
    - Foam Dam Design Criteria, 5.3.5.4
    - Top-of-Seal Method with Foam Dam, 5.3.5.2, A.5.3.5.2
    - Top-of-Seal System Design, 5.3.5.3
      - Below Primary Seal or Weather Shield Method, 5.3.5.3.5
      - Below-the-Seal or Weather Shield System, 5.3.5.3.6
  - Foam Handline Design Criteria for Seal Area Protection, 5.3.6, A.5.3.6
  - Foam Monitor Design Criteria for Seal Area Protection, 5.3.7
  - Methods of Seal Fire Protection, 5.3.4
    - Basis of Design, 5.3.4.3, A.5.3.4.3
    - Supplementary Protection, 5.3.4.2
  - Tank Protection Options, 5.3.1
  - Types of Fires Anticipated, 5.3.3, A.5.3.3
    - Seal Area Protection, 5.3.3.2
    - Subsurface and Semisubsurface Injection, 5.3.3.1
- Supplementary Protection, 5.9, A.5.9
  - Additional Protection, 5.9.1
  - Supplemental Foam Hose Stream Requirements, 5.9.2
- Types of Hazards, 5.1, A.5.1

### -M-

#### Medium- and High-Expansion Foam, Annex C

#### Medium- and High-Expansion Systems, Chap. 7

- Air Supply, 7.9
- Distribution Systems, 7.11
  - Arrangement and Installation of Piping and Fittings, 7.11.2
  - Ducts, 7.11.3
  - Piping and Fittings, 7.11.1
- Foam Applications for Liquefied Natural Gas (LNG), 7.14, A.7.14
  - Foam Discharge Rate per Unit Area, 7.14.2, A.7.14.2
  - Quantity, 7.14.3
    - Foam System Arrangement, 7.14.3.3, A.7.14.3.3
  - System Design Considerations, 7.14.1, A.7.14.1
- Foam Concentrate, 7.8
  - Quality, 7.8.1
- Foam-Generating Apparatus Location, 7.10
  - Accessibility for Inspection and Maintenance, 7.10.1
  - Protection Against Exposure, 7.10.2, A.7.10.2
- General Information and Requirements, 7.1, A.7.1
- Hazards Protected, 7.3, A.7.3
- Local Application Systems, 7.13
  - General Information, 7.13.1
    - Description, 7.13.1.1
    - Uses, 7.13.1.2, A.7.13.1.2
  - General Requirements, 7.13.2

- Hazard Specifications, 7.13.3
  - Extent of Hazard, 7.13.3.1
- Foam Requirements for Flammable and Combustible Liquids and Solids, 7.13.3.3
  - Arrangement, 7.13.3.3.3
  - General, 7.13.3.3.1
  - Quantity, 7.13.3.3.2
  - Location of Hazard, 7.13.3.2, A.7.13.3.2
- Occupant Safety and Rescue Operations, 7.6, A.7.6
  - Electrical Clearances, 7.6.3, A.7.6.3
  - Occupant Evacuation, 7.6.1, A.7.6.1
  - Rescue Operations, 7.6.2, A.7.6.2
- Operation and Control of Systems, 7.7
  - Alarms, 7.7.3
  - Detection of Fires, 7.7.1, A.7.7.1
  - Operating Devices, 7.7.4, A.7.7.4
  - Supervision, 7.7.2
- Portable Foam-Generating Devices, 7.15
  - Equipment Specifications, 7.15.5
    - Electric Power Supply and Connections, 7.15.5.2
    - Hose, 7.15.5.1
  - Foam Requirements, 7.15.4
    - Rate and Duration of Discharge, 7.15.4.1
      - Simultaneous Use of Portable Foam-Generating Devices, 7.15.4.1.3
  - General Information, 7.15.1
    - Description, 7.15.1.1
    - General Requirements, 7.15.1.2
  - Hazard Specifications, 7.15.2
  - Location and Spacing, 7.15.3
  - Training, 7.15.6, A.7.15.6
- Systems Protecting One or More Hazards, 7.5
- Total Flooding Systems General Information, 7.12
  - Applications, 7.12.2, A.7.12.2
  - Description, 7.12.1
  - Foam Requirements, 7.12.5
    - Foam Depth, 7.12.5.2
      - High-Expansion Foam, 7.12.5.2.1
      - Medium-Expansion Foam, 7.12.5.2.2
    - General, 7.12.5.1
  - General Requirements, 7.12.3
  - Maintenance of Submergence Volume for High-Expansion Foam, 7.12.10, A.7.12.10
    - Distribution, 7.12.10.5
    - Method, 7.12.10.3
    - Overhaul, 7.12.10.4, A.7.12.10.4
  - Quantity, 7.12.9
  - Rate of Discharge, 7.12.8, A.7.12.8
    - High-Expansion Foam, 7.12.8.2
      - Calculation, 7.12.8.2.3
    - Medium-Expansion Foam, 7.12.8.1
  - Submergence Time for High-Expansion Foams, 7.12.7
  - Submergence Volume for High-Expansion Foams, 7.12.6
  - Total Flooding Enclosure Specifications, 7.12.4
    - Leakage, 7.12.4.1, A.7.12.4.1
      - Openings, 7.12.4.1.1
      - Ventilation, 7.12.4.1.2
- Types of Systems, 7.4



- Use and Limitations, 7.2
- Monitor**
  - Definition, 3.3.23
  - Fixed Monitor (Cannon)
    - Definition, 3.3.23.1, A.3.3.23.1
  - Portable Monitor (Cannon)
    - Definition, 3.3.23.2
- N-**
- Nozzle**
  - Definition, 3.3.24
  - Foam Nozzle or Fixed Foam Maker
    - Definition, 3.3.24.1, A.3.3.24.1
  - Self-Educting Nozzle
    - Definition, 3.3.24.2, A.3.3.24.2
- P-**
- Pressure Foam Maker (High Back Pressure or Forcing Type)**
  - Definition, 3.3.25, A.3.3.25
- Proportioning**
  - Balanced Pressure Pump-Type Proportioning
    - Definition, 3.3.26.1, A.3.3.26.1
  - Coupled Water-Motor Driven Pump Proportioning
    - Definition, 3.3.26.2, A.3.3.26.2
  - Definition, 3.3.26
  - Direct Injection Variable Pump Output Proportioning
    - Definition, 3.3.26.3, A.3.3.26.3
- Proportioning Methods for Foam Systems**
  - Definition, 3.3.27
- Pump Proportioner (Around-the-Pump Proportioner)**
  - Definition, 3.3.28, A.3.3.28
- R-**
- Referenced Publications**, Chap. 2
- Rim Seal Fire Test Protocol**, Annex I
  - Measurements/Observations, I.3
  - Performance Criteria, I.4
    - Roof Test, I.4.3
    - The Assembly Test, I.4.4
  - Test Procedures, I.2
    - Rim Seal Assembly Fire Test, I.2.2
      - Roof Test, I.2.1
  - Test Report, I.5
  - Test Rigs, I.1
    - Roof Test, I.1.2
      - Roof, Seal, and Foam Dam Assembly Test (Rim Seal Fire Test), I.1.3
        - Foam Dam, I.1.3.3
        - Rim Seal, I.1.3.4
        - The Rig, I.1.3.2
- S-**
- Shall**
  - Definition, 3.2.5
- Should**
  - Definition, 3.2.6
- Specifications and Plans**, Chap. 9
  - Approval of Plans, 9.1, A.9.1
  - Plans, 9.3
    - Hydraulic Calculations, 9.3.7
      - Detailed Worksheets, 9.3.7.3
      - General, 9.3.7.1
      - Graph Sheet, 9.3.7.4
      - Summary Sheet, 9.3.7.2
      - Water Supply Analysis, 9.3.7.5
    - Specifications, 9.2
- Spreading Coefficient**
  - Definition, 3.3.30, A.3.3.30
- Standard**
  - Definition, 3.2.7
- Storage Tank Protection Summary**, Annex B
  - Storage Tank Protection Summary Table, B.1
- Storage Tank Roofs**
  - Cone Roof
    - Definition, 3.3.31.1, A.3.3.31.1
  - Definition, 3.3.31
  - External Floating Roof
    - Definition, 3.3.31.2, A.3.3.31.2
  - Internal Floating Roof
    - Definition, 3.3.31.3, A.3.3.31.3
- Stream**
  - Definition, 3.3.29
  - Foam Hose Stream
    - Definition, 3.3.29.1
  - Foam Monitor Stream
    - Definition, 3.3.29.2
- Synthetic Fluorine-Free Foam (SFFF) Research Testing Summary**, Annex H
  - Overview, H.1
  - Testing Conducted by LASTFIRE, H.3
    - General, H.3.1
    - Key Points and Conclusions, H.3.3
    - Report Summary, H.3.2
  - Testing Conducted by the Fire Protection Research Foundation (FPRF), H.2
    - General, H.2.1
    - Key Points and Conclusions, H.2.3
    - Report Summary, H.2.2
- System Components and System Types**, Chap. 4
  - Concentrate Compatibility, 4.4
    - Compatibility of Foam Concentrates, 4.4.1
    - Foam Compatibility with Dry Chemical Agents, 4.4.2, A.4.4.2
  - Foam Concentrate Pumps, 4.6, A.4.6
    - Flushing, 4.6.4
    - Materials, 4.6.1, A.4.6.1
    - Overpressurization, 4.6.3
    - Rated Capacities, 4.6.2
  - Foam Concentrates, 4.3
    - Concentrate Storage, 4.3.2
      - Auxiliary Supplies, 4.3.2.6
      - Foam Concentrate Storage Tanks, 4.3.2.3
        - Atmospheric-Type Storage Tanks, 4.3.2.3.2
        - Pressure-Type Storage Tanks, 4.3.2.3.3
      - Foam Concentrate Supply, 4.3.2.5

- Foam Concentrate Consumption Rates, 4.3.2.5.1
  - Reserve Supply of Foam Concentrate, 4.3.2.5.2
  - Quantity, 4.3.2.2, A.4.3.2.2
  - Storage Conditions, 4.3.2.4
  - Storage Facilities, 4.3.2.1
  - Types of Foam Concentrate, 4.3.1
  - Foam Proportioning, 4.5
    - Fixed Foam Concentrate Proportioning Means, 4.5.2
  - General, 4.1, A.4.1
  - Operation and Control of Systems, 4.9
    - Automatically Actuated Systems, 4.9.2
      - Automatic Detection Equipment, 4.9.2.4, A.4.9.2.4
      - Detection System, 4.9.2.7
    - Equipment, 4.9.4
    - Manually Actuated Systems, 4.9.3
    - Methods of Actuation, 4.9.1
  - Piping, 4.7
    - Fittings, 4.7.3
      - Foam Concentrate Fittings, 4.7.3.1, A.4.7.3.1
      - Foam Solution Fittings, 4.7.3.2
    - Foam Concentrate Pipe Materials, 4.7.1, A.4.7.1
    - Foam Solution Pipe Materials, 4.7.2, A.4.7.2
    - Joining of Pipes and Fittings, 4.7.4
      - Grooved Pipe, 4.7.4.2
      - Threaded Pipe, 4.7.4.1
      - Welded Pipe, 4.7.4.3, A.4.7.4.3
    - Strainers, 4.7.5
    - Valves, 4.7.6, A.4.7.6
      - Valve Supervision, 4.7.6.5, A.4.7.6.5
  - System Types, 4.8
  - Water Supplies, 4.2
    - Fire Department Connections, 4.2.3
    - Water and Foam Concentrate Pumps, 4.2.4
    - Water Supplies for Foam-Water Sprinkler and Spray Systems, 4.2.2
      - Duration, 4.2.2.3
      - Water Quality, 4.2.2.1
      - Water Supply Capacity, Pressure, and Duration, 4.2.2.2
    - Water Supplies for Low-Expansion Foam Tank, Fueling, and Spill Area Systems, 4.2.1
      - Design, 4.2.1.5
      - Pressure, 4.2.1.3
      - Quality, 4.2.1.1, A.4.2.1.1
      - Quantity, 4.2.1.2, A.4.2.1.2
      - Storage, 4.2.1.6
      - Temperature, 4.2.1.4, A.4.2.1.4
- T-
- Tank**
- Balanced Pressure Bladder Tank
    - Definition, 3.3.32.1
  - Definition, 3.3.32
  - Pressure Proportioning Tank
    - Definition, 3.3.32.2, A.3.3.32.2
- Test Method for Marine Firefighting Foam Concentrates Protecting Hydrocarbon Hazards, Annex F**
- Acceptance Criteria, F.5
    - Burnback, F.5.3
      - Method 1, F.5.3.1
      - Method 2, F.5.3.2
    - Fire Performance, F.5.1
    - Sealability, F.5.2
  - Foam Quality, F.6
  - Introduction, F.1
  - Procedures in Case of Failure, F.7
  - Test Apparatus, F.3
    - Conversion Factors, F.3.5
    - Fuel, F.3.3
    - Nozzle, F.3.2
    - Pan, F.3.1
    - Synthetic Sea Water, F.3.4
  - Test Facility, F.2
  - Test Procedure, F.4
    - Burnback, F.4.3
      - Method 1, F.4.3.1
      - Method 2, F.4.3.2
    - Fire Extinguishment, F.4.1
    - Sealability, F.4.2
- Tests for Foam Systems, Annex D**
- Foam Injection Rate Tests, D.5
    - Alternative Test Methods, D.5.3
      - Positive Pressure Pump Direct Injection, D.5.3.2
      - Vehicle Tests, D.5.3.1
    - Test Using Foam Concentrate, D.5.1
    - Tests Using Alternative Listed and Approved Methods, D.5.2
      - General, D.5.2.1
      - Surrogate Liquid Test Method, D.5.2.2
      - Water Equivalency Method, D.5.2.3
  - Foam Solution Concentration Determination, D.2
    - General, D.2.1
      - Conductivity Method, D.2.1.2
        - Equipment, D.2.1.2.1
        - Procedure, D.2.1.2.2
        - Sampling and Analysis, D.2.1.2.3
      - Refractive Index Method, D.2.1.1
        - Equipment, D.2.1.1.1
        - Procedure, D.2.1.1.2
        - Sampling and Analysis, D.2.1.1.3
  - Inspection of Foam Concentrate, D.4
  - Interpretation of Foam Test Results, D.3
  - Procedures for Measuring Expansion and Drainage Rates of Foams, D.1
    - Foam 25 Percent Drainage Time Determination, D.1.8
    - Foam Chambers, D.1.5
    - Foam Sampling, D.1.1
    - Foam Testing, D.1.6
    - Overhead Devices, D.1.3
    - Pressure Foam, D.1.4
      - Procedure, D.1.7
      - Procedure, D.1.9
    - Turrets or Handline Nozzles, D.1.2

## Sequence of Events for the Standards Development Process

Once the current edition is published, a Standard is opened for Public Input.

### Step 1 – Input Stage

- Input accepted from the public or other committees for consideration to develop the First Draft
- Technical Committee holds First Draft Meeting to revise Standard (23 weeks); Technical Committee(s) with Correlating Committee (10 weeks)
- Technical Committee ballots on First Draft (12 weeks); Technical Committee(s) with Correlating Committee (11 weeks)
- Correlating Committee First Draft Meeting (9 weeks)
- Correlating Committee ballots on First Draft (5 weeks)
- First Draft Report posted on the document information page

### Step 2 – Comment Stage

- Public Comments accepted on First Draft (10 weeks) following posting of First Draft Report
- If Standard does not receive Public Comments and the Technical Committee chooses not to hold a Second Draft meeting, the Standard becomes a Consent Standard and is sent directly to the Standards Council for issuance (see Step 4) or
- Technical Committee holds Second Draft Meeting (21 weeks); Technical Committee(s) with Correlating Committee (7 weeks)
- Technical Committee ballots on Second Draft (11 weeks); Technical Committee(s) with Correlating Committee (10 weeks)
- Correlating Committee Second Draft Meeting (9 weeks)
- Correlating Committee ballots on Second Draft (8 weeks)
- Second Draft Report posted on the document information page

### Step 3 – NFPA Technical Meeting

- Notice of Intent to Make a Motion (NITMAM) accepted (5 weeks) following the posting of Second Draft Report
- NITMAMs are reviewed and valid motions are certified by the Motions Committee for presentation at the NFPA Technical Meeting
- NFPA membership meets each June at the NFPA Technical Meeting to act on Standards with “Certified Amending Motions” (certified NITMAMs)
- Committee(s) vote on any successful amendments to the Technical Committee Reports made by the NFPA membership at the NFPA Technical Meeting

### Step 4 – Council Appeals and Issuance of Standard

- Notification of intent to file an appeal to the Standards Council on Technical Meeting action must be filed within 20 days of the NFPA Technical Meeting
- Standards Council decides, based on all evidence, whether to issue the standard or to take other action

### Notes:

1. Time periods are approximate; refer to published schedules for actual dates.
2. Annual revision cycle documents with certified amending motions take approximately 101 weeks to complete.
3. Fall revision cycle documents receiving certified amending motions take approximately 141 weeks to complete.

## Committee Membership Classifications<sup>1,2,3,4</sup>

The following classifications apply to Committee members and represent their principal interest in the activity of the Committee.

1. M *Manufacturer*: A representative of a maker or marketer of a product, assembly, or system, or portion thereof, that is affected by the standard.
2. U *User*: A representative of an entity that is subject to the provisions of the standard or that voluntarily uses the standard.
3. IM *Installer/Maintainer*: A representative of an entity that is in the business of installing or maintaining a product, assembly, or system affected by the standard.
4. L *Labor*: A labor representative or employee concerned with safety in the workplace.
5. RT *Applied Research/Testing Laboratory*: A representative of an independent testing laboratory or independent applied research organization that promulgates and/or enforces standards.
6. E *Enforcing Authority*: A representative of an agency or an organization that promulgates and/or enforces standards.
7. I *Insurance*: A representative of an insurance company, broker, agent, bureau, or inspection agency.
8. C *Consumer*: A person who is or represents the ultimate purchaser of a product, system, or service affected by the standard, but who is not included in (2).
9. SE *Special Expert*: A person not representing (1) through (8) and who has special expertise in the scope of the standard or portion thereof.

NOTE 1: “Standard” connotes code, standard, recommended practice, or guide.

NOTE 2: A representative includes an employee.

NOTE 3: While these classifications will be used by the Standards Council to achieve a balance for Technical Committees, the Standards Council may determine that new classifications of member or unique interests need representation in order to foster the best possible Committee deliberations on any project. In this connection, the Standards Council may make such appointments as it deems appropriate in the public interest, such as the classification of “Utilities” in the National Electrical Code Committee.

NOTE 4: Representatives of subsidiaries of any group are generally considered to have the same classification as the parent organization.

## ***Submitting Public Input / Public Comment Through the Online Submission System***

Following publication of the current edition of an NFPA standard, the development of the next edition begins and the standard is open for Public Input.

### **Submit a Public Input**

NFPA accepts Public Input on documents through our online submission system at [www.nfpa.org](http://www.nfpa.org). To use the online submission system:








- Choose a document from the List of NFPA codes & standards or filter by Development Stage for “codes accepting public input.”
- Once you are on the document page, select the “Next Edition” tab.
- Choose the link “The next edition of this standard is now open for Public Input.” You will be asked to sign in or create a free online account with NFPA before using this system.
- Follow the online instructions to submit your Public Input (see [www.nfpa.org/publicinput](http://www.nfpa.org/publicinput) for detailed instructions).
- Once a Public Input is saved or submitted in the system, it can be located on the “My Profile” page by selecting the “My Public Inputs/Comments/NITMAMs” section.

### **Submit a Public Comment**

Once the First Draft Report becomes available there is a Public Comment period. Any objections or further related changes to the content of the First Draft must be submitted at the Comment Stage. To submit a Public Comment follow the same steps as previously explained for the submission of Public Input.

### **Other Resources Available on the Document Information Pages**

**Header:** View document title and scope, access to our codes and standards or NFCSS subscription, and sign up to receive email alerts.

 Current & Prior Editions	Research current and previous edition information.
 Next Edition	Follow the committee’s progress in the processing of a standard in its next revision cycle.
 Technical Committee	View current committee rosters or apply to a committee.
 Ask a Technical Question	For members, officials, and AHJs to submit standards questions to NFPA staff. Our Technical Questions Service provides a convenient way to receive timely and consistent technical assistance when you need to know more about NFPA standards relevant to your work.
 News	Provides links to available articles and research and statistical reports related to our standards.
 Purchase Products & Training	Discover and purchase the latest products and training.
 Related Products	View related publications, training, and other resources available for purchase.

## *Information on the NFPA Standards Development Process*

**I. Applicable Regulations.** The primary rules governing the processing of NFPA standards (codes, standards, recommended practices, and guides) are the *NFPA Regulations Governing the Development of NFPA Standards (Regs)*. Other applicable rules include *NFPA Bylaws*, *NFPA Technical Meeting Convention Rules*, *NFPA Guide for the Conduct of Participants in the NFPA Standards Development Process*, and the *NFPA Regulations Governing Petitions to the Board of Directors from Decisions of the Standards Council*. Most of these rules and regulations are contained in the *NFPA Standards Directory*. For copies of the *Directory*, contact Codes and Standards Administration at NFPA headquarters; all these documents are also available on the NFPA website at “[www.nfpa.org/regs](http://www.nfpa.org/regs).”

The following is general information on the NFPA process. All participants, however, should refer to the actual rules and regulations for a full understanding of this process and for the criteria that govern participation.

**II. Technical Committee Report.** The Technical Committee Report is defined as “the Report of the responsible Committee(s), in accordance with the Regulations, in preparation of a new or revised NFPA Standard.” The Technical Committee Report is in two parts and consists of the First Draft Report and the Second Draft Report. (See *Regs* at Section 1.4.)

**III. Step 1: First Draft Report.** The First Draft Report is defined as “Part one of the Technical Committee Report, which documents the Input Stage.” The First Draft Report consists of the First Draft, Public Input, Committee Input, Committee and Correlating Committee Statements, Correlating Notes, and Ballot Statements. (See *Regs* at 4.2.5.2 and Section 4.3.) Any objection to an action in the First Draft Report must be raised through the filing of an appropriate Comment for consideration in the Second Draft Report or the objection will be considered resolved. [See *Regs* at 4.3.1(b).]

**IV. Step 2: Second Draft Report.** The Second Draft Report is defined as “Part two of the Technical Committee Report, which documents the Comment Stage.” The Second Draft Report consists of the Second Draft, Public Comments with corresponding Committee Actions and Committee Statements, Correlating Notes and their respective Committee Statements, Committee Comments, Correlating Revisions, and Ballot Statements. (See *Regs* at 4.2.5.2 and Section 4.4.) The First Draft Report and the Second Draft Report together constitute the Technical Committee Report. Any outstanding objection following the Second Draft Report must be raised through an appropriate Amending Motion at the NFPA Technical Meeting or the objection will be considered resolved. [See *Regs* at 4.4.1(b).]

**V. Step 3a: Action at NFPA Technical Meeting.** Following the publication of the Second Draft Report, there is a period during which those wishing to make proper Amending Motions on the Technical Committee Reports must signal their intention by submitting a Notice of Intent to Make a Motion (NITMAM). (See *Regs* at 4.5.2.) Standards that receive notice of proper Amending Motions (Certified Amending Motions) will be presented for action at the annual June NFPA Technical Meeting. At the meeting, the NFPA membership can consider and act on these Certified Amending Motions as well as Follow-up Amending Motions, that is, motions that become necessary as a result of a previous successful Amending Motion. (See 4.5.3.2 through 4.5.3.6 and Table 1, Columns 1-3 of *Regs* for a summary of the available Amending Motions and who may make them.) Any outstanding objection following action at an NFPA Technical Meeting (and any further Technical Committee consideration following successful Amending Motions, see *Regs* at 4.5.3.7 through 4.6.5) must be raised through an appeal to the Standards Council or it will be considered to be resolved.

**VI. Step 3b: Documents Forwarded Directly to the Council.** Where no NITMAM is received and certified in accordance with the *Technical Meeting Convention Rules*, the standard is forwarded directly to the Standards Council for action on issuance. Objections are deemed to be resolved for these documents. (See *Regs* at 4.5.2.5.)

**VII. Step 4a: Council Appeals.** Anyone can appeal to the Standards Council concerning procedural or substantive matters related to the development, content, or issuance of any document of the NFPA or on matters within the purview of the authority of the Council, as established by the *Bylaws* and as determined by the Board of Directors. Such appeals must be in written form and filed with the Secretary of the Standards Council (see *Regs* at Section 1.6). Time constraints for filing an appeal must be in accordance with 1.6.2 of the *Regs*. Objections are deemed to be resolved if not pursued at this level.

**VIII. Step 4b: Document Issuance.** The Standards Council is the issuer of all documents (see Article 8 of *Bylaws*). The Council acts on the issuance of a document presented for action at an NFPA Technical Meeting within 75 days from the date of the recommendation from the NFPA Technical Meeting, unless this period is extended by the Council (see *Regs* at 4.7.2). For documents forwarded directly to the Standards Council, the Council acts on the issuance of the document at its next scheduled meeting, or at such other meeting as the Council may determine (see *Regs* at 4.5.2.5 and 4.7.4).

**IX. Petitions to the Board of Directors.** The Standards Council has been delegated the responsibility for the administration of the codes and standards development process and the issuance of documents. However, where extraordinary circumstances requiring the intervention of the Board of Directors exist, the Board of Directors may take any action necessary to fulfill its obligations to preserve the integrity of the codes and standards development process and to protect the interests of the NFPA. The rules for petitioning the Board of Directors can be found in the *Regulations Governing Petitions to the Board of Directors from Decisions of the Standards Council* and in Section 1.7 of the *Regs*.

**X. For More Information.** The program for the NFPA Technical Meeting (as well as the NFPA website as information becomes available) should be consulted for the date on which each report scheduled for consideration at the meeting will be presented. To view the First Draft Report and Second Draft Report as well as information on NFPA rules and for up-to-date information on schedules and deadlines for processing NFPA documents, check the NFPA website ([www.nfpa.org/docinfo](http://www.nfpa.org/docinfo)) or contact NFPA Codes & Standards Administration at (617) 984-7246.



# THE TRAINING YOU NEED. THE SAFETY YOU REQUIRE.

## **ONLINE AND VIRTUAL CLASSROOM COURSES FROM THE CONVENIENCE OF YOUR COMPUTER.**

NFPA® is dedicated to meeting your professional development needs. We provide a variety of solutions to ensure you or your team has access to top-quality, in-depth, virtual instruction and continuing education units (CEUs).

## **LEARN AT YOUR OWN PACE VIA OUR ONLINE TRAINING COURSES.**

Complete the training when and where you choose from your laptop or PC. Choose from an array of engaging and high-impact online training programs for individual students or groups.

## **REGISTER FOR OUR NEWLY LAUNCHED LIVE VIRTUAL TRAINING CLASSES.**

NFPA is now offering expert instructor-led safety training online. Attend classes in real time over the Internet for immersive, interactive learning that mirrors the experience of being there in person. Courses are limited in size and specially designed to engage students online.

➤ Learn more about NFPA online and live virtual training, and discover which courses are right for you at [nfpa.org/livevirtualtraining](https://www.nfpa.org/livevirtualtraining).

➤ To learn how your team can benefit from NFPA training, call the NFPA sales team at **877-336-3280** or email us at [grouptraining@nfpa.org](mailto:grouptraining@nfpa.org).



**IMEN SAZEH VAZIN**  
Design and implementation of fire extinguishing system

# ایمن سازه وزین

مشاوره، طراحی، تامین و اجرا سیستم‌های اعلام و اطفاء حریق



اجرا خطوط لوله ( Piping ) فرایندی صنعتی



سرویس و نگهداری سیستم‌های اعلام و اطفاء حریق



تولید تجهیزات و تجهیز خودرو آتش نشانی و امدادی



تامین نیرو و راهبری ایستگاه‌های آتش‌نشانی

